

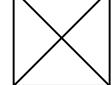
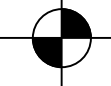
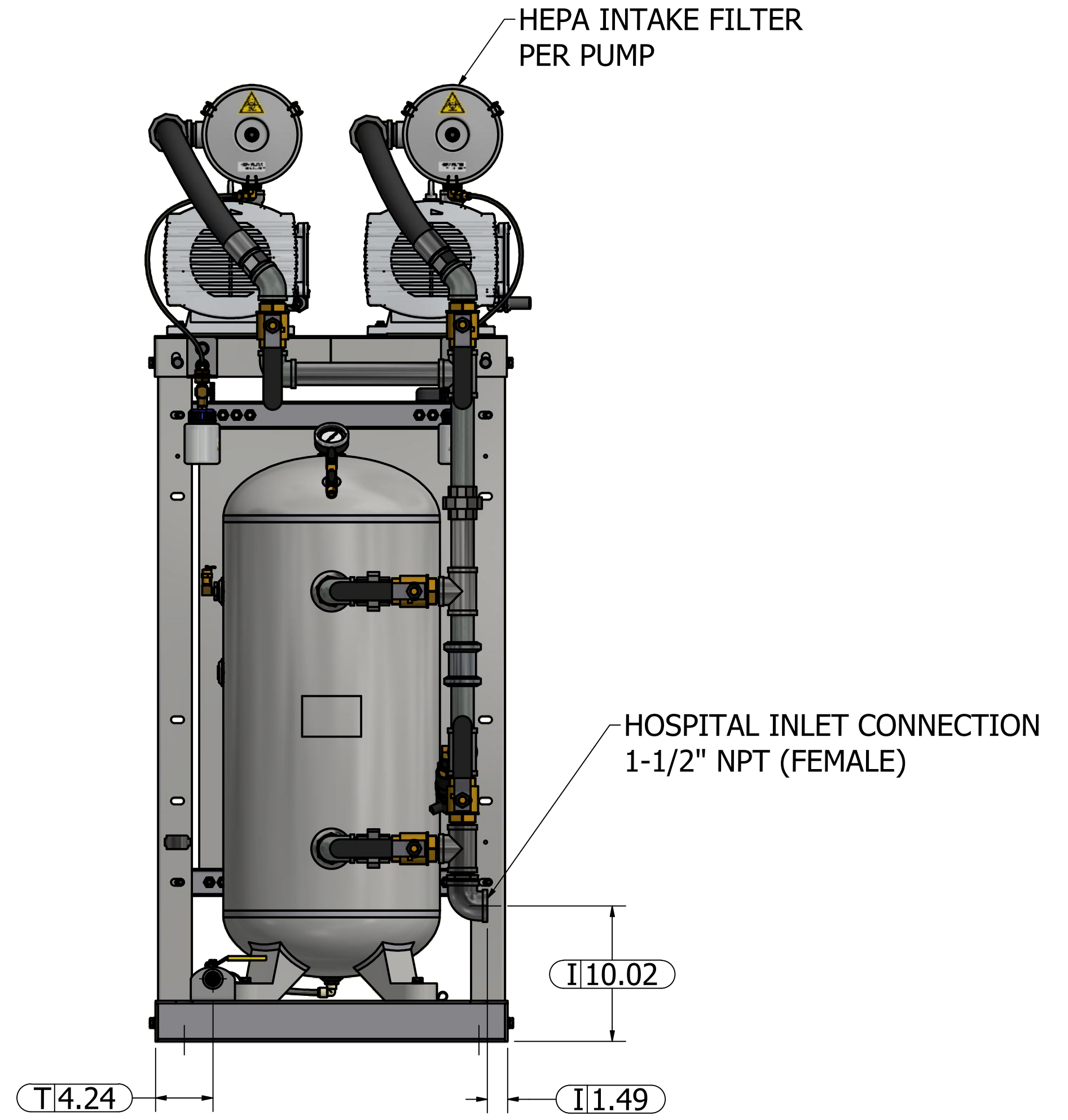
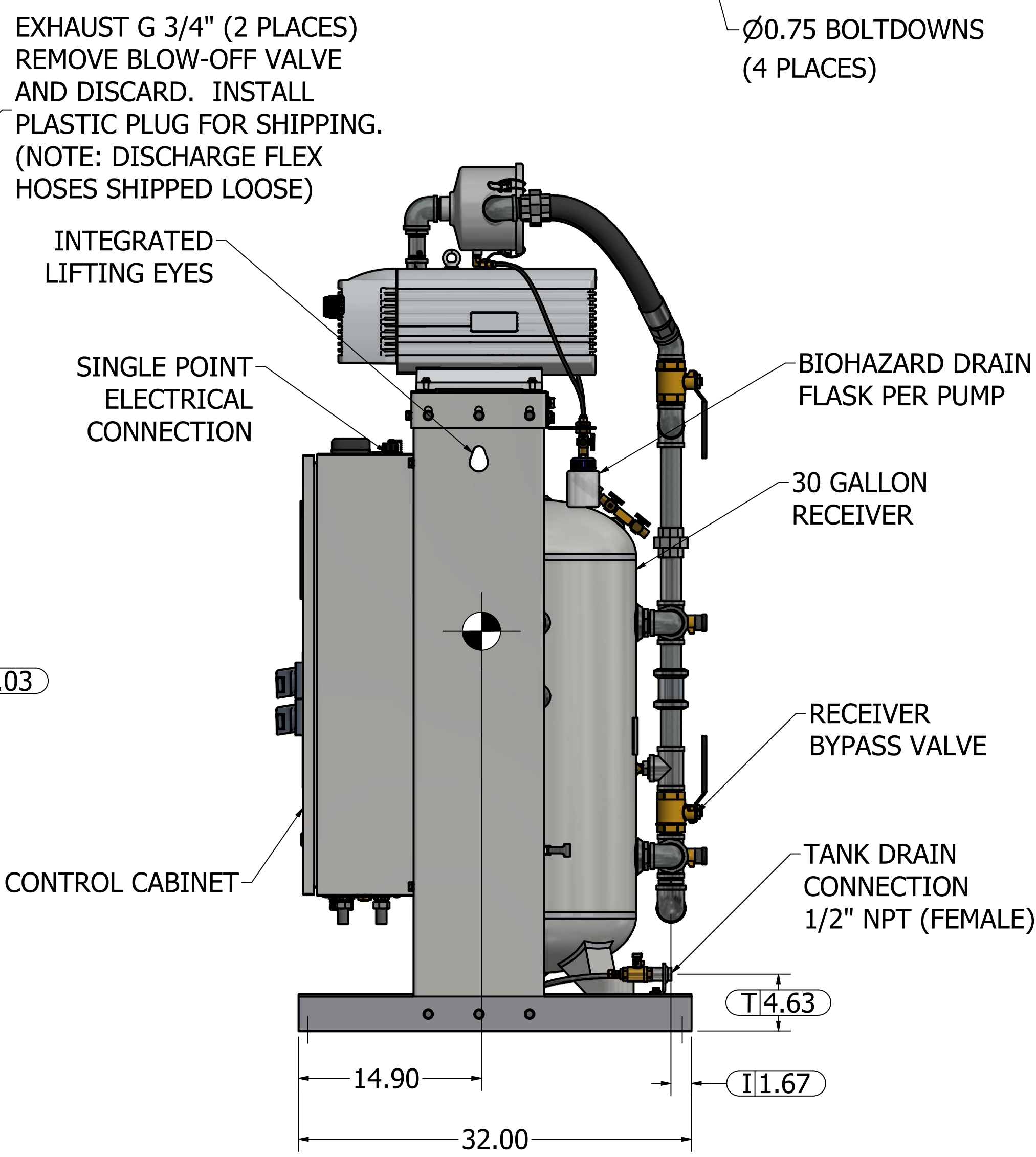
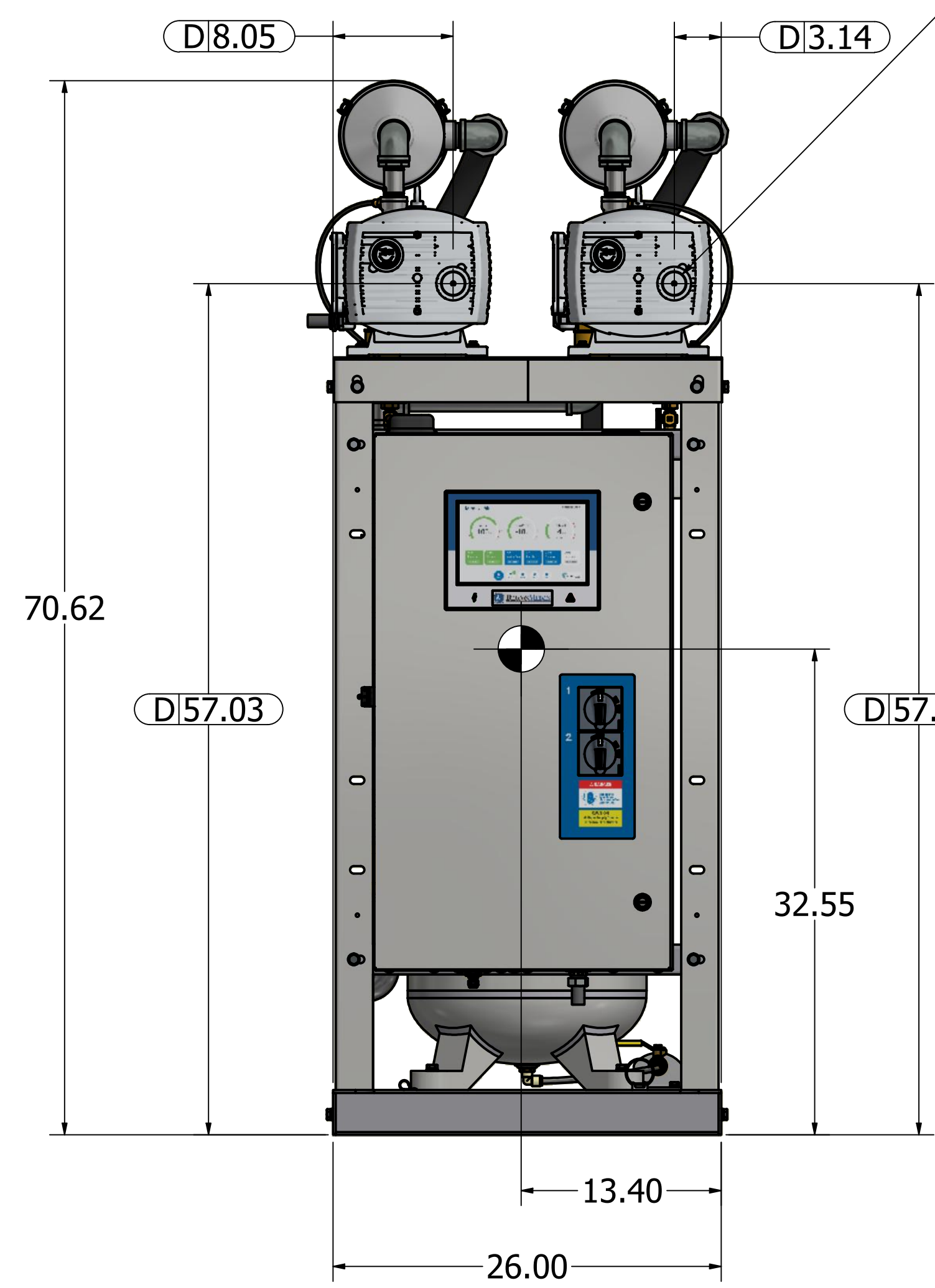
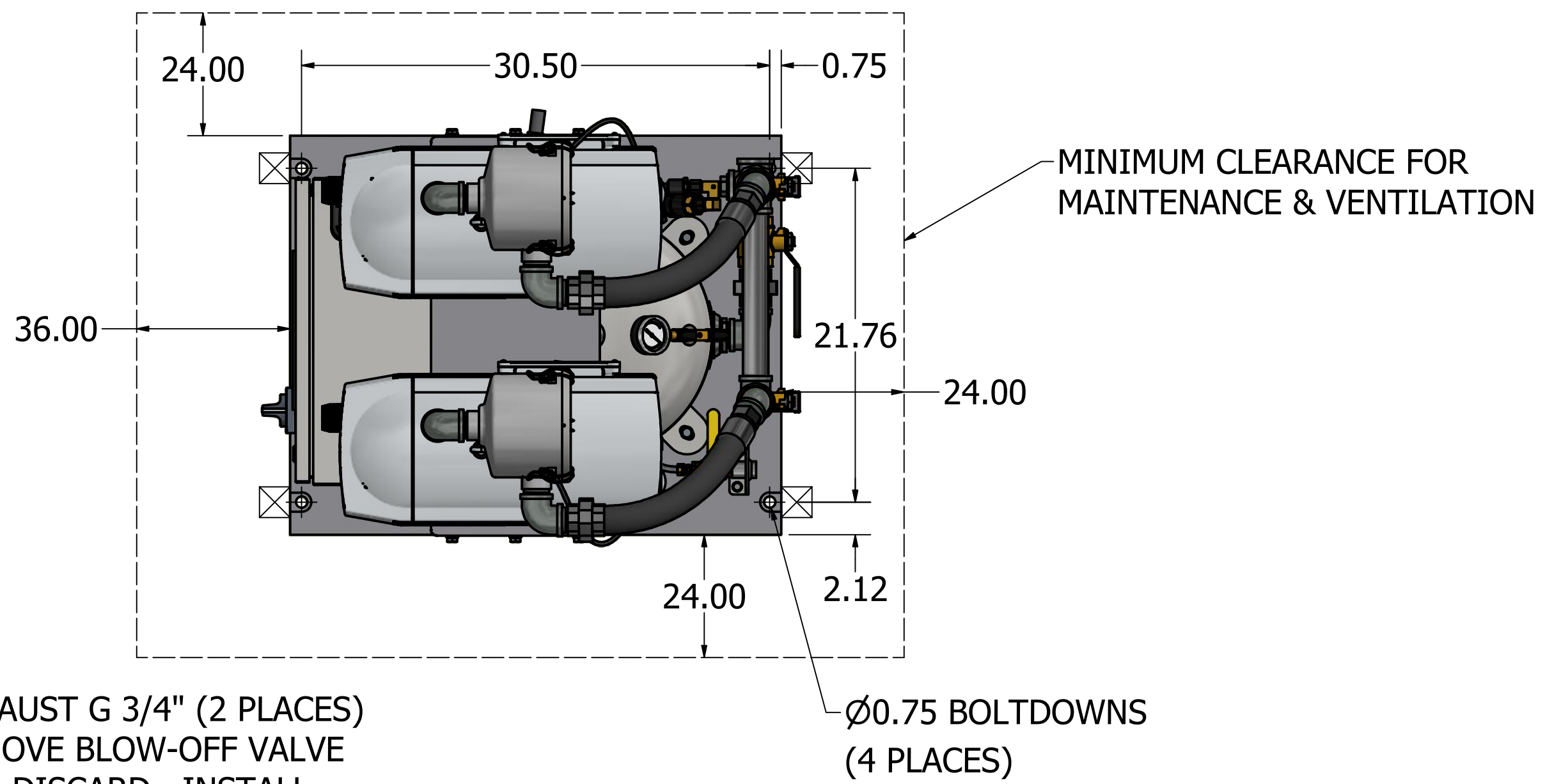

This drawing and the information contained thereon remain the property of BeaconMedaes and may not be used for other than the purpose for which it is loaned without the expressed written permission from BeaconMedaes Engineering.

Notes:

1. SYSTEM WEIGHT: 556 LBS
2.  INDICATES LIFTING POINTS
3.  DENOTES CENTER OF GRAVITY

SYSTEM CONNECTIONS	
ID	DESCRIPTION
I	INLET LOCATION
D	DISCHARGE LOCATION
T	TANK DRAIN



Revised: APS	Date: 2/27/2023	Drawn: BKW	Date: 8/5/2022
		This drawing and the information contained thereon remain the property of BeaconMedaes and may not be used for other than the purpose for which it is loaned without the expressed written permission from BeaconMedaes Engineering.	
Description: DWG GA DX 2HP DRY VTM V 30G TAE BECKER		Part Number: 4107 8579 82	Scale: D
DN: HOP230844		Rev: 01	DO NOT SCALE THIS DOCUMENT
Sheet 1 of 1			