

This drawing and the information contained thereon remain the property of BeaconMedaes and may not be used for other than the purpose for which it is loaned without the expressed written permission from BeaconMedaes Engineering.

Notes:

1. SYSTEM WEIGHT: 516 LBS
2.  INDICATES LIFTING POINTS
3.  DENOTES CENTER OF GRAVITY

SYSTEM CONNECTIONS	
ID	DESCRIPTION
I	INLET LOCATION
D	DISCHARGE LOCATION
T	TANK DRAIN

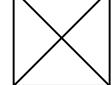
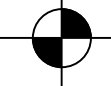
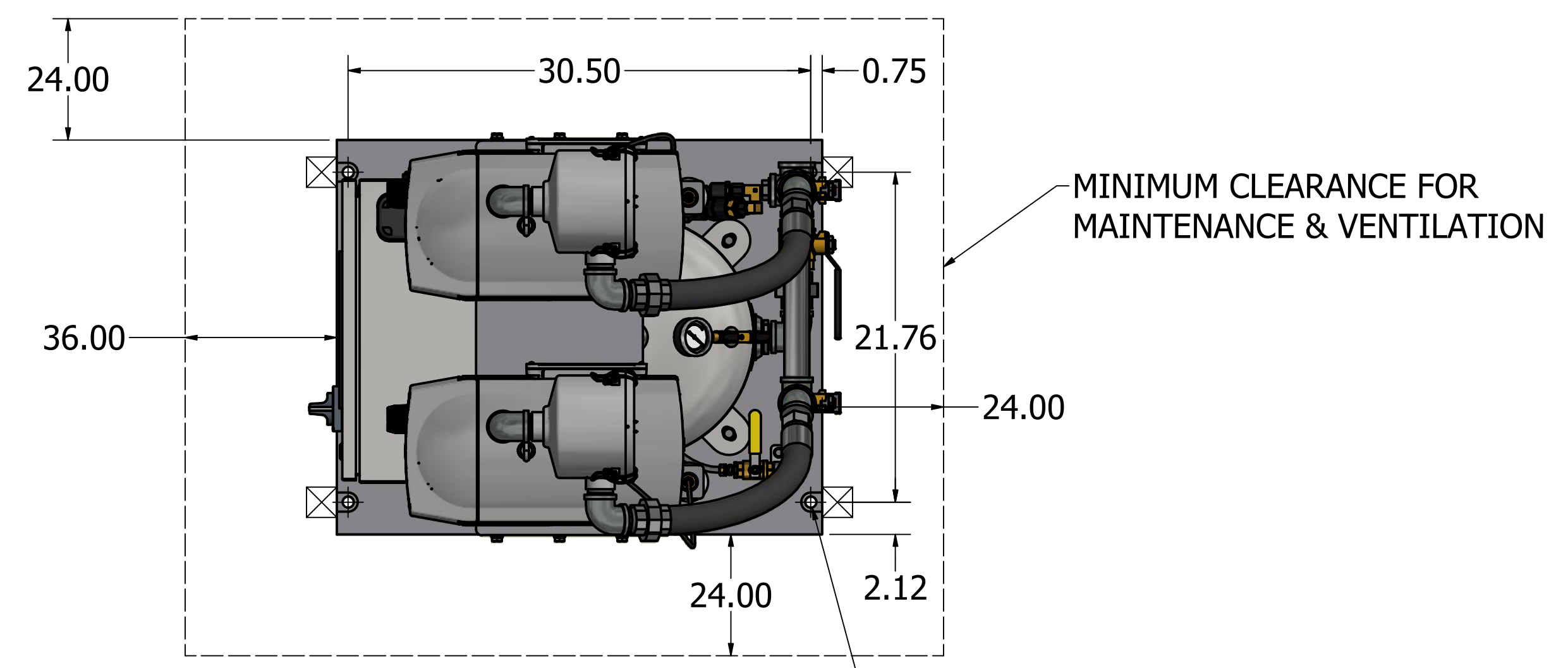

EXHAUST
G 3/4" (2 PLACES)
REMOVE BLOW-OFF VALVE
AND DISCARD. INSTALL
PLASTIC PLUG FOR SHIPPING.
(NOTE: DISCHARGE FLEX
HOSES SHIPPED LOOSE)

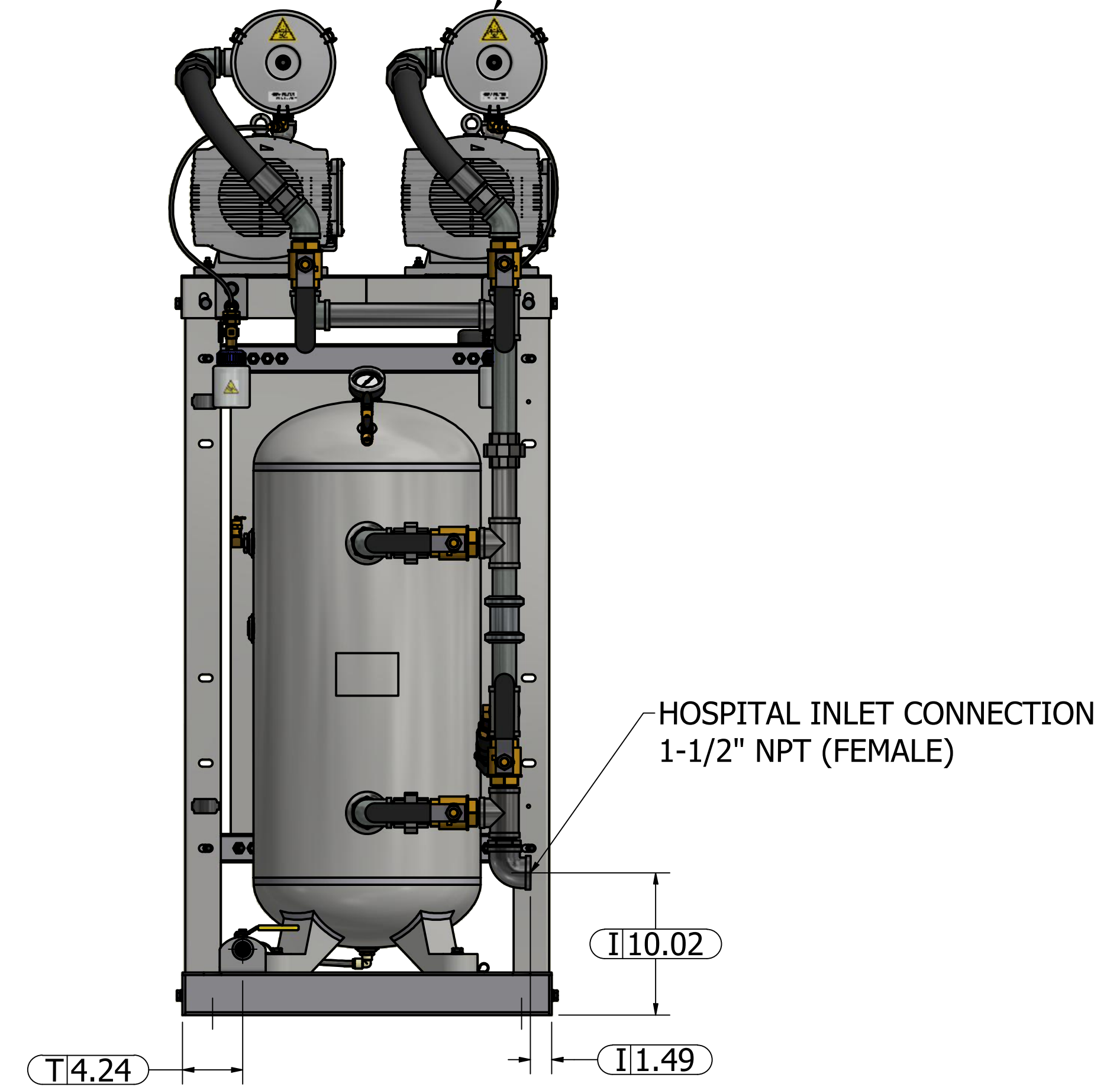
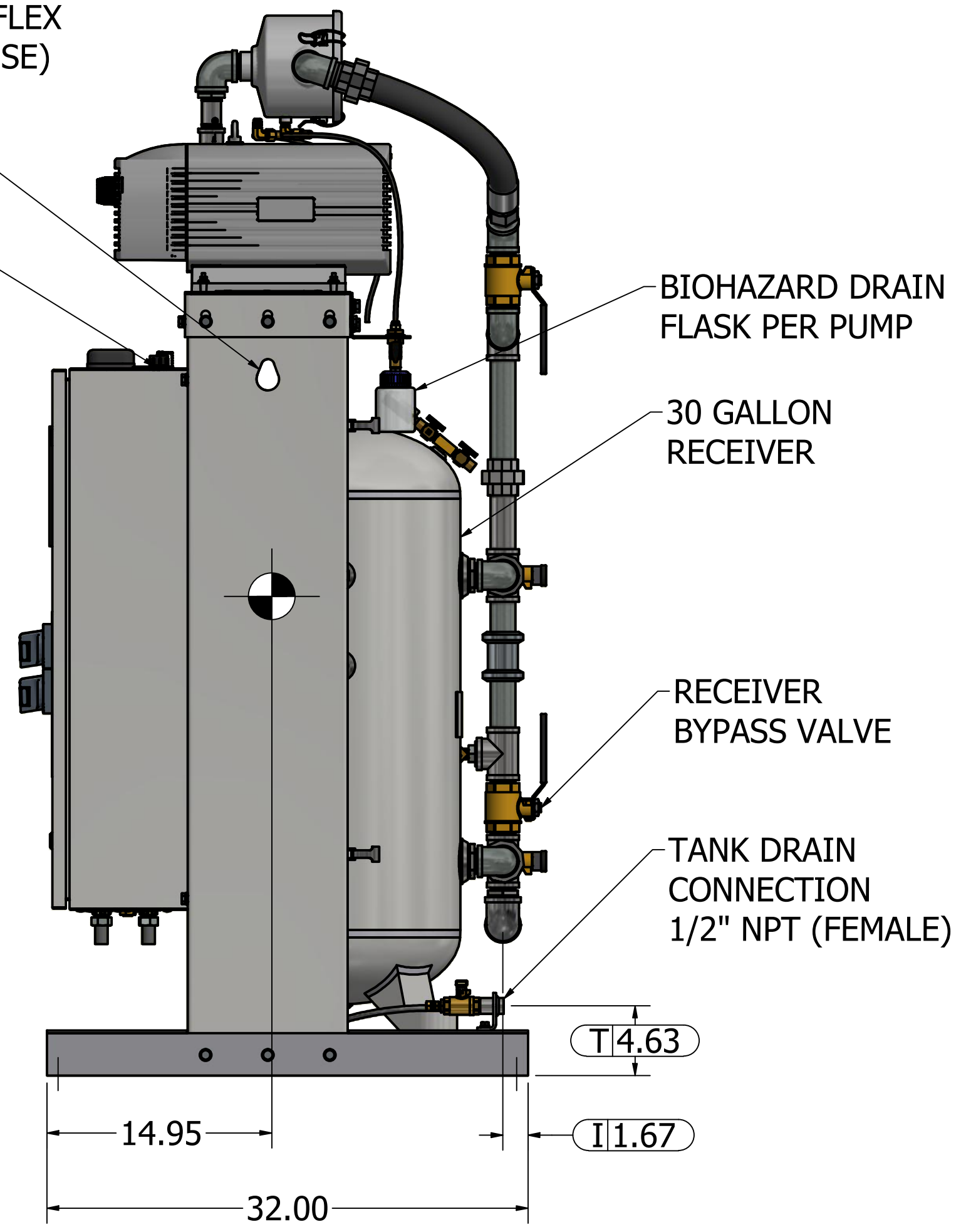
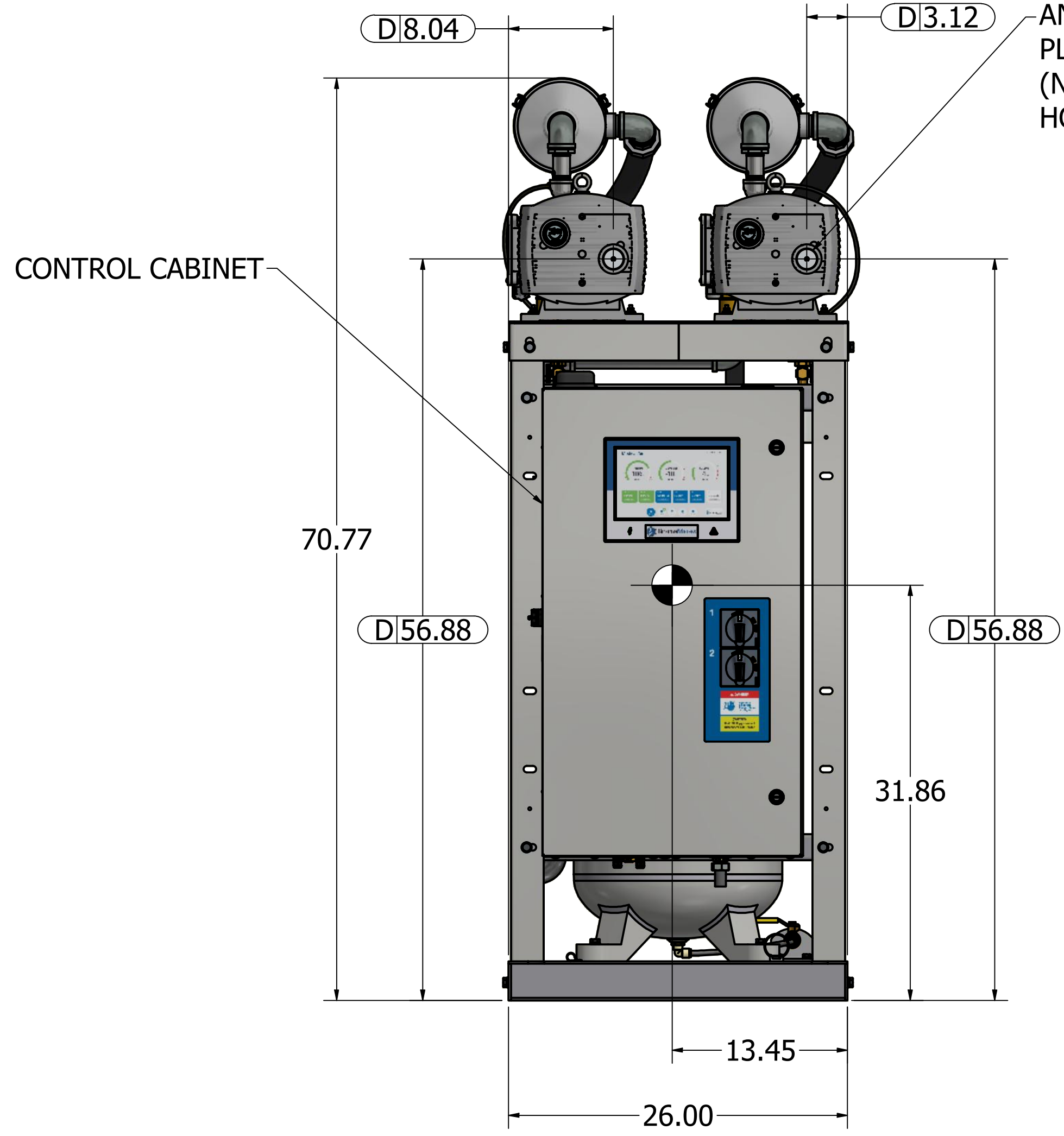

Revised: APS	Date: 2/28/2023	Drawn: BKW	Date: 8/5/2022
 This drawing and the information contained thereon remain the property of BeaconMedaes and may not be used for other than the purpose for which it is loaned without the expressed written permission from BeaconMedaes Engineering.		Scale: D	
Description: DWG GA DX 1.2HP DRY VTM V 30G DN: TAE BECKER		Part Number: 4107 8579 81	
Sheet 1 of 1		Rev: 01	