

This drawing and the information contained thereon remain the property of BeaconMedaes and may not be used for other than the purpose for which it is loaned without the expressed written permission from BeaconMedaes Engineering.

- Notes:**
1. SYSTEM WEIGHT: 378 LBS
 2.  INDICATES LIFTING POINTS
 3.  DENOTES CENTER OF GRAVITY

SYSTEM CONNECTIONS	
ID	DESCRIPTION
I	INLET LOCATION
D	DISCHARGE LOCATION
T	TANK DRAIN

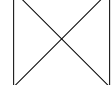
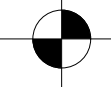
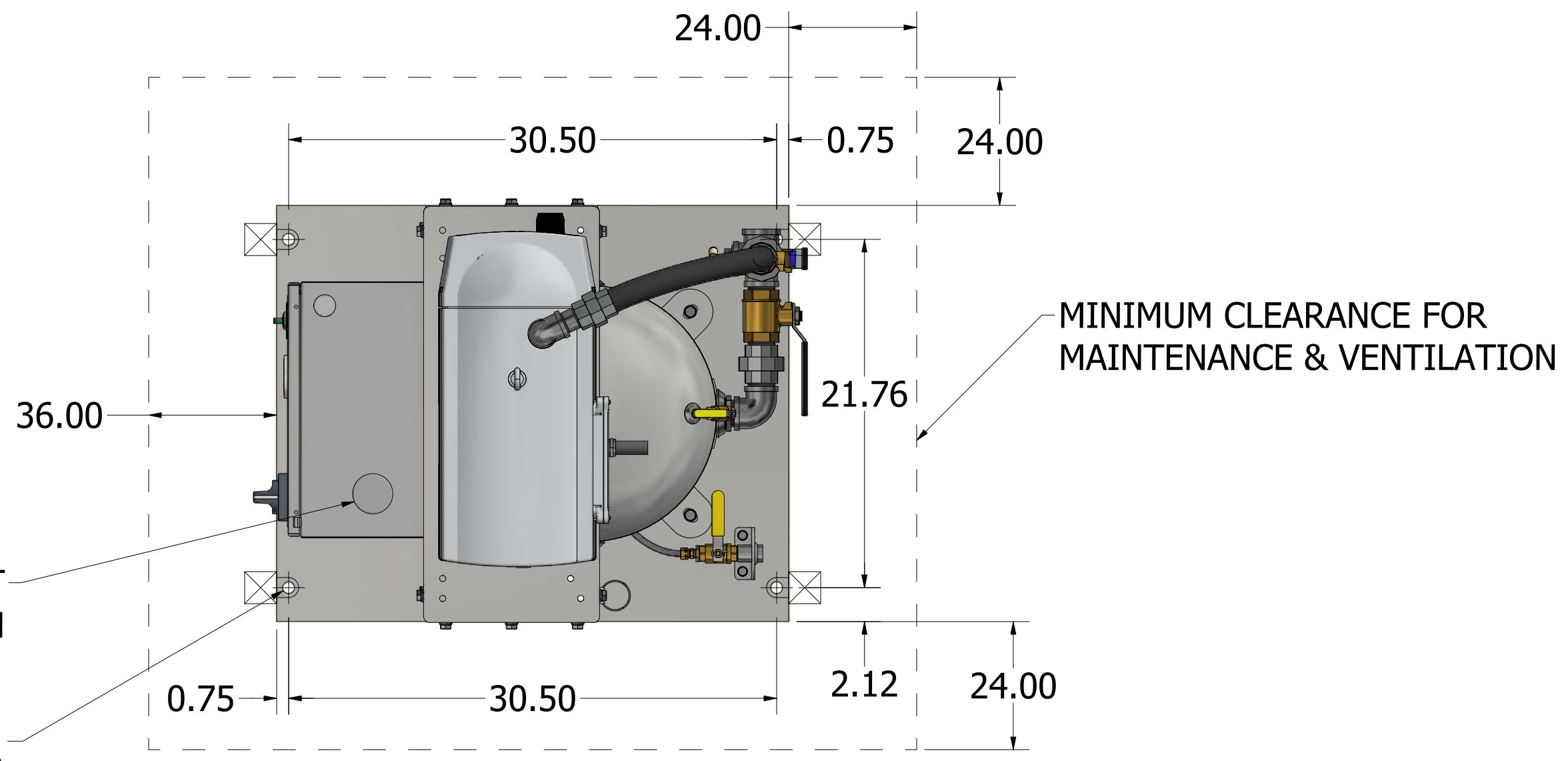

EXHAUST G 3/4" REMOVE BLOW-OFF VALVE AND DISCARD. INSTALL PLASTIC PLUG FOR SHIPPING. (NOTE: DISCHARGE FLEX HOSE SHIPPED LOOSE)

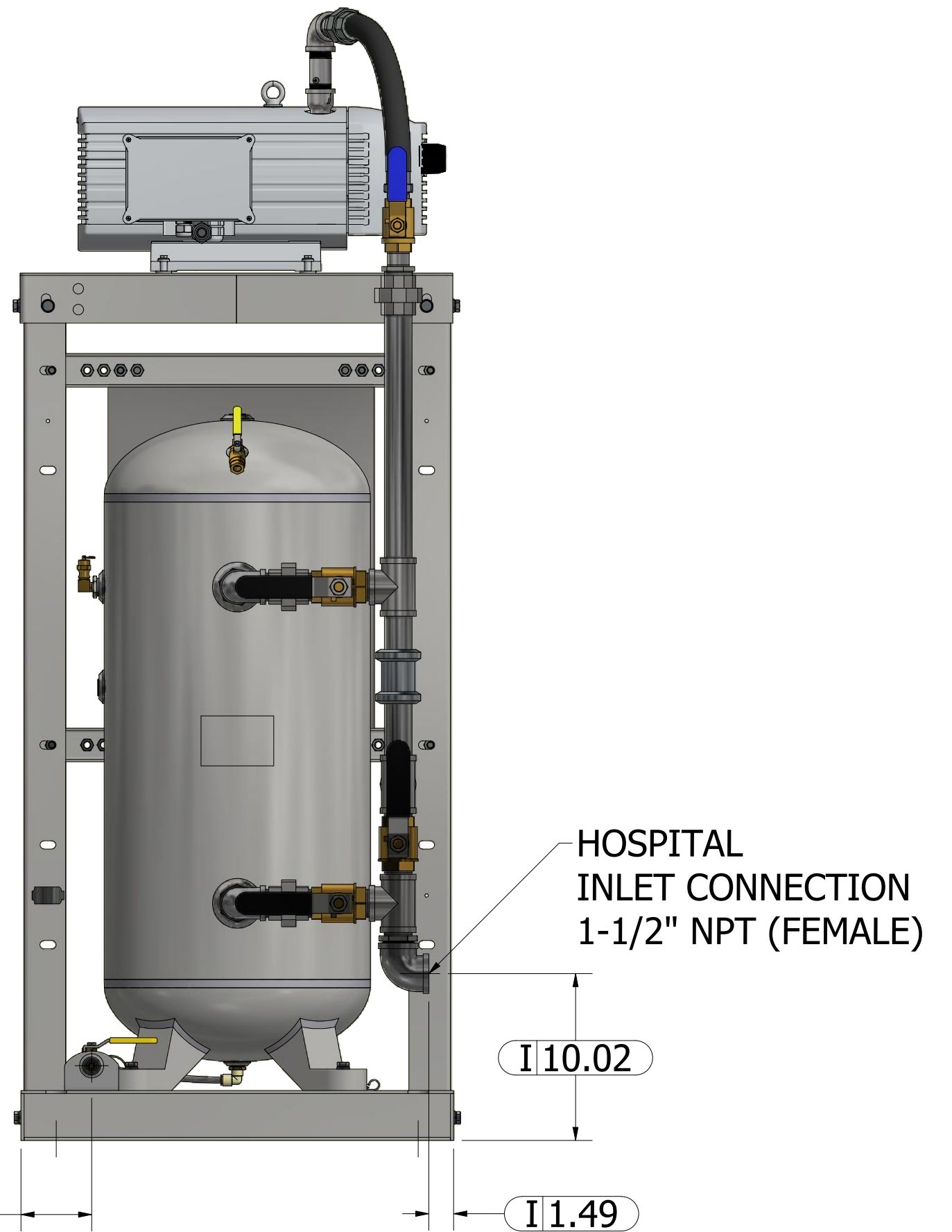
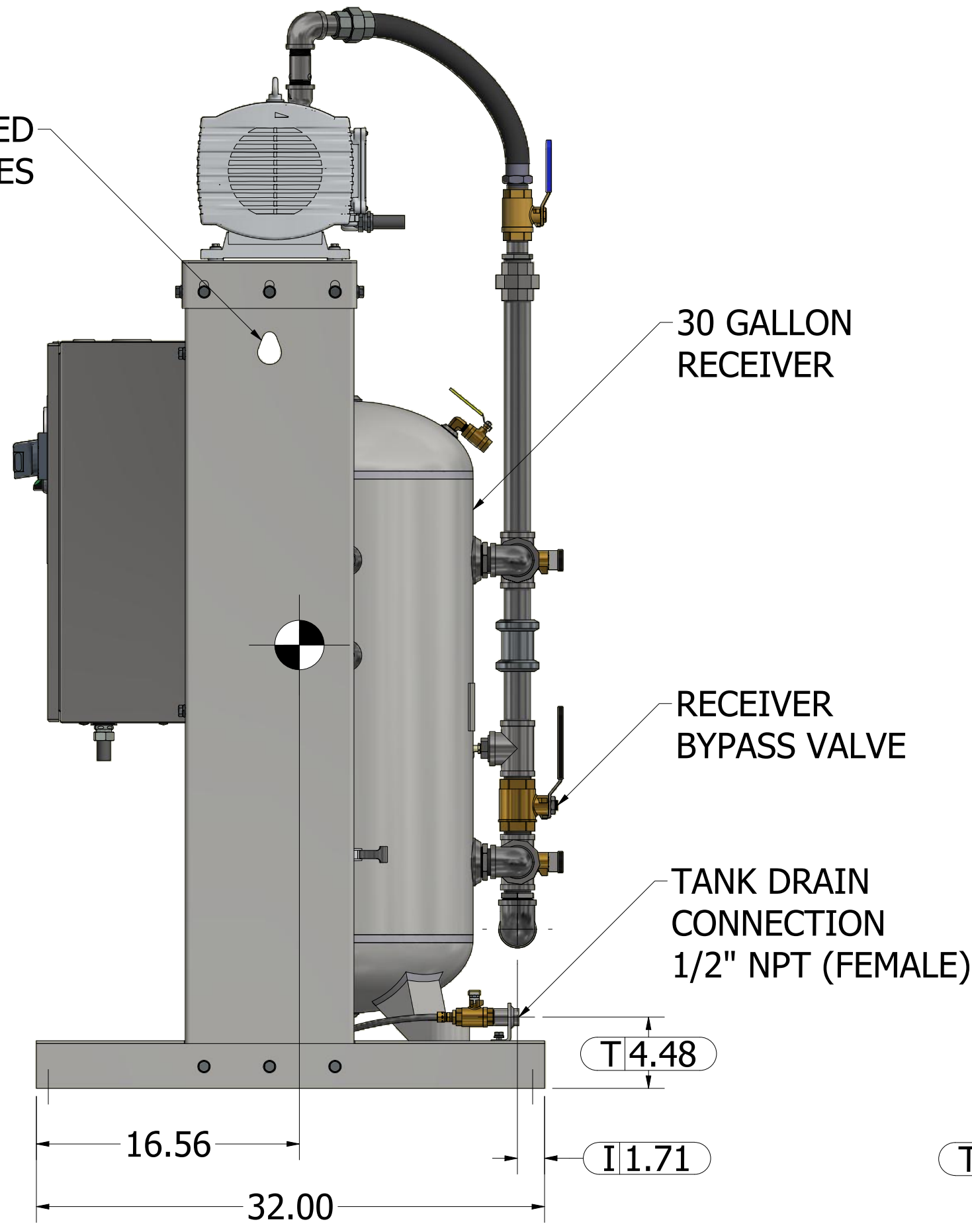
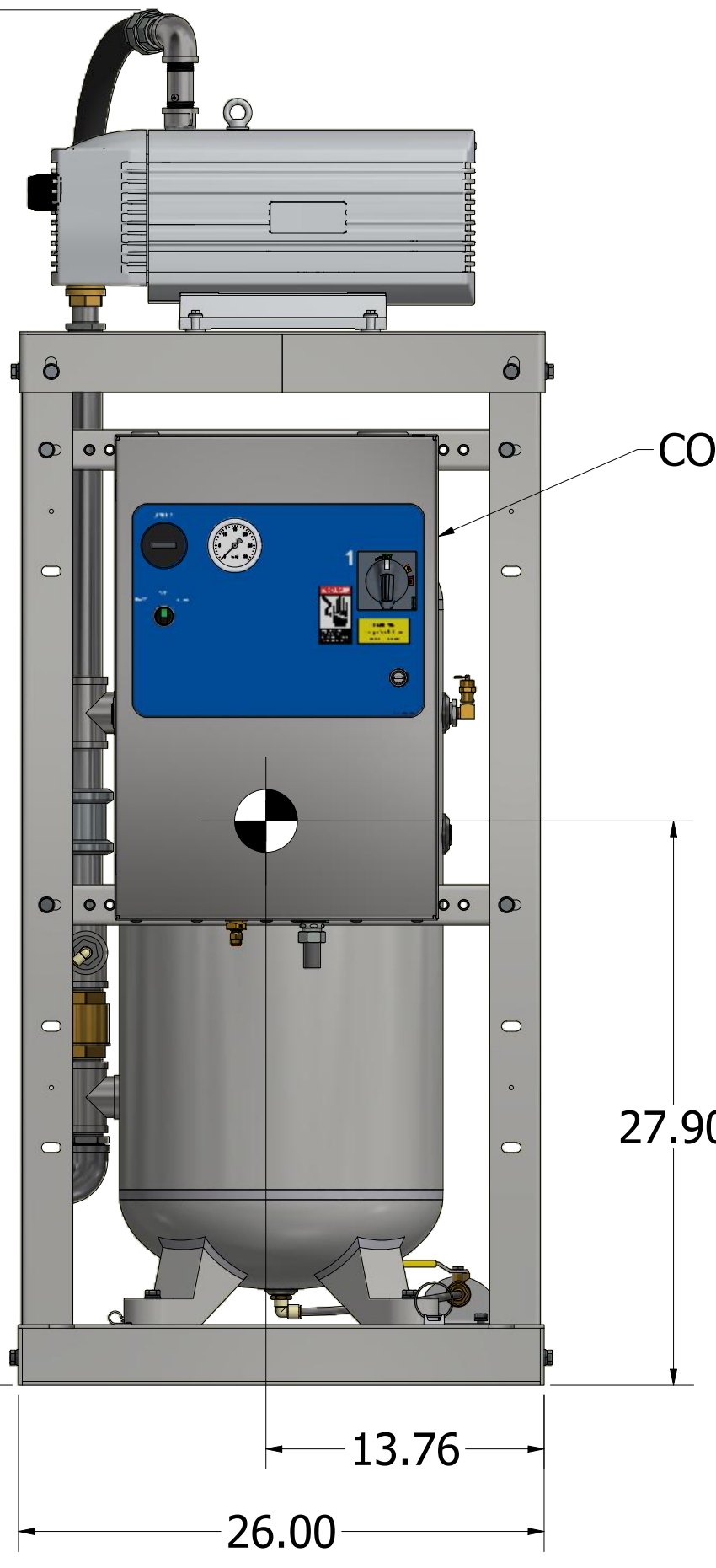
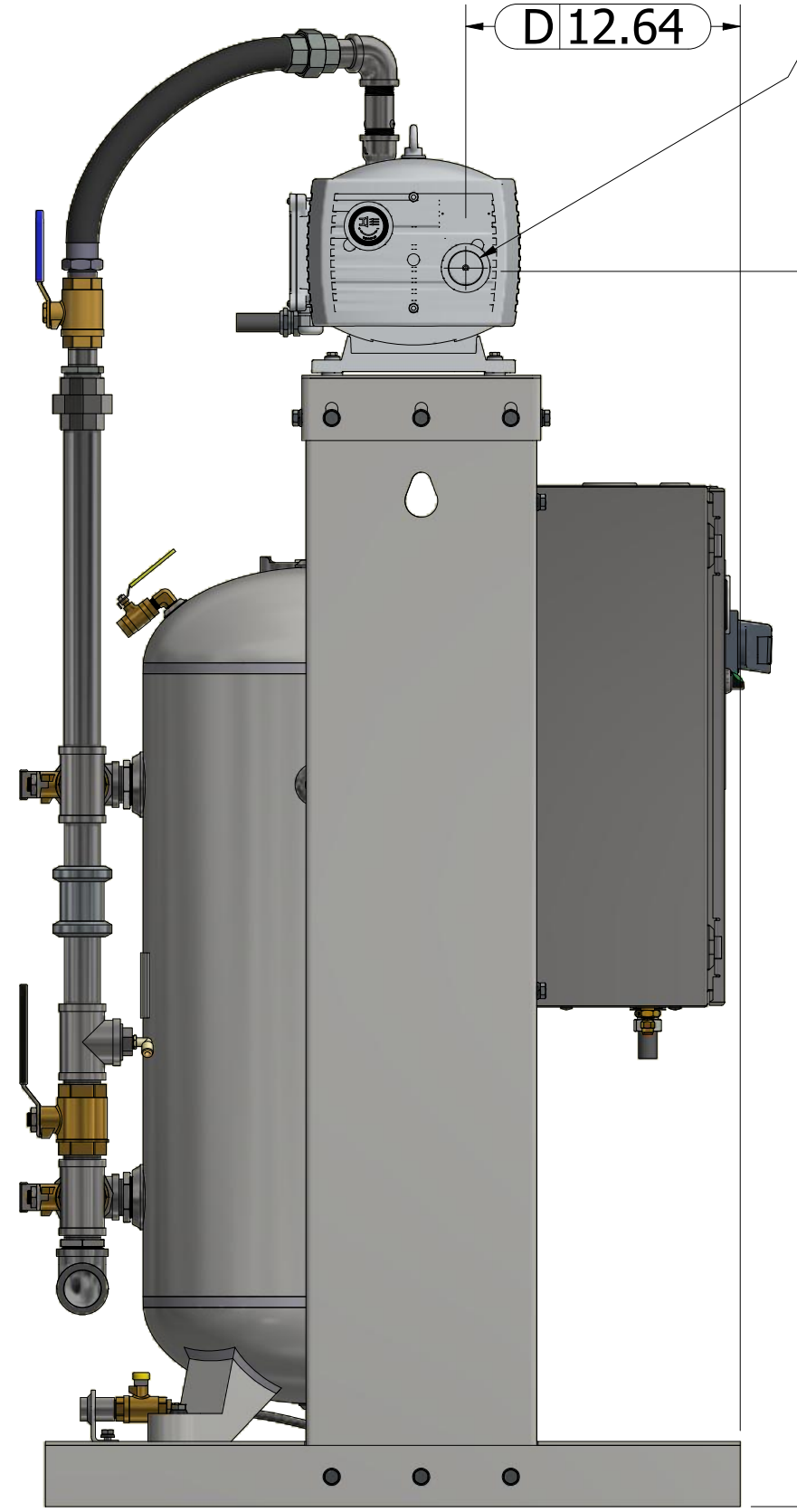

Revised:	Date:	Drawn:	Date:
		BKW	7/28/2022
		This drawing and the information contained thereon remain the property of BeaconMedaes and may not be used for other than the purpose for which it is loaned without the expressed written permission from BeaconMedaes Engineering.	
Description:		Part Number:	
DWG GA SX 2HP DRY VTM V 30G BASIC BECKER		4107 8579 78	
DN:	HOP220451	Rev:	00
Sheet	1 of 1	DO NOT SCALE THIS DOCUMENT	