

PNEUMATECH MGS

Dual medical air purifiers

Pure protection
Pure partnership
Pure reliability



Medical Air Plant – Surgical Air Plant – Combined Air Plant
HTM2022 & HTM02-01

CE
2460

 **pneumatech**
medical gas solutions

Pneumatech Medical Gas Solutions

Medical Air Plant – Surgical Air Plant – Combined Air Plant
HTM2022 & HTM02-01

Instruction book

Original instructions

Copyright notice

Any unauthorized use or copying of the contents or any part thereof is prohibited.

This applies in particular to trademarks, model denominations, part numbers and drawings.

This instruction book is valid for CE as well as non-CE labelled machines. It meets the requirements for instructions specified by the applicable European directives as identified in the Declaration of Conformity.

2021 - 03

No. 4233 5000 24 – 02

www.p-mgs.com

Table of contents

1	Safety precautions.	5
2	Nomenclature	5
3	General description.....	6
4	Installation	8
5	Commissioning.	11
6	Medical device directive.	14

1 Safety precautions

1.1 Safety icons

Explanation

The applicable safety precautions can be found in the respective Instruction book:

Instruction book	Compressor type
2920709781	GA 5-11 MED AIB
9828093012	GA 15-26 MED AIB
2920710923	GA 7-15 VSD+ AIB
2920711002	GA 18-37 VSD+ AIB
2932292030	GA VSD+ MED Addendum

Instruction book	Medical Air Purifier
4233500011	PureMED AIB

2 Nomenclature

Each model within the range is identified by a unique sequence of letters and number for example (except specials):

mAIR-2470-TGF4 HTM02-01 50Hz

<p>Plant Type:</p> <ul style="list-style-type: none"> MEDAIR: Medical Air <p>Compressor element technology:</p> <ul style="list-style-type: none"> G: GA-MED (Oil injected screw compressor) S: SF-MED (Oil free scroll compressor) Z: ZT-MED (Oil free tooth compressor) A: AQ-MED (Water injected screw compressor) <p>Number of compressors:</p> <ul style="list-style-type: none"> S: Simplex D: Duplex T: Triplex Q: Quadruplex P: Pentaplex H: Hexaplex <p>Design flow:</p> <ul style="list-style-type: none"> 2470: 2470 l/min after dryer purge losses 	<p>Supply pressure:</p> <ul style="list-style-type: none"> 4: 4 bar 7: 7 Bar 10: 10 bar <p>Design flow:</p> <ul style="list-style-type: none"> 2470: 2470 l/min after dryer purge losses <p>Standard:</p> <ul style="list-style-type: none"> HTM2022 HTM02-01 <p>Electrical frequency for motors</p> <ul style="list-style-type: none"> 50Hz 60Hz
--	---

3 General description

3.1 Introduction

Description

The Medical Air Plant, Surgical Air Plant and Combined Air plant range is specifically designed and manufactured to fully satisfy the requirements of the United Kingdom National Health Service – Model Engineering specification C11, Health Technical Memorandum (HTM 2022 and HTM02-01).

Medical Air Plant and Combined Air plant utilize (either duplex, triplex or quadruplex) compressors, (either single, duplex or triplex) air receivers, and heatless dryers.

Surgical Air Plant utilize compressors, (either single or duplex) air receivers (either single or duplex) and heatless dryers.

Each plant is subject to comprehensive QA controls during manufacture, incorporates components with proven reliability and critical parts are tested prior to dispatch.

The Plant has been specifically designed for ease of installation. It is designed as a modular system and is supplied as principle components, enabling a degree of flexibility in the installation layout. A comprehensive plant range is available to satisfy hospital design.

The Medical Air Plant or Combined Air plant basically consists of following components:

- Duplex, triplex, or quadruplex identical air compressors (depending on model).
- A single or duplex air receiver (depending on model)
- Duplex filter dryer assemblies
- A central controller, controlling compressors and dryer (PureLogic)
- A local controller for each air compressor

The Surgical Air Plant consists of following components:

- Air compressors (depending on model).
- A single or duplex air receiver. (Depending on model)
- Duplex filter dryer assemblies
- A central controller, controlling compressors and dryer (PureLogic)
- A local controller for each air compressor

A Combined Medical and Surgical air plant provides a single connection point at 11 bar or 7 bar pressure for connecting to the surgical air pipeline system. A tee'd connection from the surgical air pipeline is connected to a duplex pressure reducing set (available separately) and is installed within the plant room in order to provide a 4 bar line pressure connection suitable for the medical air pipeline system. The design flow is the sum of the medical air and surgical air requirement.

The installation is designed and valved to provide a Lead and Standby for all major components and enables the compressor, filter/dryer, regulator and/or the air receiver(s) to be isolated with the plant remaining operational. A simplified schematic is detailed in below image:

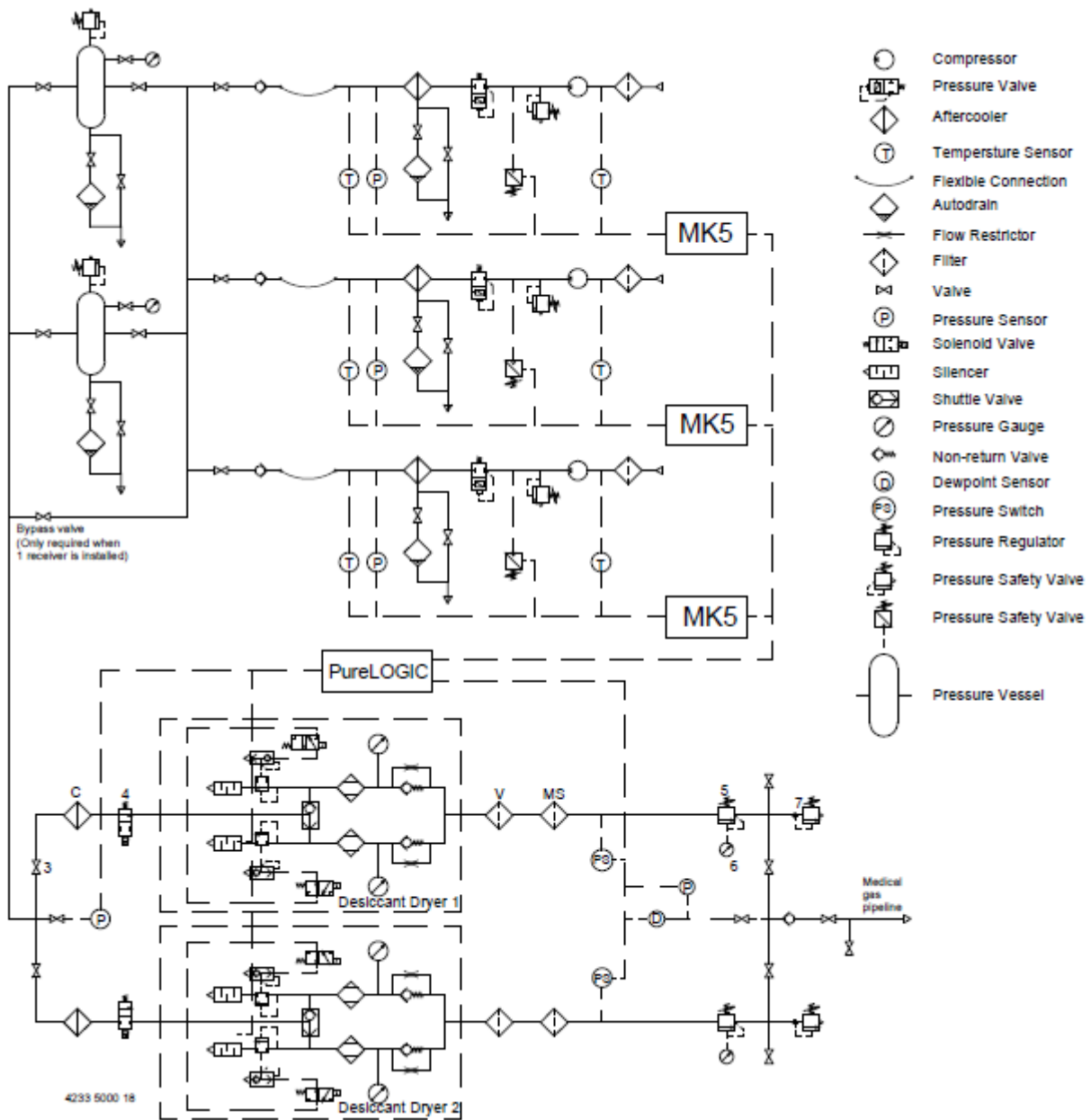

Air Plant Performance

In accordance with C11, as revised in April 1993, the Plant provides a minimum of the Average Continuous Demand (ACD) corrected to NPT with one compressor stationary. This applies to all units. The plant also produces a minimum of 5 cubic metres/kWh, at a continuous Plant Flow Rate of 100% and at 10% of the ACD over a period.

4 Installation

Introduction

Installation of an Air Plant must be carried out by suitably qualified and competent personnel who fully understand the standards required when working on a piped medical gas distribution system and are conversant with the information contained in this instruction book and the instruction books of the separate components. Installation must be carried out strictly in accordance with the specific installation proposal and service diagram issued with the plant.

The Air Plant must be installed within a plant room which provides adequate ventilation for the cooling of electric motors, bearing in mind that approximately 75% of all energy consumed is dissipated into the plant room as heat energy. At least 500 mm must be allowed between the plant and any walls or other obstructions and additional headroom is required to enable installation. Specific plant dimensions must be taken in to account especially where access is limited. Install the units in an area where the noise levels do not cause an inconvenience.

The intake of the air of the plant for the compressors should be taken from sources free of possible contamination such as combustion engines exhausts, chimneys, garbage belts or containers, loading/unloading docks of trucks, areas where trucks or cars frequently stand still, air conditioning or refrigerating equipment using HCFC (chlorinated hydrocarbons, freon, ...), air conditioning air outlet or e.g. surgery room air extraction equipment, etc.

Mechanical Installation

See the applicable plant part installation document for respective details:

Installation document	Compressor type
9828496906	GA 5-11 MED
9828083038	GA 15-26 MED
9820695001	GA 7-15 VSD+
9820720171	GA 18-37 VSD+

Installation document	Medical air purifier
2212021742	PureMED

1. Please take into account the recommendations as explained in the instruction books of the components, e.g. regarding removing of transport protections, placement and ventilation ducting
2. Remove any transportation protection caps from pipes. Check that no ingress has occurred, if necessary clean the pipes.
3. Mount each connection kit, supplied in a box with every compressor, to the compressor outlet pipe.
4. Mount the vessel connection kits, supplied in a separate box, to each vessel.
5. Connect piping between the units according to the installation proposal. Clean the piping network before brazing. Connect the distribution pipeline installation to the dryer outlet. All pipes must be secured to give added stability. Typical pipe connections as below image:



Electrical connections

Power supply

Consult the service diagrams (inside the cubicles) and verify the motor data plates. Ensure that the power supply is off and correctly isolated before connecting to the cubicles. All wiring must be in accordance with IEE regulations. Cable sizes and fuses given in the respective chapters of the compressor and dryer instruction books are recommendations, all cable sizes and protective devices must be sized by a qualified electrician.

The Air Plant requires a separate power supply for each compressor, preferably from an essential circuit, and requires a 210-230 V AC (or 115V AC) supply to the central controller cubicle (PureLogic).

Check that the central controller power LED is lit, and the controller screen is operational when the supply voltage is connected.

Earth the vessels and other piping as required.

CAN network

Take the CAN network cable from the box supplied with every compressor. Verify that the lengths (10 m) are sufficient to connect each unit. If not, longer cable length and separate connectors can be ordered (see Spare parts list GA-MED). Route the cables properly and attach each cable as follows:

1. Connect the CAN cable from the dryer controller to the top connection of the first compressor (closest to the dryer).
2. Connect the CAN cable from the 1st compressor's bottom socket to the next compressors top socket. Fit the label number '1' to compressor 1. Repeat until the last compressor, fitting the associated compressor label number.

- Open the controls cabinet on the compressor unit of the last Compressor from point 2. Change the End of line CAN switch to [ON].



Pre start checks

1	Ensure that all electrical power supplies to the plant are off and isolated at the controllers (isolator switches turned OFF).
2	Check the rating of the power supply fuses and fuses in the controller cubicles.
3	Check the security of all components inside the cubicles and examine all connections. Inspect for any obvious damage and rectify if necessary.
4	Ensure that all exposed wiring is correctly routed and secure.
5	Verify on the sight glass of all compressors that the oil reaches the top of the glass, if necessary add oil.
6	Ensure all compressor and vessel supply ball valves are fully open, and dryer inlet and outlet valves are fully closed.
7	Ensure that compressor is correctly ventilated and that there are no elements blocking the exhaust grating.
8	Check that the internal CAN cables are in correct order - cable 1 at top position - cable 2 at bottom position.
9	Check the external CAN sockets have the locating key at a 12 o'clock orientation and that the securing nuts are tight.
10	Check that the CAN connector is plugged into slot CAN2 on each compressor (left hand socket).
11	Check manual drain valve within each compressor is closed

CAN address setup.

Power up the compressors and complete the following step on each compressor to set the CAN numbers.

Set the CAN addresses as follows for the number of compressors connected to the Medical Air plant, for up to a maximum of 6 compressors.

Compressor No.	CAN Setting	CAN Address
1	ON	1
2	ON	2
3	ON	3
4	ON	4
5	ON	5
6	ON	6

To change compressor CAN address, on the compressor controller go to:

Menu>Settings>CAN Address (change to # from table above)

Menu>Settings>CAN (Change to [ON])

Plant start up.

See medical air purifier and compressor manuals for detailed start up instructions listed in section 1.

5 Commissioning

Introduction

Commissioning of an Air Plant must be carried out strictly in accordance with the following procedures, which are designed to ensure that the installation is correct and ensure that the Air Plant operates correctly.

The full commissioning procedure must be carried out after the installation before the system is brought into use. The relevant sections of the commissioning procedure must be repeated after major component replacement or whenever the plant operation or performance is suspect. Commissioning must only be undertaken by suitably qualified and competent personnel who are fully conversant with the information contained in this manual. It is recommended that for a full commissioning procedure, the following paragraphs are carried out in strict sequence. This ensures that at each step the plant is correctly set for the next procedure.

Where applicable, a work permit must be obtained before commencing any work on the medical Air system.

These procedures are designed in accordance with EN ISO 7396-1 (e.g. integrity of the pipeline installation, check system design performance and functionally test all components).

Electrical functional check

Following the initial electrical power connection and every time the electrical power supply connections have been disturbed for any reason, all electrical connections must be checked for security and the electrical functional check must be carried out.

1. Connect Verify that each Local/LAN switch is set to Local. Start each compressor briefly by switching on the compressor, while checking the rotation of the motor. A paper, attached to the outlet grating, should rise up if rotation is correct. If the rotation is wrong, switch off the compressor immediately or damage to the compressor element can occur. Switch off and isolate the power supply and swap 2 phase connections in the cubicle. Carry out the procedure again to check for correct rotation. Check that each compressor operates normally without any unusual noise or vibration. Verify that the ampere meter registers full load current.
2. If a motor doesn't rotate during this check, check the connections in the connection box on the motor, and check the connections inside the cubicle. Check the overload settings and the fuses. When the problem is corrected, carry out the rotational check again.
3. Check that the central controller power LED is lit and the controller screen is operational when the supply voltage is connected. Check that the compressor power ON LEDs are lit and the screens are operational when the isolator switches are ON.

Setting the pneumatic system

Prior to checking the automatic operation, the pneumatic system must be selected as follows:

1. Fully open the valves at the outlet of each compressor.
2. Fully open the valves at each vessel connection.
3. Fully close the vessel bypass valves.
4. Fully close both inlet ball valves on the dryer
5. Fully close the (full flow) test connection ball valve on the dryer.
6. Fully close the outlet connection valve which connects the plant to the distribution piping while proving the plant operation (see next chapter).
7. After proving the plant operation, making sure that all terminal units are correctly fitted, and after successfully completing the pipeline carcass pressure test, the outlet connection ball valve can be opened.

Automatic operation & leak check

1. Proceed to the dryer instruction book to start the PureLogic software.
2. Set the Local/LAN switch to LAN on all controllers.
3. Set all isolators to ON, powering the complete system.
4. Observe that the plant fault, plant emergency and pressure fault alarms are active on the dryer. Observe that the EFL warning is active on the compressors (see GA MED instruction book).
5. Observe that the compressors are being called and the pressure on the controllers approaches nominal pressure. Reset the EFL warnings (see GA MED instruction book).
6. Gradually open both inlet valves of the dryer. Ensure both sides are pressurized by observing the pressure gauges present on the dryer.
7. Open the test connection (unplug the plug) slightly to simulate a flow demand (use ear protectors), observe that the compressors respond to maintain pressure.
8. Ensure that each compressor operates normally without any unusual noise or vibration. Should any fault occur, the respective compressor or dryer must be switched off immediately and the fault remedied.
9. Fully close the test connection and refit the plug. When pressure is reached all compressors should stop.
10. Observe that the alarms are now extinguished (except maybe plant emergency/plant fault due to the dew point not being at the expected level yet).
11. Verify the pressure marked on the vessel safety valve. Ensure that a pressure just below the safety valve pressure is maintained for at least 5 minutes. Check for the mechanical integrity of the system. At the same test pressure, the pressure drop after a test period of 2 h to 24 h shall be less than 0,025 % per hour of the initial pressure. The pressure drop shall be corrected for variations due to temperature according to the ideal gas laws (see EN ISO 7396-1 annex E). In case the pressure drop is greater, close off sections of the pipeline, track leaks (audibly or through other means), and fix them. Then redo the test.

After opening the pipeline distribution ball valve, ensure that the system continues to operate within the design flow rate and that the compressors operate normally with no signs of problems for at least one hour.

Per compressors cubicle, read out the value of the drawn nominal current on the amp meter and note down the value.

Setting the pneumatic system

After going through the procedures explained in the previous paragraphs (make sure that the valves are set according to paragraph Setting the pneumatic system in this section, with the outlet ball valve opened), the plant can be left to run automatically. Ensure that all local/LAN switches are set to LAN and that the automatic operation LEDs are lit on every controller. Ensure that the relevant paragraphs in the separate instruction books are followed to start the software. Follow the guidelines explained in the maintenance chapters to ensure trouble free and reliable operation throughout the life of the plant. Inspect the vessels and vessel drains yearly

6 Medical Device Directives

Components subject to 93/42/EC Medical Devices Directive

All components are designed, manufactured and inspected according to the European Directive 93/42/EC annex II and art. 11 par. 3.

Overall rating

The purifier unit conform to the Medical Devices Directive 93/42/EC category IIb.



Atlas Copco Airpower n.v.
Boomsesteenweg 957
2610 Wilrijk - Belgium



ATLAS COPCO MEDICAL LIMITED
Telford Crescent, Staveley, S43 3PF United Kingdom



Document 4233500261 Ref. 02 16/Mar/2021
© Pneumatech Medical Gas Solutions 2015. All rights