

Flexible Pendant

Installation, Operation and Maintenance Manual

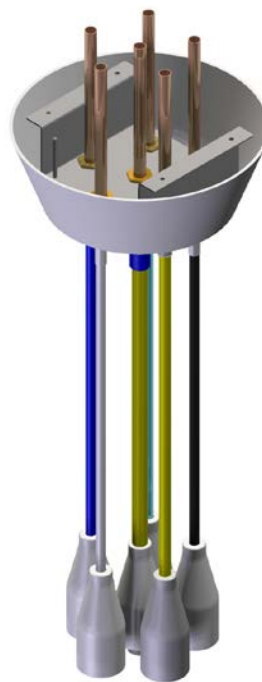

Published by Pneumatech Medical Gas Solutions

All possible care has been taken in the preparation of this publication, but Pneumatech Medical Gas Solutions accepts no liability for any inaccuracies that may be found.

Pneumatech Medical Gas Solutions reserves the right to make changes without notice both to this publication and to the product which it describes.

Copyright © 2015 Atlas Copco All rights reserved.

No part of this publication may be reproduced, transmitted, transcribed, or stored in a retrieval system or translated into any human or computer language in any form or by any means without the prior permission of Pneumatech Medical Gas Solutions.

Important



Personnel must make themselves familiar with the contents of this manual and the function of the unit before installing, operating or maintaining any Flexible Pendants.

Information contained in this manual is correct at the date of publication. The policy of Pneumatech Medical Gas Solutions is one of continuous product improvement. Pneumatech Medical Gas Solutions reserves the right to make changes that may affect instructions in this manual without prior notice.

For any enquiry regarding the servicing or repair of this device, contact the nearest accredited Pneumatech Medical Gas Solutions agent, or communicate directly with:



Pneumatech Medical Gas Solutions
Unit 18 Nuffield Centrum
Nuffield Way
Abingdon
Oxfordshire
OX14 1RL
UK

<http://www.p-mgs.com>

Sales

Tel: + 44 (0) 1235 463010
Fax: +44 (0) 1235 463011
sales@p-mgs.com

Spares

Tel: +44 (0) 1235 463053
Fax: +44 (0) 1235 463011
spares@p-mgs.com

Service

Tel: +44 (0) 1235 463051
Fax: +44 (0) 1235 463011
service@p-mgs.com

Any complaints about the products or services provided by Pneumatech Medical Gas Solutions, please give as much of the following information as possible:

- Product Part Number
- Lot/ Batch Number
- Approximate date of purchase
- Apparent fault.

Complaints

T: +44 (0) 1235 463010
F: +44 (0) 1235 463011
complaints@p-mgs.com

Issue Record

Issue No.	Reason for Change	Pages affected	Date
Rev. 1	Rebranding	All	October 2015

Introduction

This manual contains information needed to install, operate and maintain the Pneumatech Medical Gas Solutions (Pneumatech MGS) Flexible Pendants.

The contents of this manual are intended to be read and used by suitably qualified personnel.

WARNINGS, CAUTIONS and NOTES

The following Warnings, Cautions, and Notes must be read and understood before using the Flexible Pendants.

Warnings!

Warnings tell you about dangerous conditions that could lead to death or serious injury to the user that can occur if you do not obey all of the instructions in this manual.

1. **WARNING! Read through this entire instruction manual before using or showing others how to use this equipment. As with all medical equipment, attempting to use this device without a thorough understanding of its operation may result in patient or user injury.**
1. **WARNING! Do not attempt to modify this device in any way not strictly described within this manual.**
2. **WARNING! Pendants must be protected from access by unauthorised personnel.**
3. **WARNING! No attempt should be made to use this product with a gas service or at a pressure other than as identified.**
4. **WARNING! Do not use this product if it appears damaged in any way.**
5. **WARNING! Do not use this product if there is evidence of contamination internally or on any of gas wetted connections (e.g. debris, particles, oil, lubricants or grease).**
6. **WARNING! This equipment should only be installed, commissioned, operated and maintained by technicians who are suitably trained with medical gas systems, such as Competent or Authorised Persons as defined in UK Department of Health Technical Memorandum No. 02-01 (HTM 02-01).**
7. **WARNING! Ensure that non-interchangeable screw thread (NIST) connections are tightened before use.**
8. **WARNING! Before loosening any pneumatic connection, ensure that the pressure has been isolated.**
9. **WARNING! Risk of fire or explosion: Do not lubricate this product with oil or grease. Safe and compatible lubricants can be obtained from Pneumatech Medical Gas Solutions if required.**
10. **WARNING! Obtain a work permit before commencing any work on medical gas equipment.**
11. **WARNING! Check that each flexible hose assembly is free to rotate within their respective NIST connections without unscrewing the NIST nuts.**
12. **WARNING! Ensure all NIST connections are tight before use and follow the checks in the planned preventative maintenance schedule.**
13. **WARNING! Keep all components dry and clean during installation.**
14. **WARNING! If there is any reluctance of the flexible pendant terminal unit mechanism to operate freely, the outcome shall result in removal of the unit for closer inspection, repair or replacement as necessary.**
15. **WARNING! Do not use oil, grease or jointing compound on any components.**
16. **WARNING! It is recommended that flexible pendant hose assemblies shall be replaced after a service life of three years even if there is no sign of impairment. Flexible**

pendant hose assemblies must not be used in service beyond their indicated replacement date. Hose assemblies are marked with a replacement date. Ensure that hose assemblies are replaced in a timely manner.

Cautions!

Cautions tell you about dangerous conditions that can occur and cause damage to the equipment if you do not obey all of the instructions in this manual.

17. **CAUTION!** Use of sub-standard or inappropriate parts and materials may damage the Pendant System and invalidate the warranty. Only use genuine Pneumatech Medical Gas Solutions spare parts.
18. **CAUTION!** Pressurised air from the medical gas pipeline system may cause personnel injury or property damage if the unit is incorrectly operated or maintained.
19. **CAUTION!** Terminal unit probes, particularly those attached to low-pressure hose assemblies can be ejected from the terminal unit with significant force. Probes, NIST connections or other equipment should be restrained/ supported during removal from a terminal unit to prevent injury or damage.
20. **CAUTION!** Any work involving alteration, extension or maintenance work to an existing system should be subject to the 'Permit to Work' procedure detailed in HTM 02-01.
21. **CAUTION!** Tighten all NIST connections, but do not over-torque face seal fittings.
22. **CAUTION!** Leak detection fluids contain surface active agents (surfactants) that can damage plastic components under stress. Only use leak detection fluids that are compatible with the materials being tested.
23. **CAUTION!** Only use leak detection fluids that are compatible with the materials being tested.
24. **CAUTION!** Always wash leak detection fluids off with clean water immediately after use.
25. **CAUTION!** Nickel plating may cause a mild localised allergic skin reaction in some people.
26. **CAUTION!** Any work involving alteration to an existing system should be subject to the *Permit to Work* procedure detailed in HTM 02-01.
27. **CAUTION!** Do not over-torque O-ring and face seal connections.

Notes:

1. All information, specifications and illustrations within this manual are those in effect at the time of printing.
2. The manufacturer reserves the right to change or make improvements without notice and without incurring any obligation to make changes or add improvements to products previously provided.
3. All information, specifications and illustrations within this manual are those in effect at the time of printing.

Abbreviations used

The following abbreviations are used in this manual:

Abbreviation	Full name
MGS	Medical Gas Solutions
HTM	Health Technical Memorandum
NIST	Non-Interchangeable Screw Thread
BS EN	British Standard European Standard
East, Zeus, SP	Terminal units
AGS	Anaesthetic Gas Scavenging
NHS	National Health Service
AGSS	Anaesthetic Gas Scavenging System
AVSU	Area Valve service Unit
Kg	Kilogram
mm	millimetre
RH	Relative Humidity
kPa	Kilopascal
GMDN	Global Medical Devices Nomenclature
EC MDD	EC Medical Device Directive
GHTF	Global Harmonisation Task Force

Scope of this manual

This manual describes the Operation Service, Repair and Testing of the Pneumatech MGS Flexible Pendant.

Pneumatech Medical Gas Solutions service contact

In the event of any queries or problems that cannot be resolved using information in this manual, please call:

+44 (0) 1235 463051

Quote if possible, the:

- Product part number
- Lot/ Batch number
- Approximate date of purchase
- Apparent fault

Contents

Flexible Pendant	1
Issue Record.....	2
Introduction	2
WARNINGS, CAUTIONS and NOTES	2
Warnings!.....	2
Cautions!.....	3
Abbreviations used.....	4
Scope of this manual.....	4
Pneumatech Medical Gas Solutions service contact	4
Safety Features.....	7
Storage	7
Environmental Conditions	7
1 Description	8
1.1 Features.....	8
1.1.1 Services	9
2 Technical Specification	10
3 User Responsibility	11
4 Description of Symbols	11
5 Technical Information	12
5.1 Principle of Operation.....	12
5.1.1 Flexible Pendants	12
6 Installation and Commissioning	12
6.1 General Requirements	12
6.2 Components.....	12
6.3 First Fix Installation	13
6.4 Second Fix Installation	13
7 Commissioning	17
7.1 Introduction	17
7.2 Proving the Flexible Pendant Hose Assembly	18
7.2.1 Part 1.....	18
7.2.2 Part 2.....	18
8 Operating Instructions	18
8.1 Terminal Units	18
9 Maintenance	19
9.1 Introduction	19
9.2 Tools and Equipment	19
9.3 Routine Inspection, Checks and Maintenance.....	19
9.4 Annual Inspection.....	20
9.5 Year Major Overhaul	20
9.6 Component Replacement and Adjustment	20
9.6.1 Flexible Hose Assembly Replacement	21
9.7 Cleaning.....	22
10 Fault Diagnosis	22
10.1 Introduction.....	22
11 Recommended Spares	24
12 Declaration of Conformity	25

Safety Features

Flexible pendant hose assemblies are connected to the first fix ceiling NIST via flexible hoses with NIST connections. This ensures that it is impossible to interchange gas specific services.

Other Essential Features

The Pneumatech MGS Flexible Pendants are ceiling mounted units designed to provide medical gas services from a convenient overhead location, where space is at a premium as in operating theatres and recovery rooms. The use of overhead flexible pendants provides a cost effective solution to avoid dangerous trailing hoses in the workplace.

Storage

All products are separately packaged and stored under controlled conditions.

Identification

A small identification label is affixed to parts of the Flexible Pendant (see Figure i), but can only be viewed when the Pendant and/ or Terminal shrouds are moved out of position.



Figure i Identification Label

Environmental Conditions

Pneumatech MGS Flexible Pendants can be safely handled and stored under normal working and environmental conditions.

Adverse environmental conditions and harsh abrasives or chemicals may cause damage to the unit.

1 Description

1.1 Features

The Pneumatech MGS Flexible Pendants are ceiling mounted units designed to provide medical gas services from a convenient overhead location, where space is at a premium as in operating theatres and recovery rooms. The use of overhead flexible pendants provides a cost effective solution to avoid dangerous trailing hoses in the workplace.

Pneumatech MGS Flexible Pendants connects fixed medical gas pipeline installations from ceiling level to East, Zeus or SP terminal units located at head height. A maximum of six medical gas or vacuum terminal units can be accommodated including anaesthetic gas scavenging (AGS). Terminal units are located radially with the anaesthetic gas scavenging (AGS) terminal unit located centrally. Flexible pendant hose assemblies are connected to the first fix ceiling NIST via flexible hoses with NIST fittings to ensure that it is impossible to interchange the services.

Pneumatech Flexible Pendants house BS EN 9170 Terminal Units. The terminal units are constructed and operate in the same way as a wall mounted unit except they do not contain an anti-rotation pin.

All gas hoses are colour coded and have the appropriate NIST fittings permanently attached.

Pneumatech MGS Flexible Pendants comply with NHS Estates Health Technical Memorandum 2022 and 02-01 and the design requirements of NHS Estates Model Engineering Specification C11 and in accordance with British Standards; Hose assemblies and NIST connections conform to BS EN 15908 and BS EN 5359. Terminal units conform to BS EN 9170 accepting gas specific probes to BS 5682.

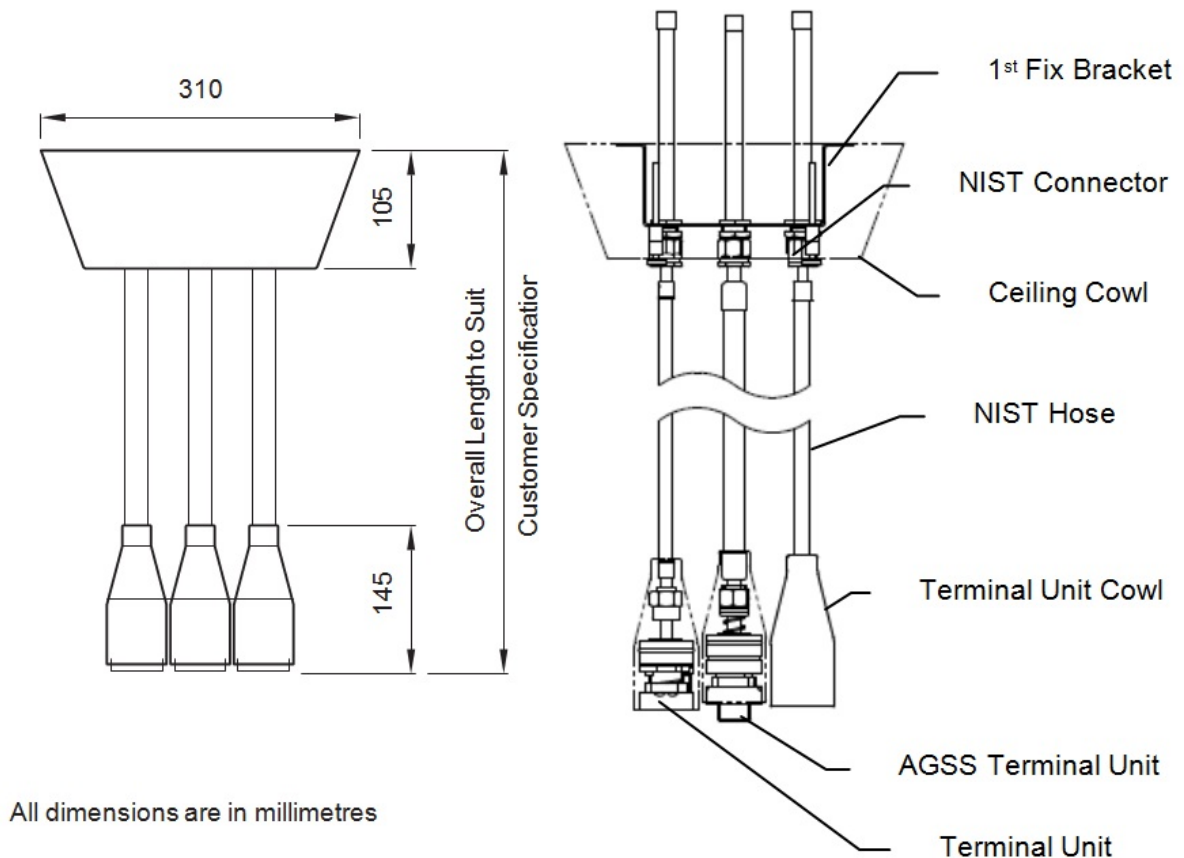

Figure 1-2 Flexible Pendants – General view

1.1.1 Services

A maximum of six medical gas/ vacuum services are positioned radially in the following sequence, starting clockwise when viewed from below with AGSS mounted centrally (in accordance with HTM 02-01):

- Oxygen
- Nitrous Oxide
- 50%Oxygen 50% Nitrous Oxide
- Medical air
- Surgical air
- Nitrogen
- Carbon Dioxide
- Vacuum
- AGSS

Each medical gas/ vacuum service is transmitted through the hose assembly. The PureHose Pf – Phthalate free medical gas hose assemblies terminate with gas specific NIST fittings and are colour coded appropriate to the medical gas service in accordance with *Table 2-2*. Hoses are supplied to a specified length.

The upper end of the flexible hose connection is via a NIST connection to the SP first fix ceiling NIST assembly which holds the non-return valve fully open.

The lower end of the flexible hose is connected by a NIST connection to the mating gas specific Pneumatech MGS Terminal Unit. Each terminal unit is protected by a white plastic shroud which protects terminal units from dirt, dust and moisture as well as offering a buffer to prevent clashing from adjacent terminal units:

2 Technical Specification

Table 2-1 Technical Specifications

Flexible Pendants	
Physical Characteristics:	
Height	To customer specification
Width	310 mm
Depth	310 mm
Weight:	16 kg (five gas and AGSS)
Environmental Transport, Storage and Operating Conditions:	
Temperature	10 to 40 °C
Humidity	10 to 95 % RH Non-condensing
Air Pressure	70 to 110 kPa
Performance:	
Working Pressure	Varies with model (see <i>Table 2-2</i>)
Regulatory Classification:	
GMDN Code (Term)	36271 (Medical gas and vacuum supply systems)
EC MDD Classification	Class IIb
GHTF Classification	Class C

The operating pressure ranges of the terminal units are as shown in the *Table 2-2*.

Table 2-2 Gas Service, Operating Pressure Range and Colour Coding of Hose Assemblies

Gas Service	Operating Pressure Range	Colour Coding of Hoses
Oxygen	0-400 kPa	White
Nitrous Oxide	0-400 kPa	Blue
O ₂ /N ₂ O 50%/50%	0-400 kPa	White / Blue
Medical Air	0-400 kPa	Black with a White / Black band at each end
Surgical Air	0-800 kPa	Black with a White / Black band at each end
Carbon Dioxide	0-400 kPa	Grey
Nitrogen	0-800 kPa	Black
Medical Vacuum	40 kPa (absolute pressure)	Yellow
AGSS	20 kPa (absolute pressure)	Yellow with a Yellow/Blue band

3 User Responsibility

This device has been built to conform to the specification and operating procedures stated in this manual and/ or accompanying labels and notices when checked, operated, maintained and serviced in accordance with these instructions.

To ensure the safety of this device it must be checked and serviced to at least the minimum standards laid out in this manual. A defective or suspected defective product must not be used under any circumstances.

The user must accept responsibility for any malfunction which results from non-compliance with the servicing requirements detailed in this manual. Additionally, the user must accept responsibility for any malfunction which may result from misuse of any kind, or non-compliance with other requirements detailed in this manual.

Worn, broken, distorted, contaminated or missing components must be replaced immediately. Should such a repair be necessary, it is recommended that a request for service advice be made to the nearest Pneumatech Medical Gas Solutions Service Centre.

This device and any of its constituent parts must be repaired only in accordance with written instructions issued by Pneumatech Medical Gas Solutions and must not be altered or modified in any way without the written approval of Pneumatech Medical Gas Solutions.

The user of this equipment shall have the sole responsibility for any malfunction which results from improper use, maintenance, repair, damage or alteration by anyone other than Pneumatech Medical Gas Solutions or their appointed agents.

4 Description of Symbols

WARNING! Warnings tell you about dangerous conditions that could lead to death or serious injury to the user that can occur if you do not obey all of the instructions in this manual.

CAUTION! Cautions tell you about dangerous conditions that can occur and cause damage to the equipment if you do not obey all of the instructions in this manual.

Note: Emphasises points that might allow more convenient or efficient operation of the device.

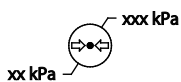

Ambient pressure range - kPa

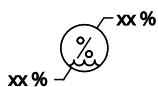

Ambient humidity range - %



Ambient temperature range - °C



Consult accompanying documents



The CE mark demonstrates that Pneumatech MGS Flexible Pendants conform to the requirements in the European Council Directive 93/42/EEC concerning medical devices.

The number 0088 identifies the notifying body under which the Quality Systems operated within Pneumatech MGS.

5 Technical Information

5.1 Principle of Operation

5.1.1 Flexible Pendants

The Pneumatech MGS Flexible Pendant consists of a first fix installation kit (including mounting bracket), SP first fix ceiling NIST assembly and second fix hose and terminal unit assembly. Shrouds are included within the kits to provide a neat appearance at ceiling level and between the hose and terminal unit connection.

The first fix mounting bracket is attached to the supporting structure by four suitable fixings and provides the mounting for the first fix ceiling NIST assemblies. First fix ceiling NIST assemblies terminate in a NIST fitting specific to each gas service. The first fix NIST includes a self-closing non-return valve to allow safe removal of hoses for maintenance without disruption to the gas supply. The non-return valve is held open when the second fix hose assembly is connected.

6 Installation and Commissioning

WARNING! Keep all components dry and clean during installation.

The pendants should be installed by competent persons as defined in HTM 02-01.

1. Particular care should be taken when installing pendants with more than one gas, to ensure that each gas specific NIST is connected to the correct gas supply pipeline.
2. Checks should be carried out using gas flow and identity tests to ensure the above (1) is correct.
3. Care should be taken to ensure all mechanical fixings/ mountings including NIST connections are secure (parts that leave the factory secure may become loose during transit).
4. Caution is advised whilst cleaning the units to prevent ingress of liquid into the flexible pendant hose and terminal unit assemblies.

6.1 General Requirements

Pneumatech MGS Flexible Pendants are normally supplied as a first and second fix, with all components tested in the factory. Flexible pendants are manufactured to customer's specifications to provide a clearance of 2000 mm above the finished floor level.

The flexible pendant first fix bracket must be securely fixed to the soffit in order to provide suitable support for the weight of the pendant, which will vary according to the length of the hose assembly and the forces it will incur during service. All securing bolts must be adequate for the load of the pendant and any framework must be designed for rigidity. Even small loads such as those imposed by inserting gas probes can cause large deflections.

The first fix is typically bolted to steelwork or the concrete slab of the floor above. Medical gas and vacuum services can then be terminated at the first fix ceiling NIST assemblies within the ceiling void, before the second fix flexible pendant hose assemblies are installed.

Gas services **MUST** be terminated with NIST connectors at the first fix plate.

If the pendant is installed as a first fix item early in the construction of the theatre/ recovery room, care should be taken to protect the external finish from damage by subsequent work.

6.2 Components

Unpack and inspect all components, ensuring that all the following have been supplied:

- Flexible Pendant Installation Kit, including;

Table 6-1 Flexible Pendant Installation Kit

Description	Quantity
Spacer	8-off
Screw cover and washer	4-off
Plastic blanking plug	5-off
6-Gas flexible pendant shroud	1-off
Ceiling mounted first fix bracket	1-off
M5 x 90 slot countersunk head screws	4-off

- SP First Fix Ceiling NIST Assemblies
- Second Fix Hose and Terminal Unit Assemblies

6.3 First Fix Installation

Note: Numbers in brackets (#) refer to *Figure 6-1. Flexible Pendant Exploded Layout*, *Figure 6-2 and 6-3 Flexible Pendant Installation Detail* illustrate the complete flexible pendant installation detail.

1. Using 6 mm anchor bolts, or equivalent, secure the first fix bracket (1) to a support structure (ref. *Figure 6-2 Flexible Pendant First Fix Bracket Installation Detail*).
2. Remove the NIST blank nut, seal and lock nut (3) from each SP first fix ceiling NIST assembly (2). The first fix mounting bracket houses the first fix ceiling NIST assemblies which must be fed through the underside of the bracket (ref. *Figure 6-1 Flexible Pendant Exploded Layout*).
3. Medical gas/ vacuum services are positioned radially in the following sequence, starting clockwise when viewed from below with AGSS mounted centrally:
 - Oxygen
 - Nitrous Oxide
 - 50%Oxygen 50% Nitrous Oxide
 - Medical air
 - Surgical air
 - Nitrogen
 - Carbon Dioxide
 - Vacuum
 - AGSS
4. Secure the SP first fix ceiling NIST assemblies using the lock nut.
5. Braze the stub pipe to the distribution pipeline. Fit the seal and NIST blank.
6. Complete Part 1 (para.7.2.1) of the commissioning procedure on completion of installation.

6.4 Second Fix Installation

Prepare the six-gas flexible pendant (5); if less than six services are to be used in the installation, fit plastic blanking plugs (8) to fill redundant holes. (ref. *Figure 6-4 Flexible Pendant Second Fix Installation Detail*)

1. Ensure that the first fix plate is securely in place and the NIST connectors are installed. Feed the second fix flexible pendant hoses (9), non-terminal unit end through the ceiling shroud. Check that each gas service is correctly mated with the reciprocating gas service.
2. Ensure that an O - ring seal is correctly located within each flexible hose assembly NIST fitting as shown in *Figure 6-4 Flexible Pendant Second Fix Installation*.

3. Connect all flexible hose assemblies to their reciprocating gas specific first fix assembly. Tighten all NIST connections, but do not over-torque.
4. Pre-assemble the M5 screws (7) and washers (6) and insert through the six-gas pendant shroud. Locate the 8-off spacers (4) and place between the first fix plate and the screws protruding through the 6-gas flexible pendant shroud and retain in position. Tighten connections, but do not over-torque. Place screw covers (6) over washers.

The installation is almost complete. Lift the terminal unit shroud (10) located within the flexible pendant hose assembly and check the NIST nut (11) is tight as this pre-assembled connection may have become loose in transit.

WARNING! Check that each flexible hose assembly is free to rotate within their respective NIST connections without unscrewing the NIST nuts.

WARNING! Ensure all NIST connections are tight before use and follow the checks in the planned preventative maintenance schedule.

Complete Part 2 (*para. 7.2.2*) of the commissioning procedure on completion of the installation.

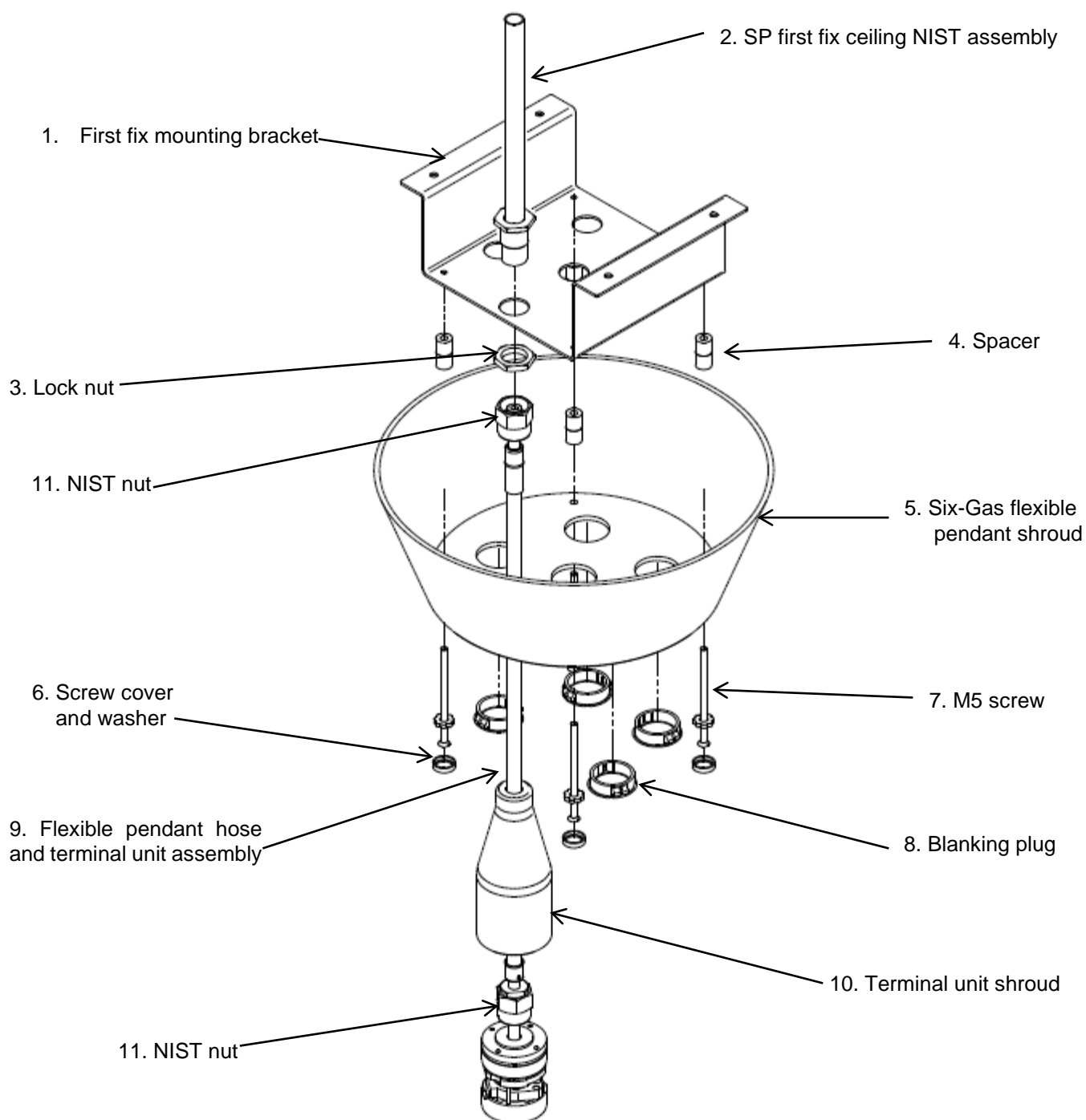

Figure 6-1 Flexible Pendant Exploded Layout

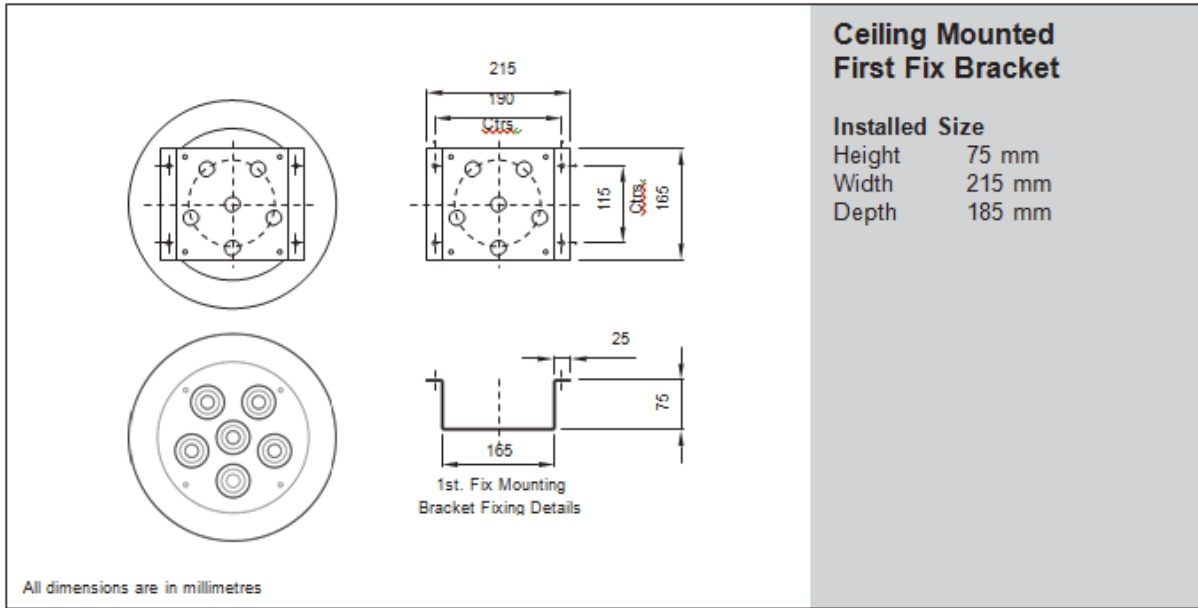

Figure 6-2 Flexible Pendant First Fix Bracket Installation Detail

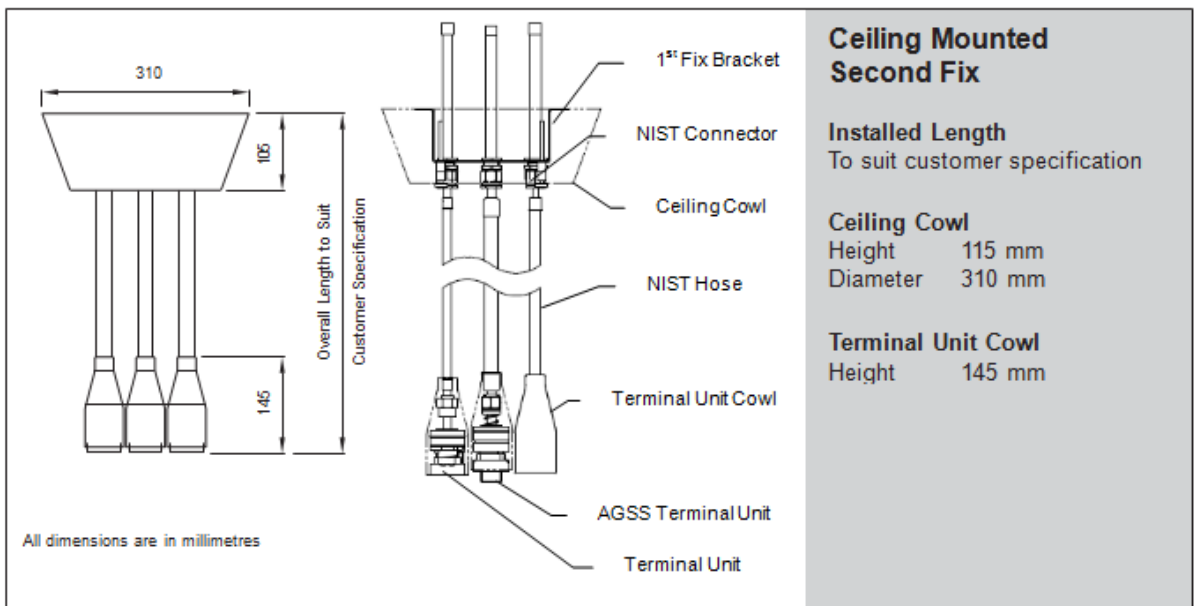
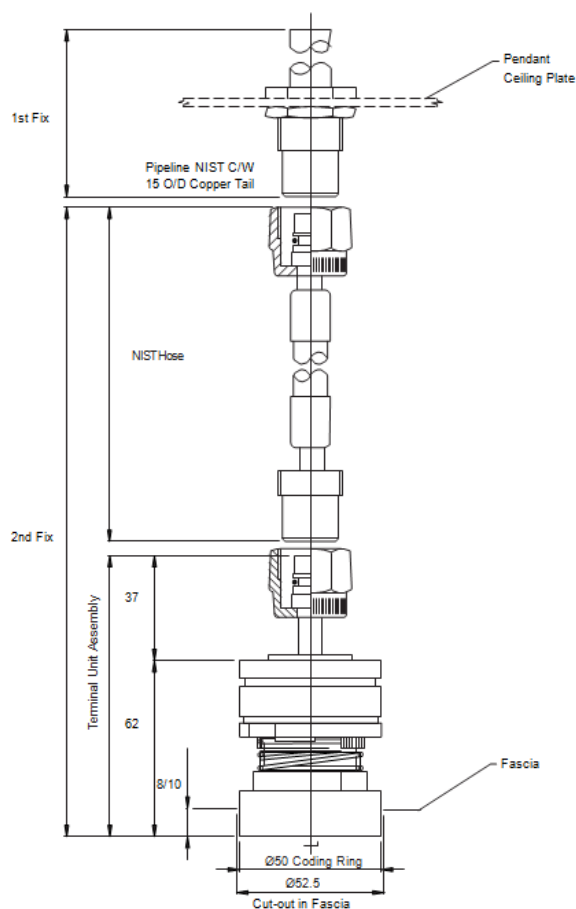

Figure 6-3 Flexible Pendant Installation Detail



All dimensions are in millimetres

Figure 6-4 Flexible Pendant Second Fix Installation Detail

7 Commissioning

7.1 Introduction

Commissioning in full must be carried out after initial installation, after a major component change, and as part of a planned preventative maintenance programme. The objective of testing and commissioning is to ensure that all the necessary safety and performance requirements of the medical gas pipeline system shall be met in accordance with HTM 2022 and HTM 02-01.

Commissioning is typically carried out in two parts;

Part 1 is performed after installation of the pipeline carcass but before concealment and consists of; visual check of pipeline labelling, marking, sleeving and support; leakage test and tests for cross-connection.

Part 2 is performed after complete installation of the pipeline system and consists of; test for leakage; tests for cross-connection, flow, pressure drop, mechanical function and correct identity of the terminal units; tests for mechanical function and identity of NIST connectors; performance tests of the pipeline system, tests for particulate contamination/ odour/ taste.

Purging and testing the medical gas pipeline system must be carried out with clean, oil-free, dry air or nitrogen, except for those tests where medical air or the specific working gas is prescribed e.g. gas identification, quality and purity checks.

Personnel carrying out the commissioning procedure must be qualified and fully conversant with the full test procedures detailed in HTM 2022 and HTM 02-01.

7.2 Proving the Flexible Pendant Hose Assembly

Following installation of all Pneumatech Medical Gas Solutions first fix assemblies, the medical gas pipeline must be purged to remove all particulate matter and subjected to a series of checks and tests in accordance with British Standards and CE regulations, which includes the following:

7.2.1 Part 1

1. Ensure the correct first fix ceiling NIST assemblies are installed and located in accordance with the installation specification.
2. Check that each first fix ceiling NIST assembly incorporates the correct gas specific NIST fitting.
3. Ensure that a blank NIST nut and sealing washer is fitted to each first fix ceiling NIST assembly.
4. NIST blanking nuts shall remain fitted to prevent ingress of foreign matter until the second fix is assembled.
5. Perform pipeline carcass pressure testing in accordance with the installation contract and HTM 2022 and HTM 02-01 as applicable.

Following installation of all second fix assemblies each medical gas service must be commissioned in accordance with the installation contract and HTM 2022 and HTM 02-01.

7.2.2 Part 2

1. Test for leakage on each medical gas pipeline system.
2. Test for cross-connection.
3. Test the mechanical function and gas specificity of terminal units.
4. Test for flow and pressure drop across terminal units and hose assemblies.
5. Test for correct gas identification, quality and purity checks.
6. Check hose NIST fitting for correct gas specification.
7. Check hose fittings are stamped with gas identification and BS number.
8. Check the second fix with the gas specific probe.
9. Check the position of terminal units is in accordance with the customer specification, hose lengths and overall length of the flexible pendant assembly is correct.
10. Inspect the general finish of the pendants.

Note: New terminal units are supplied with *Do not use* labels. These labels should remain in place until the final identity and quality tests have been completed. They may only be removed by the Authorised Person.



Figure 7-1 Do Not Use Label

8 Operating Instructions

8.1 Terminal Units

The terminal units are constructed and operate in a similar way as a wall mounted unit, except they do not contain an anti-rotation pin. Pneumatech MGS East and Zeus Terminal Units will only accept the correct BS 5682 Medical Gas Probe.

To obtain a gas flow, the correct medical gas probe is inserted into the terminal unit. A slight push on the probe inwards completes engagement; the probe is locked into position via two roller pins. Fully

engaging the probe opens the check valve to permit the specified gas flow. A gas seal is made between the probe and check valve assembly (housed in the second fix socket), through the plunger retaining O-ring. The probe makes contact with the valve plunger, compressing the plunger spring. The check valve fully opens displacing the maintenance valve allowing the flow of gas to pass through the probe.

To remove the probe:

1. Hold the probe between the middle finger and palm.
2. Ease the probe inwards to reduce the load on the roller pins and press the terminal unit fascia ring firmly with your thumb and index finger.
3. The probe shall eject from the terminal unit and the check valve seals to close the gas flow.

Pneumatech MGS AGSS Terminal Units are gas specific and shall only accept BS 8532:2011 probes. Inserting the AGSS receiver unit probe and engaging the retaining nut opens the valve adjuster by compressing the spring allowing full gas flow through the probe and terminal unit. Removal of the probe enables the spring loaded plunger adjuster to seal against the terminal unit barrel forming a seal.

Note: Carbon Dioxide and Nitrogen terminal units operate using the same method as AGSS but shall only accept BS EN 15908:2010 NIST connectors.

For further details refer to the Installation, Operation and Maintenance Manual for Zeus and East terminal units (*part no. 6000414*).

9 Maintenance

9.1 Introduction

Pneumatech MGS pendant systems are designed to operate with the minimum of maintenance, however regular routine minor maintenance operations are recommended to prove the system integrity.

Maintenance operations are carried out in accordance with the planned preventative maintenance contract purchased by the customer. Maintenance engineers must fully understand the pendant system and must be conversant with the information contained in this manual.

The terminal units within the pendants require regular checks to ensure they are not leaking or have become damaged during use. Refer to Terminal Units Operation, Installation and Maintenance Manual for a full description of maintenance requirements.

WARNING! Use of sub-standard or inappropriate parts and materials may damage the pendant and invalidate the warranty.

WARNING! Only use genuine Pneumatech Medical Gas Solutions spare parts.

WARNING! Obtain a work permit before commencing any work on medical gas equipment.

9.2 Tools and Equipment

No special tools are required, however all common hand tools used must be clean, completely free of oil and grease and checked for serviceability before commencing maintenance procedures. All necessary spare parts must be obtained before commencing work.

9.3 Routine Inspection, Checks and Maintenance

Minimum requirements for routine inspections, checks and maintenance are given in *Table 9-1 Inspection and Maintenance Schedule* and must be observed in full to ensure continued safe operation of the system.

9.4 Annual Inspection

The commissioning procedure detailed in *Section 7, Commissioning* should be completed after replacement of any functional component and at least annually to prove the system is operating as normal and there are no faults present.

9.5 Year Major Overhaul

In order to ensure continued safe operation of the system, a major overhaul must be carried out every 3 years to replace components subject to significant stress, wear, creep and fatigue. The components that must be replaced are detailed in *Table 9-1*.

Table 9-1 Inspection and Maintenance Schedule

5 Yearly	3 Yearly	Annually	Quarterly	Weekly	Daily	Commissioning	Actions
							Inspection, Checks and Tests:
							Suitability of location
		■					Adequate access for maintenance
							Planned Preventative Maintenance:
		■					Complete Commissioning Procedure
			■				Check terminal units are complete and inspect for damage
			■	■			Check correct gas identification labeling and colour coding
			■	■			Check gas specificity using test probes
			■	■			Check for retention of the test probe
			■	■			Check for smooth release of test probe
			■	■			Check the release mechanism operates freely
			■	■			Check terminal units are leak free
			■	■			Check all NIST connections under the terminal unit shroud are tight
							Check security of fixings/mountings
			■				Check flow and pressure drop performance
			■	■			Check for correct non anti-swivel specification
							Check for freedom of rotation
							Inspect the hose assembly for any defects
							Check O-ring seals
							Component Replacement
							All gas seal kits and Check valve assembly
							Hose assembly replacement

9.6 Component Replacement and Adjustment

WARNING! If there is any reluctance of the flexible pendant terminal unit mechanism to operate freely, the outcome shall result in removal of the unit for closer inspection, repair or replacement as necessary.

WARNING! Do not use oil, grease or jointing compound on any components.

9.6.1 Flexible Hose Assembly Replacement

WARNING! It is recommended that flexible pendant hose assemblies shall be replaced after a service life of three years even if there is no sign of impairment. Flexible pendant hose assemblies must not be used in service beyond their indicated replacement date. Hose assemblies are marked with a replacement date. Ensure that hose assemblies are replaced in a timely manner.

Note: Replacement flexible hoses are manufactured to a specific length, tested and supplied with NIST fittings attached. On-site repairs other than by replacement are not authorised.

Before attempting to replace a flexible pendant hose, check that the replacement hose assembly has been manufactured to the correct specification, including length, colour coding (in accordance with *Table 2-2*) and correct NIST fittings permanently attached. If feasible, the medical gas service should be isolated by closing the appropriate Area Valve Service Unit.

1. Remove the flexible pendant ceiling shroud (1). Feed the ceiling shroud down the flexible hose (2) for access to the upper NIST fitting (3).
2. Disconnect flexible hose upper NIST fitting, carefully supporting the hose until the check valve seals the gas flow. Feed hose through the ceiling shroud.

CAUTION!

The check valve relies on a metal to metal seal and therefore is expected to leak slightly upon removal of the hose.

3. Disconnect the terminal unit (4). Feed the terminal unit shroud (5) up the hose to gain access. Unscrew the terminal unit from the flexible pendant hose at the NIST connection (6).
4. Inspect the replacement hose for correct length, colour coding and NIST connections. Ensure that a serviceable O-ring is fitted to the flexible hose upper connection and the terminal unit NIST fitting.
5. Reconnect the terminal unit to the replacement hose and tighten the NIST fitting.
6. Reconnect the terminal unit and hose assembly. Feed hose through the ceiling shroud. Connect the upper NIST fitting and tighten.

WARNING!

Check the flexible hose assembly is free to rotate within the upper NIST connection without unscrewing the NIST nut.

7. Check all disturbed connections for leaks when gas services/ vacuum is operating at normal pressure.
8. Refit the flexible pendant ceiling shroud. Locate ceiling shroud in position and secure: tighten all fixings.

WARNING!

Check the terminal unit assembly is free to rotate within the flexible pendant hose assembly without unscrewing the NIST nut.

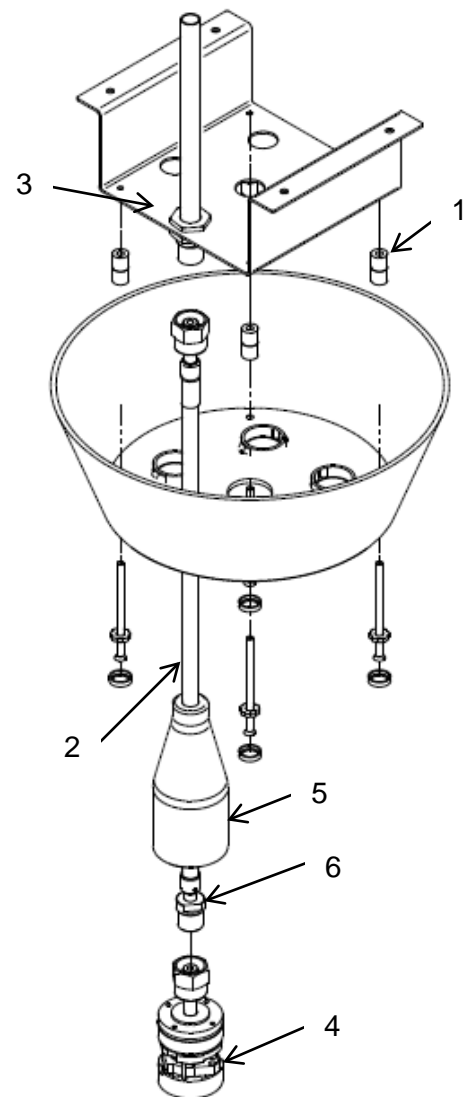

Figure 9-1 Hose Replacement

9. Refit the terminal unit shroud ensuring the shroud is firmly held in position via the terminal block outer O-ring.
10. Perform functional checks on the terminal unit. Complete a quarterly inspection in accordance with *Table 9-1* on all replacement hose assemblies.

9.7 Cleaning

The use of abrasive or solvent based cleaning solutions is not recommended. Should the external surface of the unit require cleaning we recommend the use of a damp cloth or mild soap solution, for the stainless steel plates use Alco-wipes ONLY.

Do not use any phenol or halogen based disinfectants or agents that release chlorine or oxygen.

10 Fault Diagnosis

10.1 Introduction

The flexible pendant and terminal unit mechanisms are extremely robust and if they fail to operate smoothly, it is probably mechanically damaged and should be replaced.

Tables 10-1 to 10-5 detail possible defects/ symptoms which may occur with the flexible pendant assemblies with the necessary rectification action.

Table 10-1 Leaking Terminal Unit

Possible Cause	Remarks/ rectification action
Worn O-rings	Replace check valve assembly and/ or seal plate O-ring
O-ring cut	Check probes for damage and replace as required

Table 10-2 Low Pressure and Flow at Terminal Unit

Possible Cause	Remarks/ rectification action
Regulator settings have drifted	Check regulators and make any necessary adjustments to correct settings.
Isolation valves not fully open	Check isolation valves are fully open.
Foreign object in terminal unit restricting gas flow	Remove socket and check valve assembly, inspect the terminal unit to ensure it is clean, serviceable and free from foreign objects. Replace check valve assembly and or seal plate O-ring.
Damage/ leaking medical gas pipeline system	If the pressure and flow rate remains low with serviceable terminal units fitted, the fault could be directed at the medical gas pipeline system. Inspect the distribution system for damage/ leakage. Repair the pipeline and perform commissioning procedures on the system affected.

Table 10-3 Terminal Unit Stiff or Difficult to Operate

Possible Cause	Remarks/ rectification action
Damaged probe	Check probes for damage and replace as required.

Foreign objects causing interference with locking mechanism	Inspect parts for foreign objects and remove. Check for damage and replace the 2 nd fix assembly if necessary. Test the terminal unit for correct functionality using a serviceable test probe.
Mechanical damage inside the terminal unit	Replace the 2 nd fix and check valve assemblies and functionally test using a serviceable test probe.

Table 10-4 Leaking Hose Assembly

Possible Cause	Remarks/ rectification action
Worn O-rings/ damaged O-ring	Replace O-ring seal.
Leaking NIST connection	Disconnect flexible hose and replace O-ring seal. Do not attempt to cure leak by over tightening.

Table 10-5 Low Pressure/ Flow Rate

Possible Cause	Remarks/ rectification action.
Flexible hose NIST connections leaking	Check all NIST connections. Replace O-ring seals if necessary. Do not attempt to cure a leak by over tightening.
Leaking NIST connection	Disconnect flexible hose and replace O-ring seal. Do not attempt to cure leak by over tightening.
Damaged or blocked flexible hose	Inspect hose assembly for damage or blockage and remove foreign object. Replace hose assembly as necessary
Damaged or leaking pipeline system	<p>If the pressure and flow rate remains low with serviceable hose assemblies, the fault could be directed at the medical gas pipeline system.</p> <p>Check other terminal units within the system and attempt to isolate the area.</p> <p>Ensure the appropriate AVSU or Line Valves are fully open.</p> <p>Ensure the source equipment is serviceable and delivering the correct design pressure and flow.</p> <p>Inspect the distribution system for damage/ leakage. Repair the pipeline and perform commissioning procedures on the system affected.</p>

Note: Failure through misuse or abuse is usually not repairable, and is not covered by the manufacturer’s warranty.

11 Recommended Spares

Pneumatech MGS flexible pendant hose assemblies are expected to provide trouble-free service without the need for a large holding of spare parts. The only recommended holding of spares is detailed in *Table 11-1*.

Note: Overseas customers should take into account extended delivery times.

Table 11-1 Minimum Recommended Spares Scheduling

Description	Part Number
All gas seal kit – SP Terminal Units	360204
Terminal unit check valve assembly – Service Replacement Kit	5005607
AGSS SP Terminal Unit Seal Kit	3260197
Carbon Dioxide and Nitrogen SP Terminal Unit Seal Kit	6000447
Hose Assemblies – Pendant Specific	Contact Spares Department

Spares Department:

T: +44 (0) 1235 463053

F: +44 (0) 1235 463011

spares@p-mgs.com

12 Declaration of Conformity

Declaration of Conformity

Manufacturer	Atlas Copco Ltd. trading as Atlas Copco Medical 18 Nuffield Centrum, Nuffield Way, Abingdon, OX14 1RL, UK
Product	Flexible Ceiling Mounted Pendants
Classification	Ila
Conformity Route	Annex II
Quality Management System	EN ISO 13485:2012
GMDN Code	36271
GMDN Term	Medical gas and vacuum supply systems
Standards Applied	BS 1041, BS 5682, BS 8532, EN 15223-1, EN ISO 5359, EN 15908, EN ISO 9170-1, EN ISO 9170-2, EN ISO 15001, EN ISO 14971
Notified Body	Lloyd's Register Quality Assurance Limited, 71 Fenchurch Street, London EC3M 4BS United Kingdom (LRQA Notified Body Number 0088)
MDD Certificate(s)	LRQ 4007749/C
Start of CE Marking	3 rd April 2013
Place and Date of Issue	Abingdon, 3 rd September 2015

We hereby declare that the above mentioned products meet the provisions of the Council Directive 93/42/EEC concerning Medical Devices, as amended by Directive 2007/47/EC. All supporting documentation is retained under the premises of the manufacturer.

Endorsing Signature
Turgay Ozan (General Manager)



Document ref.: RDOC0012v6.docx

Pneumatech Medical Gas Solutions

Unit 18 Nuffield Way
Abingdon
Oxfordshire
OX14 1RL UK

Sales

T: +44 (0) 1235 463010
F: +44 (0) 1235 463011
sales@p-mgs.com

Spares

T: +44 (0) 1235 463053
F: +44 (0) 1235 463011
spares@p-mgs.com

Service

T: +44 (0) 1235 463051
F: +44 (0) 1235 463011
service@p-mgs.com

Document: 8102341057 Rev 1
Revision issue date: 10 2015

© Atlas Copco 2015. All rights reserved.

