



BEACONMEDÆS™

Series B Chemetron-Type Quick-Connect Latch-Valve Assembly

Installation Instructions

Part Numbers:
230950-00 through 230959-00

CAUTION:

Keep the latch-valve assembly free of oil, grease and other contaminants during installation.

Installation in Concealed Outlet Rough-In Assemblies

NOTE:

The latch-valve assembly and coverplate should be installed after the walls have been finished.

1. Select the service indexed and labeled latch-valve assembly to match the correspondingly indexed and labeled concealed outlet rough-in assembly already installed.
2. Remove the protective dust cover from the rough-in assembly. Remove the seal plug from vacuum or WAGD service rough-in assemblies, where applicable.
3. Installing the coverplate and latch-valve assembly (Figure 1):
 - a. The upper and lower mounting screws along with a yellow caution label are held in place by rubber gaskets. **Read the caution label.**
 - b. Orient the latch-valve assembly with the service label on top and place it inside the coverplate opening.
 - c. Position the combined latch-valve assembly and coverplate over the matching service indexed and labeled outlet rough-in assembly. Align the indexing pin on the latch-valve assembly with the indexing hole in the rough-in assembly. Push the connector on the latch-valve assembly into the outlet block opening in the rough-in assembly until the coverplate is flush against the finished wall.
 - d. Alternately tighten the latch-valve assembly mounting screws until the coverplate is held snug against the finished wall. Adjacent coverplates can be aligned by placing a straight edge along the bottom of all coverplates while tightening the screws.

CAUTION:

Start the mounting screws by hand before using a power driver. Do not overtighten the mounting screws. Doing so can distort the latch-valve and rough-in assemblies. Distortion may adversely affect the operation of the release mechanism.

4. Verify that the latch-valve assembly meets all applicable codes or standards (e.g. NFPA 99 or CAN/CSA-Z305.1) after installation in the concealed outlet rough-in assembly.

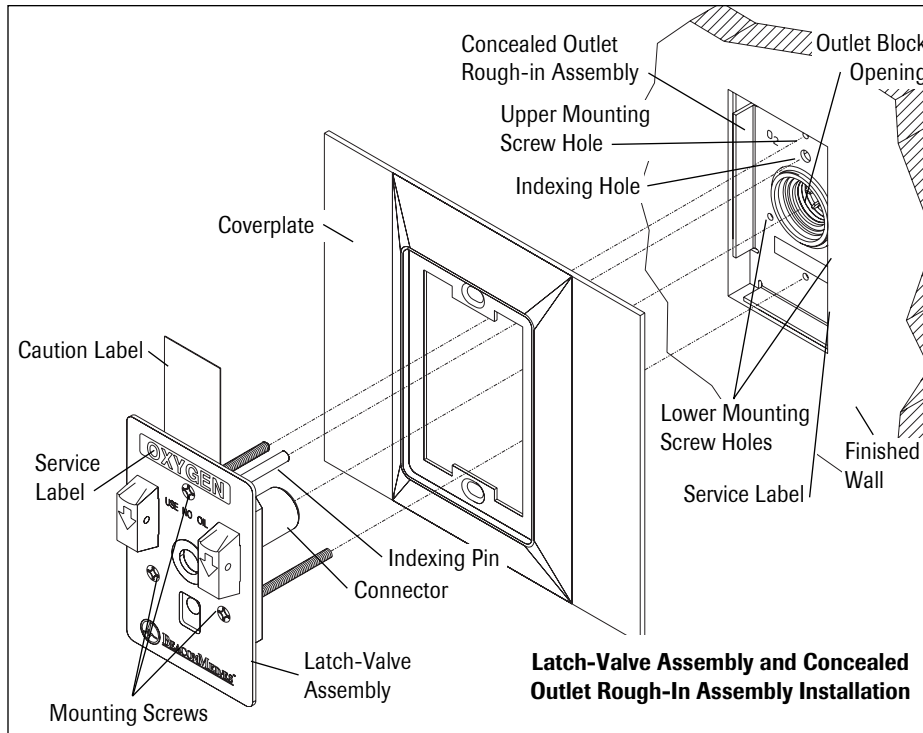

Figure 1

Installation in Console Outlet Rough-In Assemblies

NOTE:

It is the responsibility of the console manufacturer to incorporate the necessary design provisions for proper latch-valve assembly installation in the console. This instruction sheet provides information concerning latch-valve assembly installation in the outlet rough-in assembly. Additional installation information and hardware, if required, shall be provided by the console manufacturer.

1. Select the service indexed and labeled latch-valve assembly to match the correspondingly indexed and labeled console outlet rough-in assembly already installed. Remove the seal plug from vacuum or WAGD service rough-in assemblies, where applicable.
2. Installing the latch-valve assembly over the console fascia (Figure 2):
 - a. Install the console fascia according to the console manufacturer's instructions.
 - b. The upper and lower mounting screws along with a yellow caution label are held in place by rubber gaskets. **Read the caution label.**
 - c. Position the latch-valve assembly over the matching service indexed and labeled outlet rough-in assembly. Align the indexing pin on the latch-valve assembly with the indexing hole in the rough-in assembly. Push the connector on the latch-valve assembly into the outlet block opening in the rough-in assembly until the latch-valve assembly is flush against the fascia.

- d. Alternately tighten the latch-valve assembly mounting screws until the latch-valve assembly is held snug against the console fascia.

CAUTION:
Start the mounting screws by hand before using a power driver. Do not over-tighten the mounting screws. Doing so can distort the latch-valve and rough-in assemblies. Distortion may adversely affect the operation of the release mechanism.

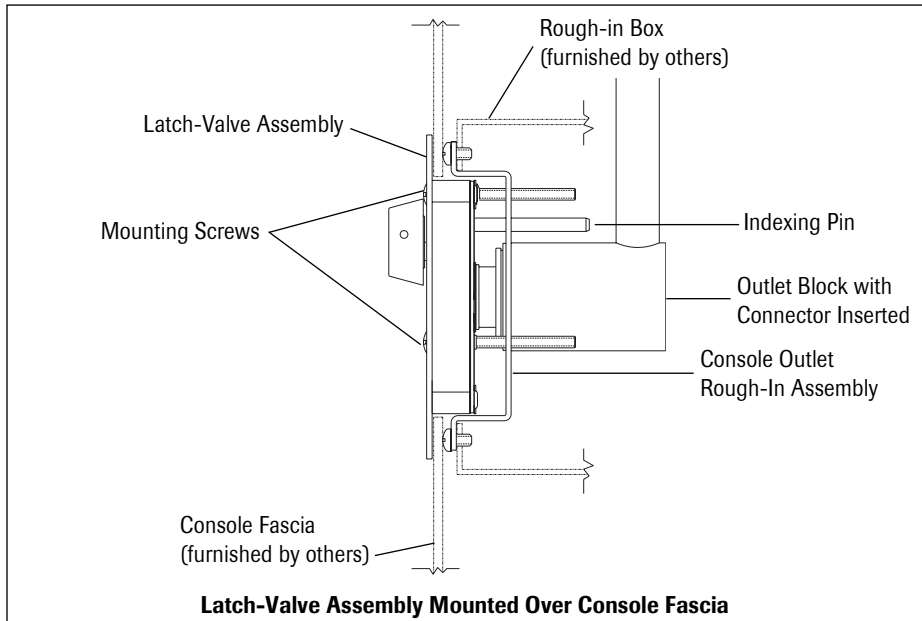

Figure 2

3. Installing the latch-valve assembly under the console fascia (Figure 3):
 - a. The upper and lower mounting screws along with a yellow caution label are held in place by rubber gaskets. **Read the caution label.**
 - b. Position the latch-valve assembly over the matching service indexed and labeled outlet rough-in assembly. Align the indexing pin on the latch-valve assembly with the indexing hole in the rough-in assembly. Push the connector on the latch-valve assembly into the outlet block opening in the rough-in assembly.
 - c. Alternately tighten the mounting screws only enough to allow installation of the console fascia.
 - d. Install the console fascia according to the console manufacturer's instructions.

- e. Back off the mounting screws, allowing the latch-valve assembly to move away from the rough-in assembly until it contacts the back of the console fascia. If the pipeline is pressurized, the latch-valve assembly will be assisted by the system pressure to move toward the back of the fascia. If the pipeline is not pressurized, or the latch-valve assembly is for vacuum or WAGD service, then the latch-valve assembly can be brought flush with the back of the console fascia by pulling out on it. After the latch-valve assembly is flush with the back of the console fascia, alternately tighten all screws until the screw heads are seated in their respective recesses in the faceplate of the latch-valve assembly. Further tightening will move the latch-valve assembly away from the fascia.

CAUTION:
Start the mounting screws by hand before using a power driver. Do not over-tighten the mounting screws. Doing so can distort the latch-valve and rough-in assemblies. Distortion may adversely affect the operation of the release mechanism.

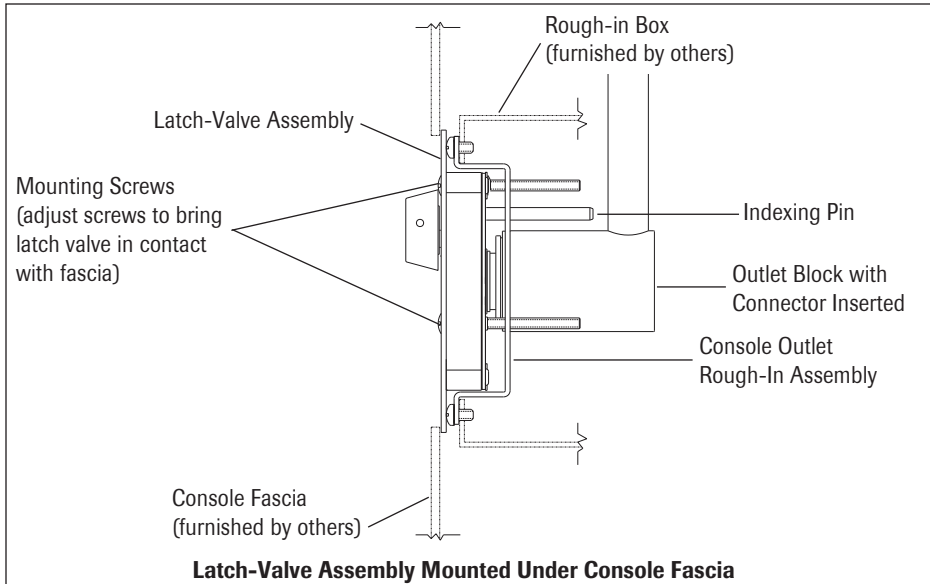

Figure 3

4. Verify that the latch-valve assembly meets all applicable codes or standards (e.g. NFPA 99 or CAN/CSA-Z305.1) after installation in the console outlet rough-in assembly.

