



Series B Medaes-Type Quick-Connect Latch-Valve Assembly

Installation Instructions

Part Numbers:
230940-00 through 230949-00

CAUTION:

Keep the latch-valve assembly free of oil, grease and other contaminants during installation.

Installation in Concealed Outlet Rough-In Assemblies

NOTE:

The latch-valve assembly and coverplate should be installed after the walls have been finished.

1. Select the service indexed and labeled latch-valve assembly to match the correspondingly indexed and labeled concealed outlet rough-in assembly already installed.
2. Remove the protective dust cover from the rough-in assembly. Remove the seal plug from vacuum or WAGD service rough-in assemblies, where applicable.
3. Installing the coverplate and latch-valve assembly (Figure 1):
 - a. The upper and lower mounting screws along with a yellow caution label are held in place by rubber gaskets. **Read the caution label.**
 - b. Orient the latch-valve assembly with the service label on top and place it inside the coverplate opening.
 - c. Position the combined latch-valve assembly and coverplate over the matching service indexed and labeled outlet rough-in assembly. Align the indexing pin on the latch-valve assembly with the indexing hole in the rough-in assembly. Push the connector on the latch-valve assembly into the outlet block opening in the rough-in assembly until the coverplate is flush against the finished wall.
 - d. Alternately tighten the latch-valve assembly mounting screws until the coverplate is held snug against the finished wall. Adjacent coverplates can be aligned by placing a straight edge along the bottom of all coverplates while tightening the screws.

CAUTION:

Do not overtighten the mounting screws. Doing so may distort the latch-valve assembly.

4. Verify that the latch-valve assembly meets all applicable codes or standards (e.g. NFPA 99 or CAN/CSA-Z305.1) after installation in the concealed outlet rough-in assembly.

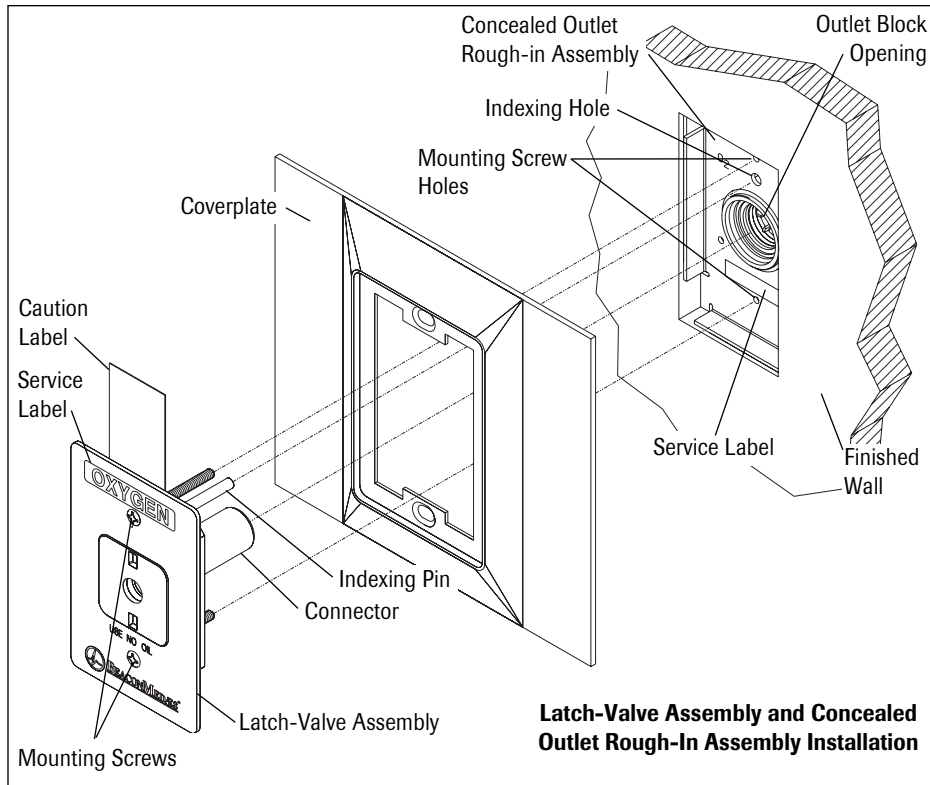

Figure 1

Installation in Console Outlet Rough-In Assemblies

NOTE:

It is the responsibility of the console manufacturer to incorporate the necessary design provisions for proper latch-valve assembly installation in the console. This instruction sheet provides information concerning latch-valve assembly installation in the outlet rough-in assembly. Additional installation information and hardware, if required, shall be provided by the console manufacturer.

1. Select the service indexed and labeled latch-valve assembly to match the correspondingly indexed and labeled console outlet rough-in assembly already installed. Remove the seal plug from vacuum or WAGD service rough-in assemblies, where applicable.
2. Installing the latch-valve assembly over the console fascia (Figure 2):
 - a. Install the console fascia according to the console manufacturer's instructions.
 - b. The upper and lower mounting screws along with a yellow caution label are held in place by rubber gaskets. **Read the caution label.**
 - c. Position the latch-valve assembly over the matching service indexed and labeled outlet rough-in assembly. Align the indexing pin on the latch-valve assembly with the indexing hole in the rough-in assembly. Push the connector on the latch-valve assembly into the outlet block opening in the rough-in assembly until the latch-valve assembly is flush against the fascia.

- d. Alternately tighten the mounting screws until the latch-valve assembly is held snug against the console fascia.

CAUTION:
Do not overtighten the mounting screws. Doing so may distort the latch-valve assembly.

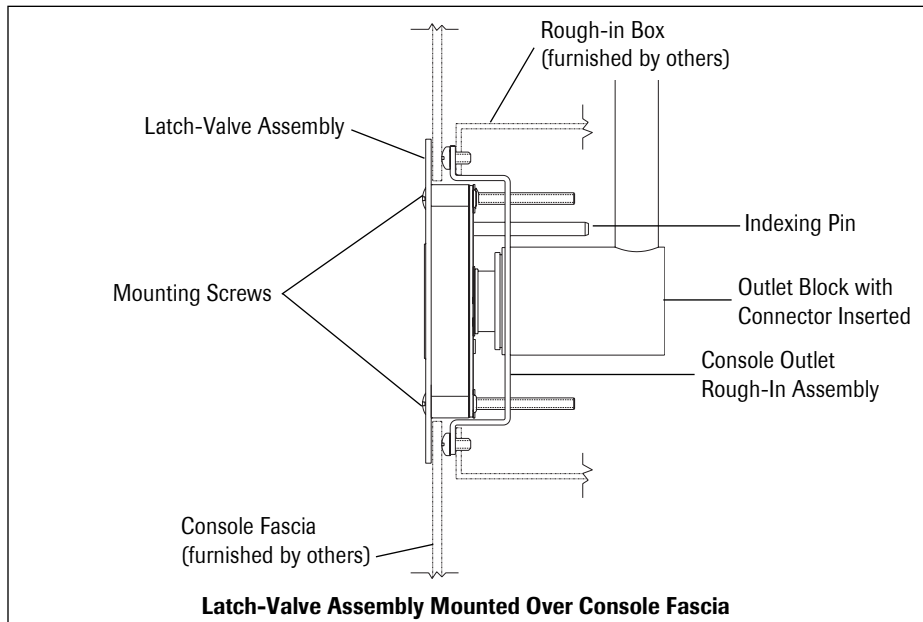

Figure 2

3. Installing the latch-valve assembly under the console fascia (Figure 3):
 - a. The upper and lower mounting screws along with a yellow caution label are held in place by rubber gaskets. **Read the caution label.**
 - b. Position the latch-valve assembly over the matching service indexed and labeled outlet rough-in assembly. Align the indexing pin on the latch-valve assembly with the indexing hole in the rough-in assembly. Push the connector on the latch-valve assembly into the outlet block opening in the rough-in assembly.
 - c. Alternately tighten the mounting screws only enough to allow installation of the console fascia.
 - d. Install the console fascia according to the console manufacturer's instructions.

- e. Back off the top mounting screws, allowing the latch-valve assembly to move away from the rough-in assembly until it contacts the back of the console fascia. If the pipeline is pressurized, the latch-valve assembly will be assisted by the system pressure to move toward the back of the fascia. If the pipeline is not pressurized, or the latch-valve assembly is for vacuum or WAGD service, then the latch-valve assembly can be brought flush with the back of the console fascia by pulling out on it. After the latch-valve assembly is flush with the back of the console fascia, tighten all screws until the screw heads are seated in their respective recesses in the faceplate of the latch-valve assembly. Further tightening will move the latch-valve assembly away from the fascia.

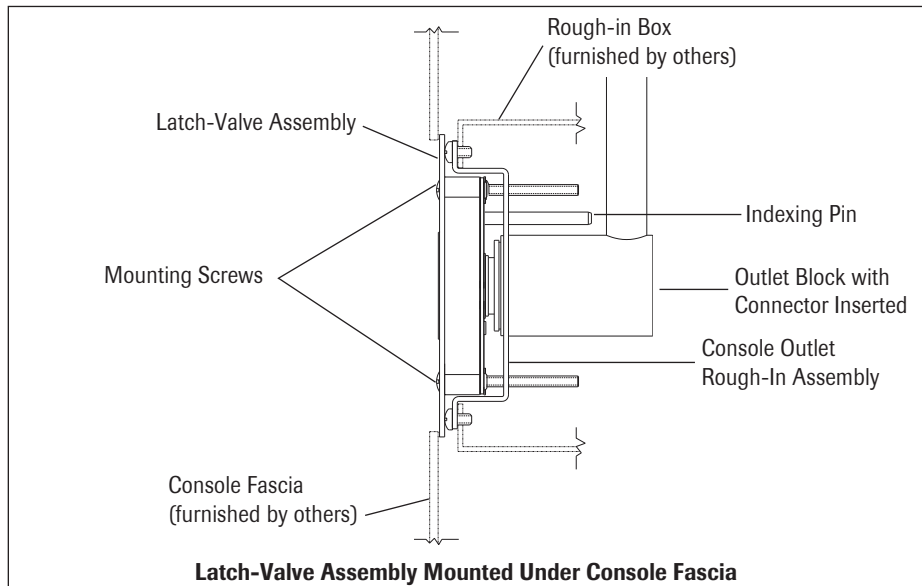

Figure 3

4. Verify that the latch-valve assembly meets all applicable codes or standards (e.g. NFPA 99 or CAN/CSA-Z305.1) after installation in the console outlet rough-in assembly.

