



Series B Diameter-Index Safety System Valve Assembly

Installation Instructions

Part Numbers:
230910-00 through 230922-00

CAUTION:

Keep the valve assembly free of oil, grease and other contaminants during installation.

Installation in Concealed Outlet Rough-In Assemblies

NOTE:

The valve assembly and coverplate should be installed after the walls have been finished.

1. Select the service indexed and labeled valve assembly to match the correspondingly indexed and labeled concealed outlet rough-in assembly already installed.
2. Remove the protective dust cover from the rough-in assembly. Remove the seal plug from vacuum or WAGD service rough-in assemblies, where applicable.
3. Installing the coverplate and valve assembly (Figure 1):
 - a. The upper and lower mounting screws along with a yellow caution label are held in place by rubber gaskets. **Read the caution label.**
 - b. Orient the valve assembly with the service label on top and place it inside the coverplate opening.
 - c. Position the combined valve assembly and coverplate over the matching service indexed and labeled outlet rough-in assembly. Align the indexing pin on the valve assembly with the indexing hole in the rough-in assembly. Push the connector on the valve assembly into the outlet block opening in the rough-in assembly until the coverplate is flush against the finished wall.
 - d. Alternately tighten the valve assembly mounting screws until the coverplate is held snug against the finished wall. Adjacent coverplates can be aligned by placing a straight edge along the bottom of all coverplates while tightening the screws.

CAUTION:

Do not overtighten the mounting screws. Doing so may distort the valve assembly.

4. Verify that the valve assembly meets all applicable codes or standards (e.g. NFPA 99 or CAN/CSA-Z305.1) after installation in the concealed outlet rough-in assembly.

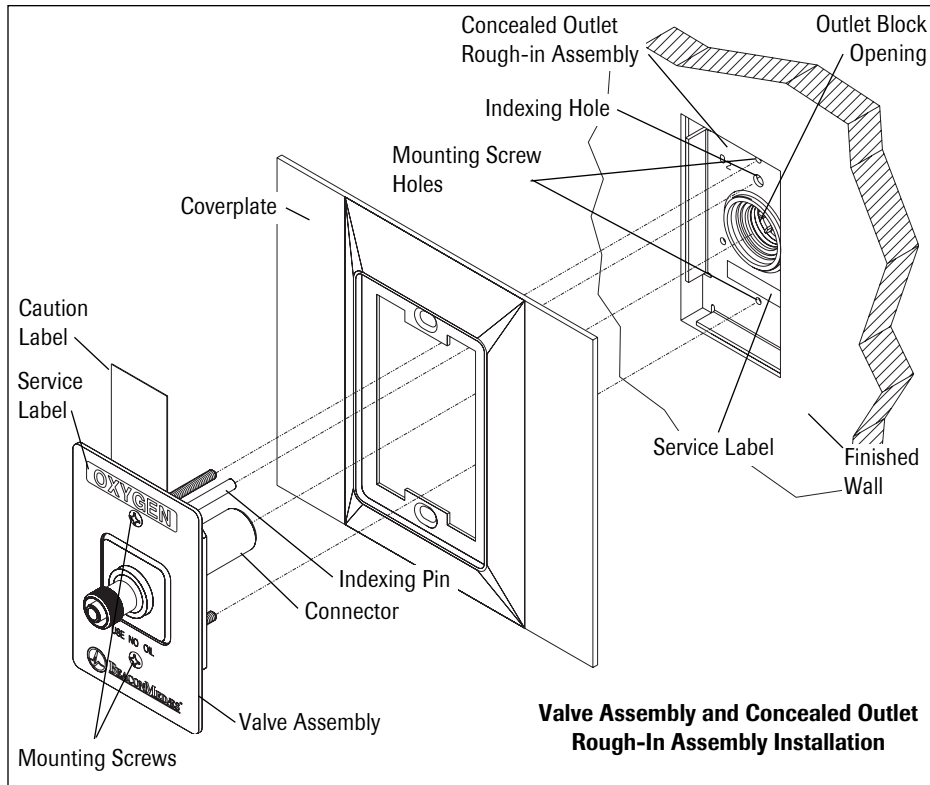

Figure 1

Installation in Console Outlet Rough-In Assemblies

NOTE:

It is the responsibility of the console manufacturer to incorporate the necessary design provisions for proper valve assembly installation in the console. This instruction sheet provides information concerning valve assembly installation in the outlet rough-in assembly. Additional installation information and hardware, if required, shall be provided by the console manufacturer.

1. Select the service indexed and labeled valve assembly to match the correspondingly indexed and labeled console outlet rough-in assembly already installed. Remove the seal plug from vacuum or WAGD service rough-in assemblies, where applicable.
2. Installing the valve assembly over the console fascia (Figure 2):
 - a. Install the console fascia according to the console manufacturer's instructions.
 - b. The upper and lower mounting screws along with a yellow caution label are held in place by rubber gaskets. **Read the caution label.**
 - c. Position the valve assembly over the matching service indexed and labeled outlet rough-in assembly. Align the indexing pin on the valve assembly with the indexing hole in the rough-in assembly. Push the connector on the valve assembly into the outlet block opening in the rough-in assembly until the valve assembly is flush against the fascia.

- d. Alternately tighten the mounting screws until the valve assembly is held snug against the console fascia.

CAUTION:

Do not overtighten the mounting screws. Doing so may distort the valve assembly.

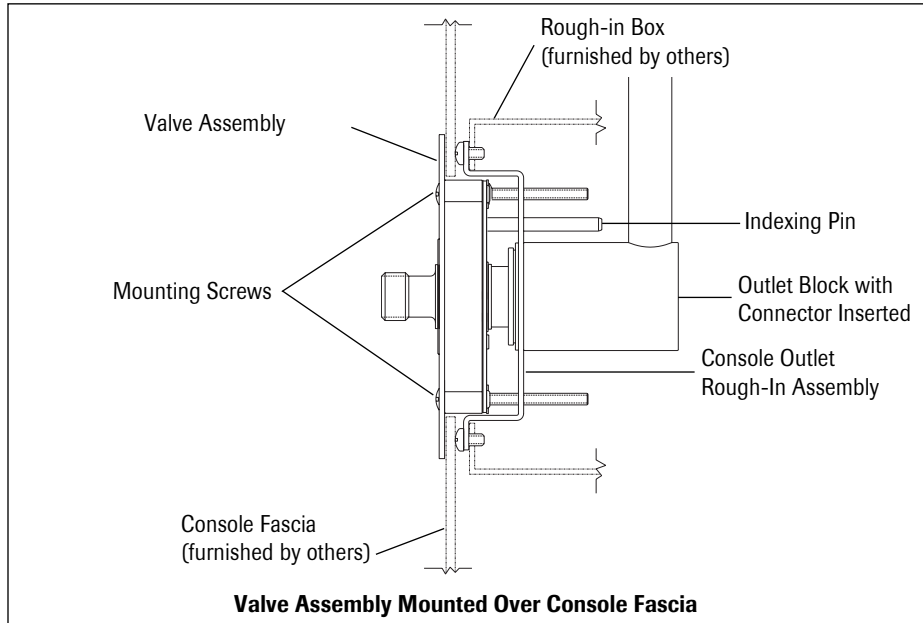

Figure 2

3. Installing the valve assembly under the console fascia (Figure 3):
 - a. The upper and lower mounting screws along with a yellow caution label are held in place by rubber gaskets. **Read the caution label.**
 - b. Position the valve assembly over the matching service indexed and labeled outlet rough-in assembly. Align the indexing pin on the valve assembly with the indexing hole in the rough-in assembly. Push the connector on the valve assembly into the outlet block opening in the rough-in assembly.
 - c. Alternately tighten the mounting screws only enough to allow installation of the console fascia.
 - d. Install the console fascia according to the console manufacturer's instructions.
 - e. Back off the top mounting screws, allowing the valve assembly to move away from the rough-in assembly until it contacts the back of the console fascia. If the pipeline is

pressurized, the valve assembly will be assisted by the system pressure to move toward the back of the fascia. If the pipeline is not pressurized, or the valve assembly is for vacuum or WAGD service, then the valve assembly can be brought flush with the back of the console fascia by pulling out on it. After the valve assembly is flush with the back of the console fascia, tighten all screws until the screw heads are seated in their respective recesses in the faceplate of the valve assembly. Further tightening will move the valve assembly away from the fascia.

4. Verify that the valve assembly meets all applicable codes or standards (e.g. NFPA 99 or CAN/CSA-Z305.1) after installation in the console outlet rough-in assembly.

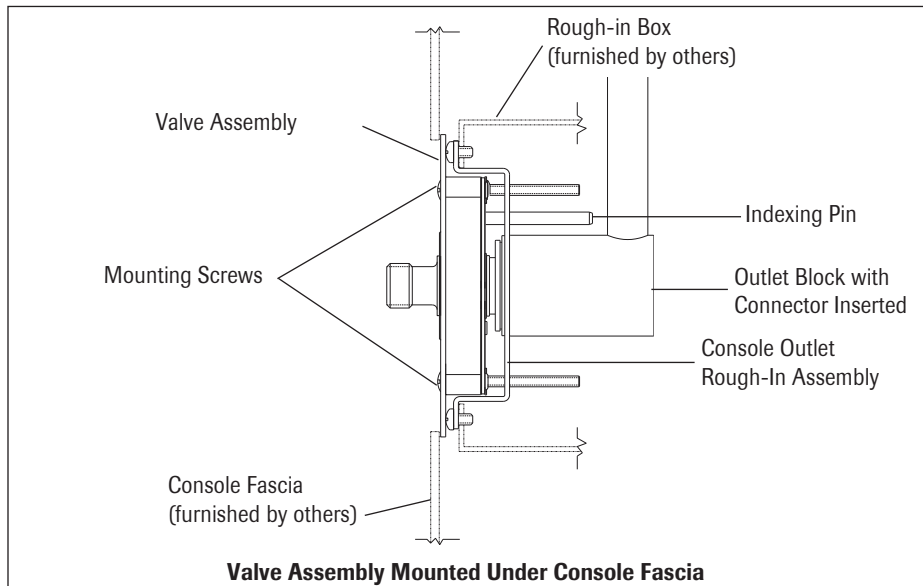

Figure 3

