

# Installation, Operation and Maintenance Instructions



## Lubricated Rotary Vane Medical Vacuum System

*Part number 4107 9000 96*

*Revision 08*

*January 19, 2024*



**BEACONMEDÆS<sup>®</sup>**

*Part of the Atlas Copco Group*





## Installation, Operation and Maintenance Manual

### 1.5 - 25 Hp Medical Lubricated Rotary Vane Vacuum System

(Not intended for use on dedicated WAGD applications as per NFPA 99 - 2005 edition)

This unit is purchased from: \_\_\_\_\_

Date purchased: \_\_\_\_\_

Model number: \_\_\_\_\_

Serial number: \_\_\_\_\_

Option(s) included: \_\_\_\_\_

Any information, service or spare parts requests should include the machine serial number and be directed to:

**BeaconMedæ**  
1059 Paragon Way  
Rock Hill, SC 29730

Telephone: (888) 463-3427  
Fax: (803) 817-5750

**BeaconMedæ reserves the right to make changes and improvements to update products sold previously without notice or obligation.**

*Part number 4107 9000 96*  
*Revision 08*  
*January 19, 2024*



## Table of Contents

### 1.0 General Information

- 1.1 Component Description
- 1.2 Electromagnetic Immunity

### 2.0 Installation

- 2.1 Inspection Upon Receiving
- 2.2 Handling
- 2.3 Location
- 2.4 Locations Above Sea Level
- 2.5 Electrical Requirements
- 2.6 Intake Piping
- 2.7 Exhaust Piping

### 3A.0 Start Up - TotalAlert 360 Controls

- 3A.1 Prestart-up
- 3A.2 Initial Start-up
- 3A.3 Initial Operation

### 3B.0 Start Up - Basic Controls

- 3B.1 Prestart-up
- 3B.2 Initial Start-up
- 3B.3 Initial Operation

### 4A.0 General Operation - TotalAlert 360 Controls

- 4A.1 Electrical Control Panel
- 4A.2 Tank Drains
- 4A.3 Emergency Shutdown / Alarms
- 4A.4 Backup Vacuum Switch Set Point Adjustments

### 4B.0 General Operation - Basic Controls

- 4B.1 Electrical Control Panel
- 4B.2 Tank Drains
- 4B.3 Emergency Shutdown / Alarms
- 4B.4 Vacuum Switch Set Point Adjustments

## Table of Contents (continued)

### 5.0 Troubleshooting

### 6.0 Maintenance

- 6.1 General Maintenance
- 6.2 Oil
- 6.3 Drip Leg and Filters
- 6.4 Bearings
- 6.5 General Inspections
- 6.6 Cleaning

### 7.0 Replacement / Maintenance Parts

- 7.1 Service Kits for Lubricated Vane Systems
- 7.2 Retrofit Kits for HEPA Filters
- 7.3 PPE Kit for Filter Service

### 8.0 Maintenance Record

### Appendix A: TotalAlert 360 Control System

- A.1 Board Configurations
- A.2 Manual Override
- A.3 10.1" Display Controller
- A.4 User Access
- A.5 BACnet
- A.6 MyMedGas

## Safety Precautions

The operator should carefully read the entire contents of this manual before installing, wiring, starting, operating, adjusting and maintaining the system.

The operator is expected to use common-sense safety precautions, good workmanship practices and follow any related local safety precautions.

In addition:

- **Before starting any installation or maintenance procedures, disconnect all power to the package.**
- All electrical procedures must be in compliance with all national, state, and local codes and requirements.
- A certified electrician should connect all wiring.
- Refer to the electrical wiring diagram provided with the unit before starting any installation or maintenance work.
- Release all vacuum from the affected components before removing, loosening, or servicing any covers, guards, fittings, connections, or other devices.
- Notify appropriate hospital personnel if repairs or maintenance will affect available vacuum levels.
- Prior to using the LifeLine® Lubricated Rotary Vane Medical Vacuum System, the medical facility must have a Certifier perform all installation tests as specified in NFPA 99. The medical facility is also responsible for ensuring that the medical vacuum meets the minimum requirements as specified in NFPA 99.
- This is a high speed, rotating piece of machinery. Do not attempt to service any part while machine is in operation.
- To prevent automatic starting, disconnect all electrical power before performing any maintenance.
- Do not operate unit without guards, shields or screens in place.
- Make sure that all loose articles, packing material, and tools are clear of the package.
- Check all safety devices periodically for proper operation.
- The “Manual” mode of operation should only be used for emergencies such as a printed circuit board malfunction and should not be used for normal operation.
- Electrical service must be the same as specified on the control panel nameplate or damage to the equipment may occur.
- Vibration during shipment can loosen electrical terminals, fuse inserts, and mechanical connections. Tighten all electrical connections prior to energizing the control panel.





## 1.0 General Information

### 1.1 Component Description

**NOTE:** The features listed in this section are standard for NFPA 99 medical vacuum systems. In the case of special system configurations, these features may or may not be included with the system.

#### System Design

The LifeLine® Lubricated Rotary Vane Medical vacuum package is fully compliant with NFPA 99. Designed and manufactured with ISO 13485 processes, each system is completely tested before shipment and includes:

- Oil-sealed rotary vane vacuum pumps with motors
- Integral pre-wired control panel
- Air receiver with full-size three-valve bypass system sized for appropriate demand

#### Vacuum Pump

Each pump is a direct driven, oil-sealed rotary vane vacuum pump, with an end (ultimate) vacuum of 29.3" Hg. Each pump is completely air-cooled with no water requirements. Each pump contains:

- Integral, fully recirculating oil supply to provide lubrication
- An automotive-type, spin-on oil filter for oil filtration
- High-discharge temperature switch
- Oil drain valve assembly with temperature gauge

The oil separation system is integral and consists of the following:

- No less than three stages of internally installed oil and smoke eliminators through which the exhaust gas stream must pass

- Bulk separation, oil mist elimination, and smoke elimination
- Capability to remove 99.9+ percent of all oil and smoke particles from the exhaust gas stream

Each vacuum pump includes the following:

- Built-in, anti-suck-back valve mounted at the pump inlet
- Three non-metallic, non-asbestos vanes, each having a minimum life of 30,000 hours
- Mounting on vibration isolators
- Flexible connector and isolation valve

#### Vacuum Pump Drive

The pump shall be direct driven. Torque is transmitted from the motor to the pump through a shaft coupling.

#### Vacuum Pump Motor

Motors are continuous duty, NEMA rated, C-face, foot-mounted, TEFC, suitable for 230/460 or 208V, 60 hertz, 3-phase electrical service and 380V, 50 hertz, 3-phase electrical service.

#### Vacuum Filtration per NFPA 99

A HEPA inlet air filter, 0.3 micron, 99.97% efficiency, is mounted before each vacuum pump. A clear, glass collection canister is mounted below each HEPA filter, with quarter turn valve to isolate canister from filter during service. The inlet filter canister contains a bleed valve to relieve vacuum before servicing.

#### Intake Piping

Each vacuum pump has a factory piped intake with integral flex connector, isolation valve, and check valve. Interconnecting piping consists of powder-coated steel tubing and flanges.

#### Vacuum Receiver

The vacuum receiver is ASME Code stamped, and rated for a minimum 150 PSIG design pressure.

## 1.0 General Information

The receiver has a full-size three-valve bypass system to allow for draining of the receiver without interrupting the vacuum service. A manual drain is provided on the receiver.

### **Exhaust Piping**

Each vacuum pump is factory piped with integral flex connector to an exhaust manifold with a drip leg and ball valve for condensate drain. Interconnecting piping consists of powdercoated steel tubing and flanges.

### **TotalAlert 360 Control System**

The TotalAlert 360 control system is U.L. labeled. The control system provides automatic lead/lag sequencing and automatic alternation of all vacuum pumps based on first-on/first-off principle with provision for simultaneous operation if required. Automatic activation of reserve unit, if required, will activate an audible alarm as well as a visual alarm on the display screen. Additional components include:

- NEMA 12 control panel enclosure
- Circuit breaker disconnects for each motor with external operators
- Full voltage motor starters with overload protection
- 24V control circuit
- 65kAIC SCCR rating for control cabinet

The touch screen controls feature a 10" color, high resolution screen. Screen displays and functions include:

- Easy to read system vacuum level
- Status of all units (Running, Available, Off, next to Run)
- Trend graphs for vacuum level and units running
- Run time hour meters for each unit

- Visual/audible alarm indications with isolated contacts for all standard remote alarms
- Event log recording alarms and system activity
- Service alerts
- Event log recording service warnings and service history
- Integral cellular connectivity to MyMedGas, allowing electronic notifications of alarms and warnings
- Daily rounds uploadable to MyMedGas
- BTL listed, BACnet/IP communication

## 1.2 Electromagnetic Immunity

**Note:** This section applicable to Lubricated Rotary Vane Medical Vacuum Systems with the TotalAlert 360 electronic control system.

### **EN 61000-6-2**

Medical Electrical Equipment needs special precautions regarding EMC and needs to be installed and put into service according to the EMC information provided in this manual.

Portable and mobile RF communications equipment can affect Medical Electrical Equipment.

The use of accessories, transducers, and cables other than those specified by the manufacturer, may result in decreased immunity of the TotalAlert 360 control system.

The TotalAlert 360 control system should not be used adjacent to other equipment. If adjacent use is necessary, the TotalAlert 360 control system should be observed to verify normal operation in the configuration in which it will be used.


# 1.0 General Information

## EN 61000-6-2 (Cont.)

Guidance and manufacturer's declaration - electromagnetic immunity			
The TotalAlert 360 control system is intended for use in the electromagnetic environment specified below. The customer or the user of the TotalAlert 360 control system should assure that it is used in such an environment.			
Immunity test	IEC 60601 test level	Compliance level	Electromagnetic environment - guidance
Electrostatic Discharge (ESD) IEC 61000-4-2	±6 kV contact ±8 kV air	±6 kV contact ±8 kV air	Floors should be wood, concrete, metal or ceramic tile. If floors are covered with synthetic material, the relative humidity should be at least 30 %.
Electrical fast transient/burst IEC 61000-4-4	±2 kV for power supply lines ±1 kV for input/output lines	±2 kV for power supply lines ±1 kV for input/output lines	Mains power quality should be that of a typical commercial or hospital environment.
Surge IEC 61000-4-5	±1 kV differential mode ±2 kV common mode	±1 kV differential mode ±2 kV common mode	Mains power quality should be that of a typical commercial or hospital environment
Voltage dips, short Interruptions and voltage variations on power supply input lines IEC 61000-4-34	<5 % $U_T$ (>95 % dip in $U_T$ ) for 0,5 cycle <40 % $U_T$ (>60 % dip in $U_T$ ) for 5 cycles <70 % $U_T$ (>30 % dip in $U_T$ ) for 25 cycles <5 % $U_T$ (>95 % dip in $U_T$ ) for 5 sec	<5 % $U_T$ (>95 % dip in $U_T$ ) for 0,5 cycle <40 % $U_T$ (>60 % dip in $U_T$ ) for 5 cycles <70 % $U_T$ (>30 % dip in $U_T$ ) for 25 cycles <5 % $U_T$ (>95 % dip in $U_T$ ) for 5 sec	Mains power quality should be that of a typical commercial or hospital environment. If the user of the TotalAlert 360 control system requires continued operation during power mains interruptions, it is recommended that the system be installed on an emergency power service.
Power frequency (50/60 Hz) magnetic field IEC 61000-4-8	3 A/m	3 A/m	Power frequency magnetic fields should be at levels characteristic of a typical location in a typical commercial or hospital environment.
NOTE: $U_T$ is the a.c. mains voltage prior to application of the test level.			

# 1.0 General Information

## EN 61000-6-2 (Cont.)

Guidance and manufacturer's declaration - electromagnetic immunity			
The TotalAlert 360 control system is intended for use in the electromagnetic environment specified below. The customer or the user of the TotalAlert 360 control system should assure that it is used in such an environment.			
Immunity test	IEC 60601 test level	Compliance level	Electromagnetic environment - guidance
Conducted RF IEC 61000-4-6	3 Vrms 150 kHz to 80 MHz	3 Vrms	<p>Portable and mobile RF communications equipment should be used no closer to any part of the TotalAlert 360 control system, including cables, than the recommended separation distance calculated from the equation applicable to the frequency of the transmitter.</p> <p>Recommended separation distance</p> $d = 1,2\sqrt{P}$ <p><math>d = 1,2\sqrt{P}</math>    80 MHz to 800 MHz</p> <p><math>d = 2,3\sqrt{P}</math>    800 MHz to 2,5 GHz</p> <p>where <math>P</math> is the maximum output power rating of the transmitter in watts (W) according to the transmitter manufacturer and <math>d</math> is the recommended separation distance in metres (m).</p>
Radiated RF IEC 61000-4-3	3 V/m 80 MHz to 2,5 GHz	3 V/m	<p>Field strengths from fixed RF transmitters, as determined by an electromagnetic site survey,<sup>a</sup> should be less than the compliance level in each frequency range.<sup>b</sup></p> <p>Interference may occur in the vicinity of equipment marked with the following symbol:</p> 
NOTE 1 At 80 MHz and 800 MHz, the higher frequency range applies.			
NOTE 2 These guidelines may not apply in all situations. Electromagnetic propagation is affected by absorption and reflection from structures, objects and people.			
<p><sup>a</sup> Field strengths from fixed transmitters, such as base stations for radio (cellular/cordless) telephones and land mobile radios, amateur radio, AM and FM radio broadcast and TV broadcast cannot be predicted theoretically with accuracy. To assess the electromagnetic environment due to fixed RF transmitters, an electromagnetic site survey should be considered. If the measured field strength in the location in which the TotalAlert 360 control system is used exceeds the applicable RF compliance level above, the TotalAlert 360 control system should be observed to verify normal operation. If abnormal performance is observed, additional measures may be necessary, such as reorienting or relocating the TotalAlert 360 control system.</p> <p><sup>b</sup> Over the frequency range 150 kHz to 80 MHz, field strengths should be less than 3 V/m.</p>			

## 2.0 Installation

### 2.1 Inspection Upon Receiving

The condition of the **LifeLine**<sup>®</sup> Lubricated Rotary Vane Medical Vacuum System should be carefully inspected upon delivery. Any indication of damage by the carrier should be noted on the delivery receipt, especially if the system will not be immediately uncrated and installed. **BeaconMedæx** ships all systems F.O.B. factory; therefore, damage is the responsibility of the carrier, and all claims must be made with them. Lubricated Vane systems may remain in their shipping containers until ready for installation. If **LifeLine**<sup>®</sup> Lubricated Vane systems are to be stored prior to installation, they must be protected from the elements to prevent rust and deterioration.

**DO NOT REMOVE** the protective covers from the inlet and discharge connection ports of the unit until they are ready for connecting to the hospital's pipeline distribution system.

### 2.2 Handling

**WARNING:**  
**USE APPROPRIATE LOAD RATED LIFTING EQUIPMENT AND OBSERVE SAFE LIFTING PROCEDURES DURING ALL MOVES.**

The vacuum package can be moved with either a forklift or dollies. Keep all packing in place during installation to minimize damage. Walk along the route the unit must travel and note dimensions of doorways and low ceilings.

**Most Single Point Connection systems can be separated to fit through 36" doorways** (15 Hp through 25 Hp skid bases measure 43"). If separating bases, carefully label all removed electrical connections for easier re-assembly at the final destination.

Modular systems are shipped as separate units to facilitate a variety of installations. Most modular and tank mount units are designed to fit through

a standard 36" doorway, though some receiver modules may need to be tipped slightly (15 Hp through 25 Hp skid bases measure 43"). Some interconnecting piping and wiring between modules may be necessary on modular systems only.

### 2.3 Location

The **LifeLine**<sup>®</sup> Lubricated Rotary Vane Medical Vacuum system should be installed indoors in a clean, well-ventilated environment. Areas of excessive dust, dirt or other air-borne particulate should be avoided.

Refer to the diagrams supplied with your system for dimensional, wiring and installation information.

Place units to ensure high visibility of indicators and gauges and for performing maintenance on the system. Refer to your installation diagram. If you do not have one, please contact **BeaconMedæx Technical Support** at 888-4-MEDGAS.

Certain considerations should be given to the placement of the system. Install the package in a location that is flat, level, and will support its weight. Clearance between the unit and adjacent walls should be no less than 24" to ensure sufficient airflow for cooling. There should be a minimum of three feet of clearance in front of the control panel for safe operation and maintenance. A vertical distance of 24" is required above the modules for ventilation and maintenance.

**No special foundation is required.** However, all units must be securely bolted using all mounting holes provided. If a raised concrete pad is used, the module bases must not overhang the concrete base. A method to drain away moisture is necessary.

Adequate ventilation is required. The pumps are air-cooled. Therefore, ambient temperature should be between 40°F and 105°F (if the maximum ambient exceeds 105°F, contact factory for special instructions). The system should be located as close as possible to the point of usage

## 2.0 Installation

to prevent excessive loss of operating vacuum due to pressure drop.

When selecting the location for the system, consider the requirements for service, such as cleaning, changing filters, and changing oil.

### 2.4 Locations Above Sea Level

All vacuum pumps above sea level have reduced flow and should be de-rated. After determining the correct flow needed for the medical vacuum system, multiply this number by the adjustment factor located in Table 2.4.1. After determining the new flow required, use this number to size the medical vacuum system.

Table 2.4.1 Altitude Adjustment Factor

Altitude (ft)	Normal Barometric Pressure (inches HG)	Multiplier Used for Required SCFM
0	29.92	1.00
500	29.39	1.02
1,000	28.86	1.04
1,500	28.33	1.06
2,000	27.82	1.08
2,500	27.32	1.10
3,000	26.82	1.12
3,500	26.33	1.14
4,000	25.84	1.16
5,000	24.90	1.20
6,000	23.98	1.25
7,000	23.09	1.30
8,000	22.23	1.35
9,000	21.39	1.40
10,000	20.58	1.45

## 2.5 Electrical Requirements

**WARNING:**

**BE SURE THAT ALL POWER IS TURNED OFF PRIOR TO PERFORMING ANY WORK ON THE ELECTRICAL PANEL!**

Refer to the electrical diagram provided with the unit before starting any installation or maintenance work.

Do not operate vacuum pump on a voltage other than the voltage specified on the control panel nameplate.

All customer wiring should be in compliance with the National Electrical Code and any other applicable state or local codes.

Refer to the wiring diagram(s) that came with the vacuum pump system for pertinent wiring connections.

Electrical power for the medical system must be supplied from the emergency life support circuit.

Check the control voltage, phase, and amp ratings before starting the electrical installation, and make sure the voltage supplied by the hospital is the same. The wire size should be able to handle peak motor amp load of all operating units. Refer to the vacuum pump system full load amperes on the wiring diagram.

Check all electrical connections within the vacuum system that may have loosened during shipment.

Qualified electricians only should make power connections to the control panel and any interconnecting wiring. The control panel has openings for electrical and alarm/data connections. **Do not drill additional holes in the control panel as this may void the system warranty.** See Figure 2.5.1 for opening locations.



## 2.0 Installation



**Figure 2.5.1 Electrical/Alarm/Data/USB Openings**

Ensure that the emergency generation system electrical supply is consistent with the vacuum system’s requirements.

The electrical controls for the system were wired at the factory and were fully tested.

Three-phase power supplied from emergency generator(s) must match that of the normal supply to allow for correct direction of the motor rotation at all times.

**NOTE:** It may be necessary to switch two of the leads when performing start-up, if the pump rotation is in the wrong direction.

## 2.6 Intake Piping

Before connecting any piping, the plastic thread protector installed in the connection port must be removed. We recommend that the main vacuum line to the receiver should not be reduced below that provided on the receiver. Long piping runs may need to be increased in size to minimize pressure drop. Improper line sizing may result in a loss of capacity. Ideally, piping should be constructed using long radius elbows and a minimum number of turns.

All secondary lines should be taken from the top or side of the main line to prevent any accumulated moisture from draining towards the pumps. All lines should slope away from the pumps. Any low points in the piping should be equipped with pipe drains to remove accumulated moisture.

All intake vacuum lines must be piped in accordance with NFPA 99. All pipe must be either seamless copper tubing or other corrosion-resistant metallic tubing, as detailed in NFPA 99.

## 2.7 Exhaust Piping

The exhaust line must be piped outside of the building in accordance with NFPA 99. To ensure that no restriction of airflow will occur, size the piping according to Table 2.7.1. All pipe must be either seamless copper tubing or other corrosion-resistant metallic tubing as detailed in NFPA 99. A flexible connector must be installed on each exhaust port of the vacuum pump before connecting to the main exhaust line leading outdoors. Additionally, a drip leg must be installed at each exhaust port connection to allow for the draining of any accumulated moisture (Refer to the installation schematics for more details). The outside pipe must be turned down and screened to prevent contamination.

## 2.0 Installation

**WARNING:**

**THE VACUUM EXHAUST VENT MUST BE LOCATED AWAY FROM MEDICAL AIR INTAKES, DOORS, AND OPENINGS IN THE BUILDINGS TO MINIMIZE POSSIBLE CONTAMINATION TO THE FACILITY, IN ACCORDANCE WITH NFPA 99.**

Table 2.7.1 Exhaust Pipe Length

	LifeLine Units	Pump Connection	System Exhaust Pipe Length (ft) - See Notes											
			25	50	75	100	150	200	250	300	350	400	450	500
SIMPLEX	1.5 Hp	1.25	1.25	1.25	1.25	1.25	1.25	1.25	1.25	1.25	1.25	1.25	1.25	1.25
	2 Hp	1.25	1.25	1.25	1.25	1.25	1.25	1.25	1.25	1.25	1.25	1.5	1.5	1.5
	3 Hp	1.25	1.5	1.5	1.5	1.5	1.5	1.5	1.5	1.5	1.5	1.5	2	2
	5 Hp <sup>1</sup>	1.25	1.5	1.5	1.5	1.5	1.5	2	2	2	2	2	2	2
	5 Hp <sup>2</sup>	2	2	2	2	2	2	2	2	2	2	3	3	3
	7.5 Hp	2	2	2	2	2	2	2	3	3	3	3	3	3
	10 Hp	2	2	2	2	3	3	3	3	3	3	3	3	3
	15 Hp	3	3	3	3	3	3	3	3	3	4	4	4	4
	20 Hp	3	3	3	3	3	3	3	3	4	4	4	4	4
	25 Hp	3	3	3	3	3	3	4	4	4	4	4	4	4
DUPLEX	1.5 Hp	1.25	1.25	1.25	1.25	1.25	1.25	1.25	1.5	1.5	1.5	1.5	1.5	1.5
	2 Hp	1.25	1.5	1.5	1.5	1.5	1.5	1.5	2	2	2	2	2	2
	3 Hp	1.25	1.5	1.5	1.5	1.5	2	2	2	2	2	2	3	3
	5 Hp <sup>1</sup>	1.25	2	2	2	2	2	3	3	3	3	3	3	3
	5 Hp <sup>2</sup>	2	2	2	2	3	3	3	3	3	3	3	3	3
	7.5 Hp	2	3	3	3	3	3	3	3	3	3	3	4	4
	10 Hp	2	3	3	3	3	3	4	4	4	4	4	4	4
	15 Hp	3	3	3	4	4	4	4	4	4	4	4	4	5
	20 Hp	3	4	4	4	4	4	4	4	5	5	5	5	5
	25 Hp	3	4	4	4	4	4	5	5	5	5	5	5	5
TRIPLEX	5 Hp <sup>2</sup>	2	3	3	3	3	3	3	3	3	4	4	4	4
	7.5 Hp	2	3	3	3	3	3	4	4	4	4	4	4	4
	10 Hp	2	4	4	4	4	4	4	4	4	4	5	5	5
	15 Hp	3	4	4	4	4	4	5	5	5	5	5	5	5
	20 Hp	3	5	5	5	5	5	5	5	5	5	6	6	6
	25 Hp	3	5	5	5	5	5	5	6	6	6	6	6	6



## 2.0 Installation

	LifeLine Units	Pump Connection	System Exhaust Pipe Length (ft) - See Notes											
			25	50	75	100	150	200	250	300	350	400	450	500
QUADRUPLIX	5 Hp <sup>2</sup>	2	3	3	3	3	3	4	4	4	4	4	4	4
	7.5 Hp	2	3	3	3	3	4	4	4	4	4	4	5	5
	10 Hp	2	4	4	4	4	4	4	5	5	5	5	5	5
	15 Hp	3	5	5	5	5	5	5	5	5	6	6	6	6
	20 Hp	3	6	6	6	6	6	6	6	6	6	6	6	6
	25 Hp	3	6	6	6	6	6	6	6	6	8	8	8	8

**Notes:**

- 5 Hp pump model RC0101 and RA0100. Incorporated into horizontal tankmount system designs.
- 5 Hp pump model RC0155 and RA0155. Incorporated into basemount system designs.
- All pipe sizes are based on the following: copper pipe (Type L), 14.7 psia.
- The minimum pipe size must be maintained for the total length of the exhaust pipe. Use next larger size pipe in the event the minimum size is not available.
- When determining the total pipe length, add all the straight lengths of pipe together in addition to the number of elbows times the effective pipe length for that pipe size. (See the following table and example.)

**Table 2.7.2 Pipe Length for 90° Elbow**

Effective Pipe Length Equivalent to each 90 degree Elbow										
Pipe Size (in.)	1.25	1.50	2.00	2.50	3.00	3.50	4.00	5.00	6.00	8.00
Eff. Pipe Length (ft)	3.4	4.0	4.9	6.4	7.9	9.4	10.0	11.9	13.2	14.5

**Example:**

Select the pipe size for a Triplex 7.5 HP with 130 feet of straight pipe and six elbows:

- Select the pipe size of 3” diameter for 130 feet of straight pipe.
- Determine the eff. pipe length for an elbow of 3” dia. (EPL= 7.9 ft / elbow).
- Calculate the SYSTEM PIPE LENGTH {SPL (3.0” D) = 130 + (6 x 7.9) = 177.4 ft}
- Check this SYSTEM PIPE LENGTH to see if it exceeds the minimum pipe size. In this case it does, select the next larger pipe size from the table (D = 4”).
- To double-check the pipe size, recalculate the SPL with the new diameter. SPL (D = 4”) = 130 + (6 x 10.0) = 190 ft. This is in the allowable range.



## 3A.0 Start Up - TotalAlert 360 Controls

**Note:** This section applicable to Lubricated Rotary Vane Medical Vacuum Systems with the TotalAlert 360 electronic control system.

### 3A.1 Prestart-up

The contractor should notify **BeaconMedæx** two weeks prior to start-up date to schedule an appointment for an authorized technician to review the installation prior to start-up.

**CAUTION:** Failure to install the unit properly and have an authorized technician from **BeaconMedæx** start-up the system can void the manufacturer's warranties.

**WARNING:**

**Prior to putting the LifeLine® Lubricated Rotary Vane Medical Vacuum system into use, the medical facility must have a Certifier perform all installation tests as specified in NFPA 99. The medical facility is also responsible for ensuring that the Medical Vacuum meets the minimum requirements for Medical Vacuum as specified in NFPA 99.**

Prestart-up and start-up procedures should be performed for a new installation or when major maintenance has been performed.

**WARNING:**

**Have more than one person on hand during prestart-up and start-up procedures to ensure safety and to facilitate certain checks.**

The main power source to the control panel should be OFF for the duration of the visual inspection.

Ensure that the equipment is installed on a solid level surface. Walk around the system to ensure that there is enough clearance on all sides to perform operational checks/actions and maintenance. The temperature of the area containing the modules

should be approximately 70°F (21.1°C) with a minimum ambient temperature of 40°F (4.4°C) and a maximum ambient temperature of 105°F (40°C).

- Check the intake piping for proper size and connection to the vacuum modules.
- Check all piping system joints that might have come loose during shipment and installation to ensure they are tight.
- Check the air receiver, controls, and pumps for damage.
- Check the drain valve on the air receiver.
- Check all valves for full open and full close travel. Ensure that the system's valves are positioned for proper operation. (Refer to labeling on valve handles)
- **Remove all packing material from the unit.**
- Check the electrical connections to the control cabinet.
- Verify electrical service. Before starting the system, check to see that voltage, amperage, and wire size are appropriate.

**CAUTION:** Electrical service must be as specified or damage to equipment may occur.

**WARNING:**

**To prevent electrical shock, ensure that ALL electrical power to the system is OFF, including the disconnect switches on the control panel. The facility's supply circuit breaker should also be locked out.**

- Open the electrical cabinet by loosening the fasteners on the front.

### 3A.0 Start Up - TotalAlert 360 Controls

**CAUTION:** Vibration during shipment and installation can loosen electrical terminals, fuse inserts, and mechanical connections. Tighten as necessary.

- Check the electrical cabinet for any broken components.
- Check that all motor starter connections are tight and that there are no loose objects such as terminal lugs, screws, nuts, etc., in the cabinet.

wiring diagram for your system to confirm which boards are unit controller boards.

Check all voltages supplied to the LifeLine® system to ensure they are the required value and phases needed by the control panel.

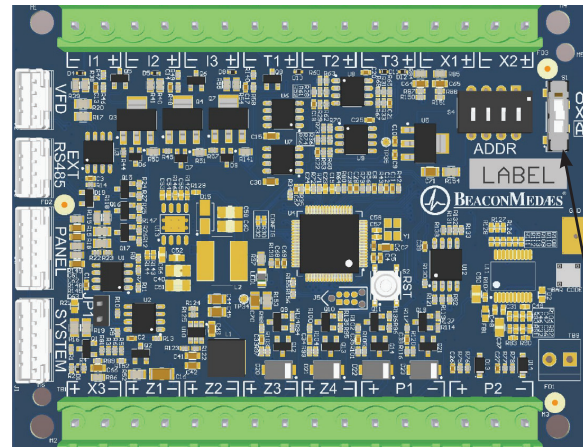
Apply power to the system and turn the disconnect switches to “On”.

### 3A.2 Initial Start-up

**CAUTION:** Complete the prestart-up procedure before continuing with the initial start-up procedure

**WARNING:**

**To prevent electrical shock, ensure that ALL electrical power to the system is OFF, including the disconnect switches. The facility’s supply circuit breaker should also be locked out.**



Manual Override Switch  
 O - On Manual  
 X - Off  
 A - Automatic

Figure 3A.2.2.1 Unit PCB Override Switch

#### 3A.2.1 Lubrication

The pumps are oil lubricated. The lubricating oil can be put into the pump at the oil filler port of the oil separator housing, observing the “MAX” and “MIN” position at the oil level sight glass. (For recommended oil type, refer to Section 6.1.) After filling, make sure the oil filler port is closed.

Prior to actual operation, the pumps must be checked for correct rotation.

All LifeLine® lubricated vacuum pumps are shipped with the required amount of oil for start-up. The systems are shipped with separate oil containers, which must be added before start-up.

Inside the control cabinet, switch one of the unit printed circuit boards from the manual override “Off” position to the bottom position, the default “Automatic” mode. Navigate to the Units screen by pressing on either of the unit status boxes on the main screen, see Figure 3A.2.2.2 Make sure the unit mode on the display is “Off”, see Figure 3A.2.2.3.

#### 3A.2.2 Unit Rotation

Inside the control panel, make sure that all unit printed circuit boards are set to the manual override “Off” position. This is indicated by the middle position “X” on the three-position sliding switch as shown in Figure 3A.2.2.1. Refer to the

Check for correct direction of rotation of each pump by pressing the “Rotate” button on touchscreen display (found in the Units Rotation section of the Service screen) and observing rotation. See Figure 3A.2.2.4. The mode for each compressor must be in the Off Position for the Rotation to function.

### 3A.0 Start Up - TotalAlert 360 Controls

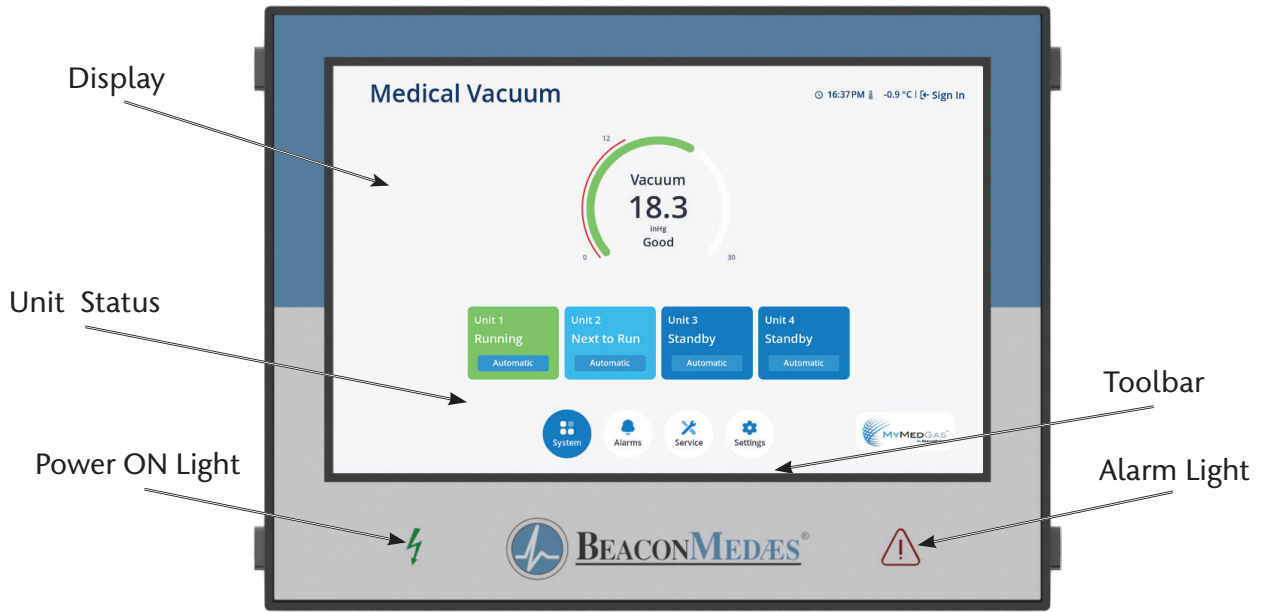


Figure 3A.2.2.2 Touchscreen Controls

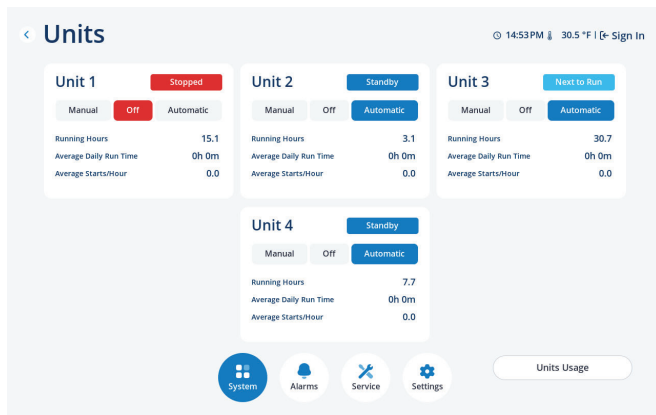


Figure 3A.2.2.3 Units Screen - Off Position

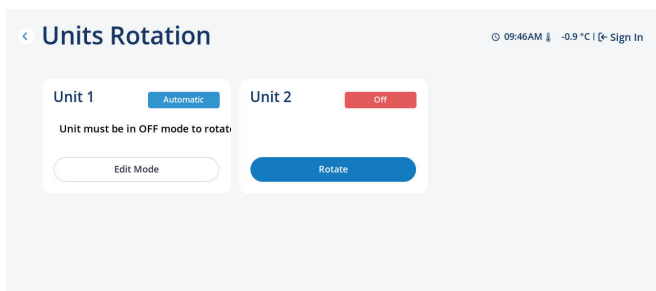


Figure 3A.2.2.4 Units Rotation Screen

By observing the cooling fan of the motor, you can

determine the rotation of the pump. After pressing the “Rotate” button on the touchscreen, there is a 5 second delay before the pump will start for a brief amount of time. Pump rotation should be counterclockwise when looking at the rear of the motor. Directional arrows are located on each pump.

If the pumps are rotating in the wrong direction, rotation can be reversed by switching any two main power leads to the panel. Correct rotation should be confirmed in the previous manner.

**WARNING:**  
Do not allow the vacuum pump to run backwards.

Repeat the process of switching the Unit printed circuit boards from the manual override “Off” position to the default “Automatic” position and testing rotation.

### 3A.3 Initial Operation

### 3A.0 Start Up - TotalAlert 360 Controls

Start each pump by pressing “Automatic” on the touchscreen. See Figure 3.3.1.

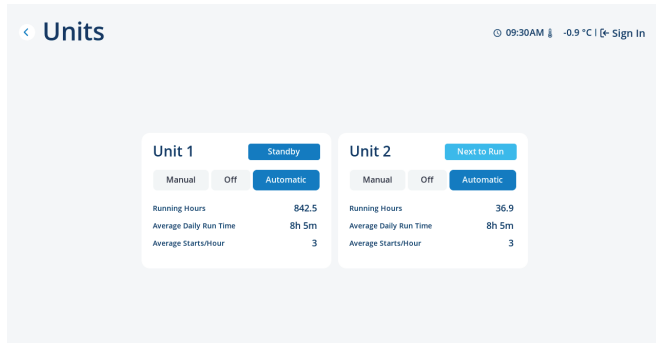


Figure 3A.3.1 Unit Screen - Automatic Mode

**WARNING:**

**Pumps that have reached operating temperature may have a high surface temperature on the top of the exhaust muffler.**

**DO NOT TOUCH!**

Run the pump for two minutes in the correct rotation. Stop the pump and top off the oil level utilizing the oil filler port to the correct level as shown in the sight glass. **DO NOT OPEN THE FILLER PORT WHILE THE PUMP IS RUNNING.**

After testing each pump, if everything appears normal, put each pump into the “Automatic” mode and allow each pump to run until vacuum builds. Check for any leaks in the piping. Repair leaks, if needed.

## 3B.0 Start Up - Basic Controls

**Note:** This section applicable to Lubricated Rotary Vane Medical Vacuum Systems with the Basic control system.

### 3B.1 Prestart-up

The contractor should notify **BeaconMedæx** two weeks prior to start-up date to schedule an appointment for an authorized technician to review the installation prior to start-up.

**CAUTION:** Failure to install the unit properly and have an authorized technician from **BeaconMedæx** start-up the system can void the manufacturer's warranties.

**WARNING:**

**Prior to putting the LifeLine® Lubricated Rotary Vane Medical Vacuum system into use, the medical facility must have a Certifier perform all installation tests as specified in NFPA 99. The medical facility is also responsible for ensuring that the Medical Vacuum meets the minimum requirements for Medical Vacuum as specified in NFPA 99.**

Prestart-up and start-up procedures should be performed for a new installation or when major maintenance has been performed.

**WARNING:**

**Have more than one person on hand during prestart-up and start-up procedures to ensure safety and to facilitate certain checks.**

The main power source to the control panel should be OFF for the duration of the visual inspection.

Ensure that the equipment is installed on a solid level surface. Walk around the system to ensure that there is enough clearance on all sides to perform operational checks/actions and maintenance. The temperature of the area containing the modules

should be approximately 70°F (21.1°C) with a minimum ambient temperature of 40°F (4.4°C) and a maximum ambient temperature of 105°F (40°C).

- Check the intake piping for proper size and connection to the vacuum modules.
- Check all piping system joints that might have come loose during shipment and installation to ensure they are tight.
- Check the air receiver, controls, and pumps for damage.
- Check the drain valve on the air receiver.
- Check all valves for full open and full close travel. Ensure that the system's valves are positioned for proper operation. (Refer to labeling on valve handles)
- **Remove all packing material from the unit.**
- Check the electrical connections to the control cabinet.
- Verify electrical service. Before starting the system, check to see that voltage, amperage, and wire size are appropriate.

**CAUTION:** Electrical service must be as specified or damage to equipment may occur.

**WARNING:**

**To prevent electrical shock, ensure that ALL electrical power to the system is OFF, including the disconnect switches and Automatic-Off-Manual switches on the control panel. The facility's supply circuit breaker should also be locked out.**

- Open the electrical cabinet by loosening the fasteners on the front.



## 3B.0 Start Up - Basic Controls

**CAUTION:** Vibration during shipment and installation can loosen electrical terminals, fuse inserts, and mechanical connections. Tighten as necessary.

- Check the electrical cabinet for any broken components.
- Check that all motor starter connections are tight and that there are no loose objects such as terminal lugs, screws, nuts, etc., in the cabinet.

### 3B.2 Initial Start-up

**CAUTION:** Complete the prestart-up procedure before continuing with the initial start-up procedure

**WARNING:**

**To prevent electrical shock, ensure that ALL electrical power to the system is OFF, including the disconnect switches. The facility's supply circuit breaker should also be locked out.**

**WARNING:**

**Do not allow the vacuum pump to run backwards.**

#### 3B.2.1 Lubrication

The pumps are oil lubricated. The lubricating oil can be put into the pump at the oil filler port of the oil separator housing, observing the "MAX" and "MIN" position at the oil level sight glass. (For recommended oil type, refer to Section 6.1.) After filling, make sure the oil filler port is closed.

All LifeLine® lubricated vacuum pumps are shipped with the required amount of oil for start-up. The systems are shipped with separate oil containers, which must be added before start-up.

#### 3B.2.2 Pump Rotation

Prior to actual operation, the pumps must be checked for correct rotation.

Apply power to the system and turn the disconnect switches to "On".

Check all voltages supplied to the LifeLine® system to ensure they are the required value and phases needed by the control panel.

Using the Hand-Off-Auto switch on the door of the control panel, jog the motor of the specific pump that is to be checked by momentarily turning the switch to "Hand" and back to "Off". By observing the cooling fan of the motor, you can determine the rotation of the pump. Pump rotation should be counterclockwise when looking at the rear of the motor. Directional arrows are located on each pump.

If the pumps are rotating in the wrong direction, rotation can be reversed by switching any two main power leads to the panel. Correct rotation should be confirmed in the previous manner.

Repeat the process of testing rotation for each vacuum pump.

### 3B.3 Initial Operation

Using the "Hand-Off-Auto" switch, start pump by switching to "Auto".

Run the pump for two minutes in the correct rotation. Stop the pump and top off the oil level utilizing the oil filler port to the correct level as shown in the sight glass. **DO NOT OPEN THE FILLER PORT WHILE THE PUMP IS RUNNING.**

**WARNING:**

**Pumps that have reached operating temperature may have a high surface temperature on the top of the exhaust muffler.**

**DO NOT TOUCH!**



### 3B.0 Start Up - Basic Controls

After testing each pump, if everything appears normal, put each pump into the “Auto” mode and allow each pump to run until vacuum builds. Check for any leaks in the piping. Repair leaks, if needed.



# 4A.0 General Operation - TotalAlert 360 Controls

**Note:** This section applicable to Lubricated Rotary Vane Medical Vacuum Systems with the TotalAlert 360 electronic control system.

reset once the system reaches its normal operating vacuum and the lag pump times out and stops. See Figure 4A.1.1.

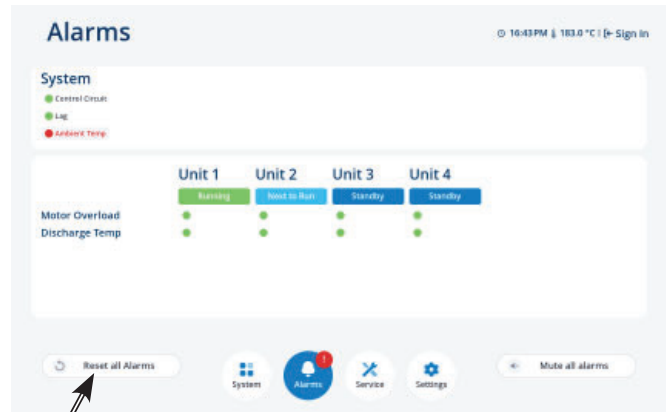
**WARNING:**  
**NEVER RUN THE PUMP WITHOUT LUBRICATING OIL!**

## 4A.1 Electrical Control Panel

The LifeLine multiplex control system is U.L. labeled. The control system has a touch screen control, automatic lead/lag sequencing, external operators with circuit breaker disconnects, full voltage motor starters, overload protection, 24V control circuit, and automatic-off-manual selector for each vacuum pump. Automatic alternation of all vacuum pumps is based on first-on/first-off principle with provisions for simultaneous operation if required. Automatic activation of reserve unit, if required, will activate an audible alarm as well as a visual alarm on the control panel. The control panel displays service alert, run hours for each vacuum pump, system status, system vacuum level, and high discharge air temperature. A complete alarm and service history is available on the control panel. (see Appendix A for more details)

During normal operation, all pumps should be in the “Automatic” position so that the control system can effectively run the system. The control system monitors the system vacuum level, starts and stops the pumps depending on changing vacuum level conditions and minimum run time values, and automatically alternates the lead position between units.

On the **initial** system start-up, when the system vacuum level is below the set point of the vacuum transducer, unit 1 will start immediately. Another unit starts after a programmed time delay. The time delay prevents high inrush current after a power failure or emergency power switch over. During this initial system start-up, the lag alarm may come on at this point and is normal. It can be



Reset Button

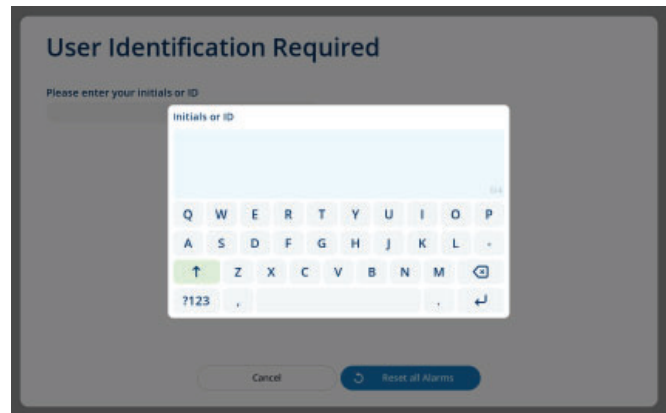


Figure 4A.1.1 Main Screen - Reset Button and User Identification

The control system sequences the pumps in number order (1, 2, 3, etc.). The control system only considers available units in the sequence. The number of available units is the number of pumps set to “Automatic” on-screen. The system will not count pumps set to “Manual” or “Off”. Example: A triplex system has Units 1 and 3 set to “Automatic” and Unit 2 set to “Off”. The control system will start/stop the pumps based on having only 2 units, and the sequence will be: 1, 3, 1, etc.

The control system will automatically start/stop the units at pre-defined system vacuum values. The start/stop values vary depending on the number

## 4A.0 General Operation - TotalAlert 360 Controls

of available units and the min/max system vacuum settings. The last available (lag) pump will come on at the min system vacuum level. The last pump running will turn off at the max system vacuum level if the minimum run time has been met. If not, the pump will continue to run until the minimum run time is achieved. Refer to the appropriate wiring diagram for the default vacuum settings.

This control system operates according to a “first on/first off” principle instead of the more traditional “last on/first off” principle. With the “first on/first off” sequencing technique, starts and stops on the pump are minimized. The “first on/first off” principle behaves as follows:

The control will signal the lead pump to start when system vacuum falls below the set point. Once the lead pump has started, the next available pump will read “Next to Run.” If the one pump can carry the load, then the system vacuum will rise to 22 inHg. At this point, the control will turn off the lead pump if the minimum run time has been met. When the system vacuum drops again, the control will automatically sequence the lead role to the “Next to Run” pump and will start it.

If one pump cannot carry the load, the system vacuum will continue to fall until it triggers the “Next to Run” pump to start. Once the second pump has started, the next available unit will read “Next to Run.” This will continue until the system vacuum stops falling or all available units have turned on. When the pumps can carry the load, the system vacuum will rise towards 22 inHg. The lead pump will be the first to stop. When the lead pump stops, the system will automatically sequence the lead role to the next available unit. If the system vacuum continues to rise, the new lead pump will be the next to turn off. If the system vacuum drops again, the “Next to Run” pump will be the next to start.

If during operation, the lag pump is required to come on, the control will turn on the “Lag Alarm” (see Section 4.3).

For maintenance or other reasons, pumps can operate in “Manual” position. The pump(s) in the “Manual” mode will run continuously.

### 4A.1.1 Run Timer

All LifeLine vacuum systems incorporate run timers to minimize the starts and stops on the vacuum pumps. After the pump has stopped, its runtime will automatically adjust based on how long the lead pump is off and the maximum run time set by the user.

## 4A.2 Tank Drains

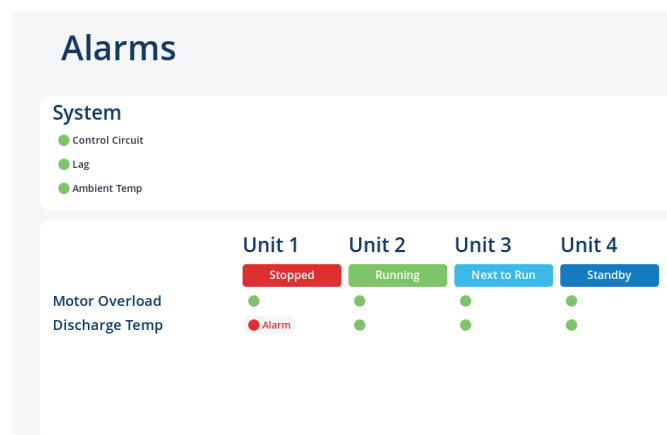
The standard tank drain consists of a manually operated ball valve.

To drain the liquid from the tank, open the tank bypass valve and close the tank isolation valves. Then open the vent and drain valves. When draining is complete, close the vent and drain valves first, then open the tank isolation valves and close the tank bypass valve.

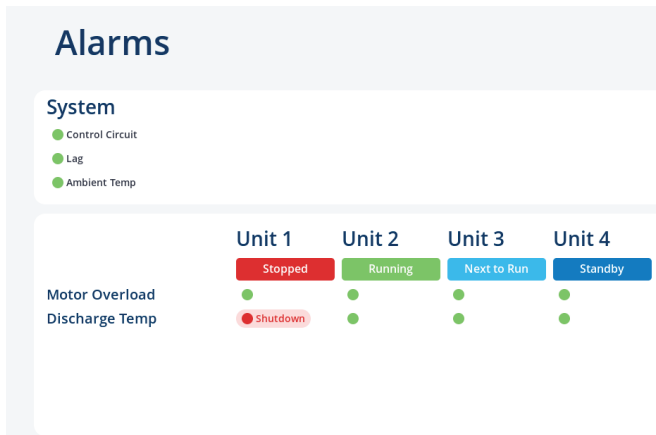
## 4A.3 Emergency Shutdown / Alarms

The following conditions may arise during operation. Alarm conditions will be labelled “Alarm” and shutdown conditions will be labelled “Shutdown”.

### 4A.3.1 Unit Shutdown / Alarms



## 4A.0 General Operation - TotalAlert 360 Controls



Unit Alarm/Shutdown

Figure 4A.3.1.1 Alarms Screen - Unit Alarm and Shutdown

**Motor Overload Shutdown** - This shutdown will activate if the motor current draw exceeds the set limit. This will shut down the pump in question and will not re-start until the reset button on the motor starter inside the main control cabinet is reset and “Reset all Alarms” is pressed on the control panel display. See “Motor breakers trip constantly” in the Troubleshooting Section 5.0.

**Discharge Temperature Shutdown** - This shutdown will activate if the outlet air temperature exceeds the set limit. This will shut down the pump in question and will not re-start until “Reset all Alarms” is pressed on the control panel. Before allowing the unit to re-start, the condition should be checked (see “Pump overheats” in the Troubleshooting Section 5.0). Even after resetting the alarm and putting the pump in “Automatic” mode, the unit may not re-start, depending on system sequencing and system vacuum.

**Discharge Temperature Alarm** - This alarm will activate if the outlet air temperature exceeds the set point. This will not shut down the pump in question but instead is a warning that a shutdown is likely to occur. The condition should be checked immediately (see “Pump overheats” in the Troubleshooting Section 5.0) to avoid a compressor shutdown.

### 4A.3.2 System Alarms

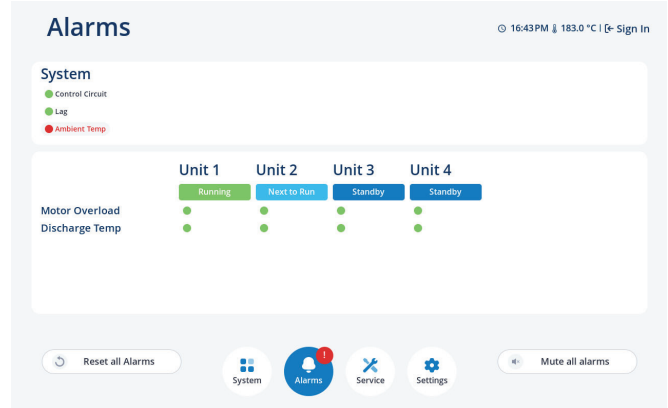


Figure 4A.3.2.1 Alarms Screen

**Control Circuit Alarm** - This alarm will activate if communication between any of the boards in the control circuit is disrupted. This will not shut down the pump in question but instead is a notification that there is a loss of communication between printed circuit boards within the control panel. See Appendix A on Control System for troubleshooting.

**Lag Alarm** - This alarm will activate if the last available unit activates bringing the total number of available units remaining to zero. This alarm will activate if the last available pump unit comes on. (See Section 4.1 for more information) To silence the alarm, press the “Mute all alarms” button. In the event the lag alarm is persistent, check to see if any leaks or valves are open upstream or reduce the system load.

**Ambient Temperature Alarm** - This alarm will activate when the temperature in the room exceeds the set point. The touchscreen will show an active alarm and record it in the event log. The alarm remains latched until the alarm condition is reset by the operator.

### 4A.3.3 Service Warnings

**Service Due Alarm** - Service intervals and type of service are preprogrammed into the control system. The service icon on the toolbar will get

## 4A.0 General Operation - TotalAlert 360 Controls

a red “!” symbol when one of these services are required. See Table 6.1 Maintenance Schedules.

### 4A.4 Backup Vacuum Switch Set Point Adjustments

The backup switch is set at the factory to the operating point(s) as stated on the wiring diagram supplied with the unit. It is good practice to cycle the switch to determine actual operating points before proceeding with readjustment. Refer to Figure 4A.4.1 for location of adjustment.

**CAUTION:**

- ALWAYS change vacuum setting gradually.
- ALWAYS check switch setting before making any adjustments.
- DO NOT force adjustment sleeve when it becomes difficult to turn.
- ALWAYS isolate the vacuum transducer before making any adjustments to the backup vacuum switch.

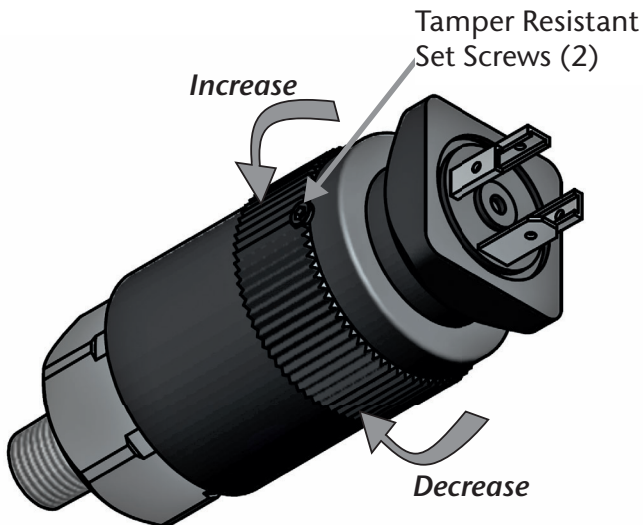


Figure 4A.4.1 Backup Vacuum Switch

Adjusting Instructions

1. To make an adjustment, loosen the tamper resistant set screws (2) on the adjustment sleeve.
2. Secure the hex body with an open-end wrench. Hand turn the adjustment sleeve: counter-clockwise to increase and clockwise to decrease the set point. The backup vacuum switch should always be set with falling vacuum level starting at a vacuum level higher than the setpoint.
3. Using the vacuum gauge determine the actuation point of the switch.
4. If the actuation point is above the desired value, turn the adjustment sleeve clockwise to decrease the actuation point, and if it is below, turn the adjustment sleeve counter-clockwise to increase it.
5. For exact vacuum setting, cycle vacuum switch and make fine adjustments by repeating steps 2 through 4 (trial and error process) until the desired setting is obtained.
6. Secure the tamper resistant set screws (2) on the adjustment sleeve.

**CAUTION: Do not overtighten set screws.**

## 4B.0 General Operation - Basic Controls

**Note:** This section applicable to Lubricated Rotary Vane Medical Vacuum Systems with the Basic control system.

**WARNING:**

**NEVER RUN THE PUMP WITHOUT LUBRICATING OIL!**

### 4B.1 Electrical Control Panel

The LifeLine multiplex control panel includes a visual and audible lag pump alarm and a 0-30”Hg vacuum gauge. It also has the following for **each pump**: 24V power supply with fuses, hourmeter, vacuum control switch, high discharge air temperature switch with alarm, illuminated Hand-Off-Auto switch, motor starter and circuit breaker with external disconnect. All components are enclosed in a NEMA 12 enclosure.

During normal operation, all H-O-A switches should be turned to the “Auto” position so that the PLC can effectively control the system. The PLC monitors the system vacuum switch condition, starts and stops the pumps depending on changing vacuum switch conditions and minimum run time values, and automatically alternates the lead position between units.

In a typical **duplex** system, one pump will be able to handle the system load. The PLC will signal the lead pump to start when the lead vacuum switch (VS-1) closes with decreasing vacuum level. If the one pump can carry the load, then the vacuum level will rise and VS-1 will open. At this point, if the minimum run timer for that pump has been satisfied, the PLC will turn off the lead pump. If the minimum run timer for that pump has not been satisfied, the lead pump will continue to run until the timer expires. When the system vacuum drops again and VS-1 closes, the PLC will automatically sequence the lead role to the other pump and will start it. This is also known as “first on/first off” instead of the more traditional “last on/first off”. With the “first on/first off” sequencing technique, starts and stops on the pump are minimized. If the

lead pump runs continuously in lead for more than 15 minutes, the PLC will automatically sequence the pump attempting to evenly distribute the run time among all available pumps. (This value is variable and is equal to the current minimum run time value.) If during operation, the second pump is required to come on in addition to the lead pump, the PLC will turn on the “Lag Alarm”.

In a **triplex** or **quadruplex** system, the operation is very similar to the duplex operation described above with the following differences. For each additional pump, there is an additional vacuum switch. (Refer to the wiring diagram that came with the unit for actual vacuum switch setpoints.) With a triplex or a quadruplex system, the lag unit running alarm may not necessarily correspond to the third or fourth pump coming on. To determine when the PLC turns on the lag alarm, it counts the number of units in the “Auto” position and makes a decision based on the vacuum switch conditions. For instance, in a quadruplex system with only 2 H-O-A switches in the “Auto” position, the lag alarm will turn on when the second unit is started (or the lag vacuum switch VS-2 closes).

On the **initial** system start-up, when the system vacuum level is below the setpoints of the vacuum control switches, pumps 1 and 4 will start. After a 7 second delay, pump 2 will start. After another 7 second delay, pump 3 will start. The time delay is to prevent high inrush current after a power failure or emergency power switch over. During this initial system start-up, the lag alarm will come on at this point and is normal. It can be reset once the vacuum level is high enough to open the lag vacuum switch. Refer to the wiring diagram supplied with the system for the correct vacuum switch settings.



## 4B.0 General Operation - Basic Controls

### 4B.2 Tank Drains

The standard tank drain consists of a manually operated ball valve.

To drain the liquid from the tank, open the tank bypass valve and close the tank isolation valves. Then open the vent and drain valves. When draining is complete, close the vent and drain valves first, then open the tank isolation valves and close the tank bypass valve.

### 4B.3 Emergency Shutdown / Alarms

The following conditions may arise during operation.

**Motor Overload Shutdown** - This will shut down the pump in question and will not re-start the pump until the reset button on the starter inside the main control cabinet is reset. See Section 5 for troubleshooting information.

**High Discharge Exhaust Temperature Shutdown** This will shut down the vacuum pump in question and not re-start the pump until the condition is corrected and the appropriate red push button is pressed on the main control panel. Before allowing the unit to re-start, the condition should be checked (see "Pump overheats" in the Trouble Shooting Section 5.0). Even after resetting the alarm and putting the vacuum unit in "Auto" mode, the unit may not re-start, depending on system sequencing and system pressure.

**Lag Unit Running Alarm** - This alarm will activate if the last available vacuum pump comes on. In the case of a duplex system, it will activate when the second pump turns on or the lag vacuum switch (VS-2) closes. In the case of a multiplex system, the lag alarm will activate when the last available unit is required to come on. For example, in a quadruplex system, if all four (4) H-O-A switches are set to "Auto", then the lag alarm will trigger when the fourth unit comes on. If on the same system, three (3) of the four (4) H-O-A switches are set to "Auto" and the other to "Off" or "Hand", then the lag alarm will activate when the third

unit comes on. To silence the alarm, press the amber push button. In the event the lag alarm is persistent, check to see if any leaks or valves are open downstream or reduce the system load.

Please note that the lag alarm may be reset even if the lag pump is still running. This can happen due to the minimum run timer not having expired, but the lag vacuum switch itself may be open.

### 4B.4 Vacuum Switch Set Point Adjustments

The vacuum switch is set at the factory to the operating point(s) as stated on the wiring diagram supplied with the unit. It is good practice to cycle the switch to determine actual operating points before proceeding with readjustment. Refer to Figure 4B.4.1 for location of adjustment.

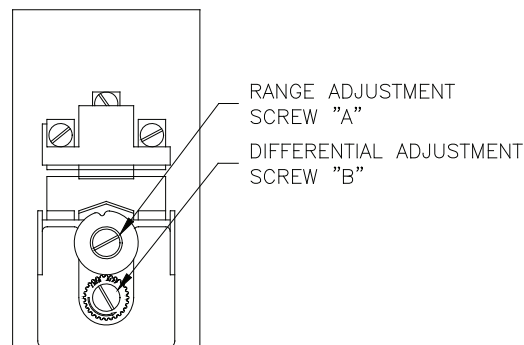


Figure 4B.4.1 Vacuum Switch

#### Adjusting Instructions

1. First - Adjust the range (screw "A") to the required cut-in vacuum setting. Turning the screw clockwise lowers the cut-in and cut-out vacuum settings equally.
2. Second - Adjust the differential (screw "B") to the required cut-out vacuum setting. Turning the screw counter-clockwise will increase the cut-out vacuum setting. Turning the screw counter-clockwise will increase the cut-out vacuum setting only. Differential is the difference between cut-in and cut-out settings.



## 5.0 Troubleshooting

Problem	Possible Causes	Solution
Power failure	Main power disconnected	Turn on main power Change power supply phase on incoming power
	Power Failure	Restore power
	Main fuse blown	Replace fuse
	Fuse blown in control circuit	Replace fuse
Failure to start	Overload tripped on starter	Reset & check for system overload
	High temperature sensor activated	Allow unit to cool; reset alarm & check for over temperature condition
	Vacuum sensor open	Adjust or replace sensor
	Loose or faulty connection	Check & tighten all wire connections
Unit lacks sufficient vacuum or lag alarm has occurred	System may not be vacuum tight.	Check hose/pipe and connections for possible leaks.
	The oil tank may be low/empty of oil.	Immediately shut off the pump, drain the remaining oil from the tank and replenish with new fresh oil.
	The oil tank has contaminated oil or was filled with the incorrect type of oil.	Make sure the pump has reached its operating temperature before shutting down and replace with fresh new oil. Refer to section 6.2 for the correct oil type.
	Clogged inlet filter	Clean filter.
	Inlet check valve plate assembly may be worn or damaged due to process contamination.	Disassemble valve plate assembly, clean, replace worn or damaged parts and reassemble.
	Leaking oil lines on the pump could introduce an atmospheric pressure bleed spoiling the vacuum.	Check all oil lines for leakage. Replace or tighten as required. Make sure to use the same size and type of line when replacing.
The exhaust oil filter may be clogged.	Measure the amount of pressure between the exhaust side of the pump cylinder and the exhaust oil separator(s). The separator element(s) must be replaced if this pressure is near 0.7 bar or greater (approximately 10 psig).	

## 5.0 Troubleshooting

Problem	Possible Causes	Solution
Unit lacks sufficient vacuum or lag alarm has occurred (continued)	Insufficient pump speed (RPM)	Check voltage and amperage to motor.  Inspect motor and coupling halves.  Check that the pump shaft turns freely.
	Defective gaskets	Inspect gaskets for breakage or disintegration. Replace if necessary.
	Line losses too high	Piping diameter too small- replace with larger diameter.  Check for clogged filter elements - replace if necessary.
Unit lacks sufficient vacuum	Unit is operating at an elevated altitude	Contact the factory for assistance. Performance may be reduced when operating above sea level (see Section 2.4).
	Exhaust valve may not be properly seated or stuck open.	Contact the factory for assistance. Have pump model and serial number available.
	Shaft seal may be leaking.	
	Radial clearance between rotor and cylinder may need adjustment.	
	Internal parts may be damaged or worn.	
	Transducer fault with lag alarm.	Replace Transducer (TAE controls only).
Motor breakers trip	Defective motor	Test motor and replace if necessary.
	Low motor voltage	Check at motor terminals.  Contact electric service provider.
	Ambient temperature too high	Reduce ambient temperature.
	Stuck rotor	Disassemble pump to determine reason. Replace all necessary parts.
	Clogged exhaust oil separator(s) - back pressure too high	Replace separator(s).

## 5.0 Troubleshooting

Problem	Possible Causes	Solution
Unit runs rough and cannot be rotated manually	Broken rotor vane	Disassemble unit and replace vane. Check cylinder for wear.
	Worn coupling disc	Remove motor and inspect rubber coupling disc and pins. Replace, if necessary, and realign.
	Seized bearings	Remove end shields and inspect cylinder. Replace if necessary. Re-shim bearings to maintain proper clearance.
	Locked rotor	Remove end shields and inspect cylinder. Remove contamination.
Pump overheats	Cooling ducts blocked	Clean cooling ducts.
	Cooling fan broken	Replace fan.
Smoke/Oil Mist (emitted) from exhaust (port)	Pump is overfilled with oil.	Adjust oil level to proper setting as recommended in Section 3.2.
	Exhaust filters not correctly seated or installed	Check filters
	Pump is operated at vacuum levels outside the recommended range on a continuous basis.	Consult factory for assistance.
Runs excessively hot	Pump does not have adequate ventilation for cool operation.	If pump is installed in an enclosure, make sure re-circulation of hot exhaust cooling air is avoided and pump receives enough fresh cooling air. Do not block cooling air entrance to pump. Do not allow the pump to become covered with dirt, dust or process material. This will act as an insulator which may severely damage the pump.
	Pump is operated at vacuum levels outside the recommended range on a continuous basis.	Consult factory for assistance.

## 5.0 Troubleshooting

Problem	Possible Causes	Solution
Runs excessively hot (continued)	The oil tank may be low/empty of oil, has contaminated oil or was filled with an incorrect type of oil.	If the oil level is found to be low, immediately shut off the pump, drain the remaining oil from the tank and replenish with new fresh oil. If an incorrect oil type or contamination is found, make sure the pump has reached its operating temperature before replacing with new fresh oil. Refer to Section 6.2 for the correct type of oil.
Excessive noise level	The coupling rubbers may be worn.	Call the factory for replacements.
	Worn bearings	Call the factory for replacements.
Pump has seized	Pump may have been operated without enough oil.	Call the factory for assistance. Have pump model and serial number available.  <b>NOTE:</b> If liquid is found to have been ingested or if process vapor is condensing inside the pump, protective measures must be taken. Install trap or filter device on inlet of pump to remove the contaminate from the air stream.
	Liquid may have been ingested into pump.	
	Process vapor may have condensed inside pump.	
Pump has seized	Pump may have been operated in the wrong direction for an extended period of time.	Call the factory for assistance. Have pump model and serial number available.
Pump motor draws high amperage or pump starts but labors	Pump is operating in the wrong direction.	Make sure pump is operating in the proper direction. See rotation arrow on the pump.
	Ambient temperature may be too low for the recommended oil.	Multi-weight non-detergent oil may be required. Contact the factory for assistance.
	The exhaust oil filter may be clogged.	This can be checked by measuring the amount of pressure between the exhaust side of the pump cylinder and the exhaust oil separator(s). The separator element(s) must be replaced if this pressure is near 0.7 bar or greater (approximately 10 psig).
	Make sure the pump is not overfilled with oil or that the wrong type of oil has been used.	Adjust oil level to proper setting or replace oil with the correct type. Refer to Section 6.2 for the correct oil type.

## 5.0 Troubleshooting

Problem	Possible Causes	Solution
Pump motor draws high amperage or pump starts but labors (continued)	The wiring connection in the electrical circuit may have become loose.	Check all connections and tighten or replace as required.
	Make sure the electrical circuit is properly sized to handle load.	Wiring sized too small will create a voltage drop large enough to produce over amperage of motor. Check line voltage for unusually low supply voltage.
	Motor damage may have occurred.	Consult a qualified electrician for further diagnosis.
	A bearing may be worn.	Call the factory for replacement. Please have the pump model and serial number available.
	Process vapor may be condensing inside pump.	Stop pump, change oil and install protective devices on inlet of pump to prevent recurrence.



## 6.0 Maintenance

### 6.1 General Maintenance

**WARNING:**

**ISOLATE POWER BEFORE STARTING ANY MAINTENANCE PROCEDURES, TO PREVENT ELECTRICAL SHOCK OR ACCIDENTAL STARTING OF EQUIPMENT.**

**WARNING:**

**Pumps that have reached normal operating temperature may have a high surface temperature.**

**Do not perform any maintenance until after a sufficient cool down period.**

**Never perform any maintenance functions while the unit is in operation.**

**Table 6.1.1 Maintenance Schedule**

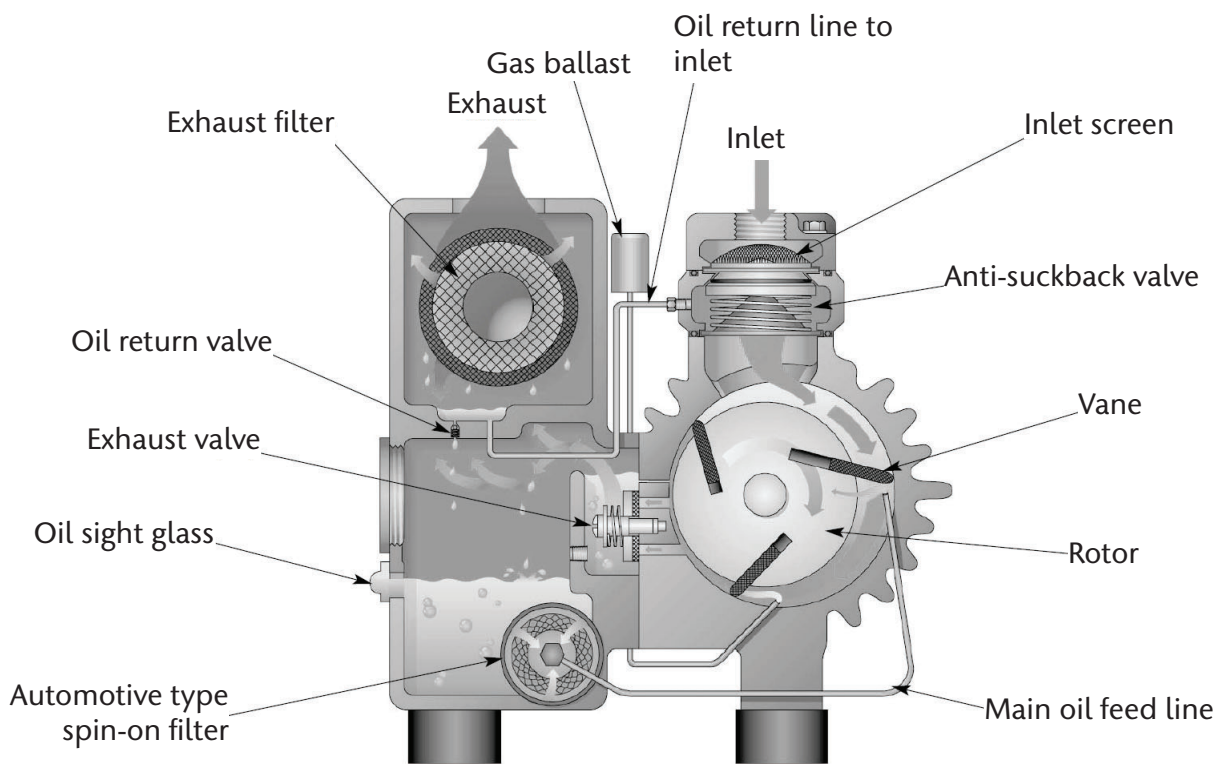
Item	Frequency	Action
Exhaust drip leg	Daily/Adjust as needed	Check for accumulated moisture
Oil / Oil Filter	500 hours	Change oil and replace oil filter
Exhaust filters	Check monthly	Check monthly and replace if required.
	Replace annually	Replace exhaust filters.
Inlet filter screens / Inlet filters	Check monthly and Replace annually	Clean as required.
<b>Motor bearings*</b> 1.5 - 10 HP motors 15 - 20 HP motors 25 Hp motors	Every 2 Years	8 grams of grease per fitting 17 grams of grease per fitting 23 grams of grease per fitting
<b>Coupling</b>	Every 2 Years	Inspect coupling rubbers for wear. Replace as needed

\* Motors have been lubricated at the factory. Motors that do not have the re-grease capability (no grease fittings) are factory lubricated for the normal life of the bearings. Refer to the service manual for grease specifications.

## 6.0 Maintenance

Maintain the pump regularly to achieve the best operating results. Maintenance intervals will depend on the pump's use and ambient conditions. Each pump in the LifeLine system is a lubricated rotary vane vacuum pump.

**Do not run pumps without lubricating oil.**



**Figure 6.1.1 Vacuum Pump**



## 6.0 Maintenance

### 6.2 Oil

#### 6.2.1 Oil Type

Non-detergent oil should be used. Do not use detergent motor oil as additives in detergent will plug exhaust filter elements and shorten their life.

It is recommended that BeaconMedaes oil be used to receive the best performance from your vacuum equipment. BeaconMedaes oil is a high quality vacuum oil which will give longer running time between oil changes, will provide better lubrication at high operating temperatures, and will prolong the life of the exhaust filter elements.

**NOTE:** It is important to completely drain oil from the pump, if changing brands.

#### 6.2.2 Oil Level

**WARNING:**

**Do not add oil while the pump is running since hot oil vapor may escape through the oil fill port.**

**WARNING:**

**Insufficient oil quantity in the pump has the potential, under certain conditions, to lead to self-ignition of the remaining oil in the pump.**

Check the oil level daily by observing the built-in sight glass. Each pump requires the proper oil to operate correctly (see Section 6.2.1 for the correct oil types). The oil should be changed every 500 hours of operation. The oil will need to be changed more frequently when operating at ambient temperatures above 105°F.

Oil level readings should be done only when the pump is turned off. Oil can be added to the oil fill port if the pump is shut off and the circulating oil has sufficient time to return to the oil sump.

The oil might appear foamy, which is a normal phenomenon with aerated oil.

The technical data in Table 6.2.2.1 gives the approximate quantities of oil required for each pump. The oil capacity chart should only be used as a guide, since oil capacity may be slightly lower, depending on whether the pump was filled previously, and whether all components such as oil filter, oil lines, etc. were allowed to completely drain. Use only the sight glass reading for proper level. **Never overfill.**

To change the oil, the pump must be switched off and ventilated to reach atmospheric pressure. Open the oil drain valve and drain the oil. When the oil stops draining, close the drain valve.

Start the pump again for a few seconds. Stop the pump once again, and then reopen the drain valve and discharge any remaining oil. Close the drain valve.

**CAUTION:** Oil filters and used oil must be disposed of corresponding with the relevant health, safety and environmental laws.

After changing the oil filter (see Section 6.2.3), fill the pump with the recommended vacuum oil through the oil filling port, observing “MAX” and “MIN” position on the oil level sight glass.

**Table 6.2.2.1 Oil Quantity per Pump**

Unit Size	Oil Quantity (quarts)
1.5 Hp	1.4
2 Hp	1.4
3 Hp	2.5
5 Hp (RC0101 and RA0100)	2.7
5 Hp (RC0155 and RA0155)	7.0
7.5 Hp	7.0
10 Hp	7.0
15 Hp	14
20 Hp	16
25 Hp	16

## 6.0 Maintenance

### 6.2.3 Automotive-Type Oil Filter

The pump is equipped with an automotive-type oil filter. (See Figure 6.1.1 for location.)

Replace the oil filter when changing the oil. After draining the oil, remove the oil filter and replace it with a new one using a BeaconMedæ's oil filter. Make sure to tighten the filter securely against the aluminum sealing surface so that leaks will not occur.

### 6.3 Drip Leg and Filters

#### 6.3.1 Exhaust Drip Leg Valve

Each pump should have a drip leg at the exhaust port on the pump. This valve should be checked daily at first, then depending on the moisture accumulated, could be checked less frequently.

#### 6.3.2 Inlet Filter

**WARNING:**

**Filter elements and drain flasks are biohazard materials and need to be handled with proper care.**

**WARNING:**

**Proper Personal Protective Equipment (PPE) must be worn when servicing this equipment.**

The capacity of the vacuum pump can be reduced if the air inlet filters (M) are not maintained correctly. The inlet filter cartridges should initially be cleaned monthly and changed yearly depending on the degree of contamination.

A PPE kit is available through BeaconMedæ's. The kit includes a XL disposable coverall, N100 disposable respirator, wrap-around safety glasses, and two heavy-duty 30-gallon biohazard waste bags. The P/N for the kit is 4107 4018 65.

In addition to the PPE kit, below are the recommended gloves to be worn when servicing this equipment:

Grainger P/N: 2VLZ8

- o Description: 9-1/2" Powder Free Unlined Nitrile Disposable Gloves, Black, Size L, 100PK

Grainger P/N: 2VLZ9

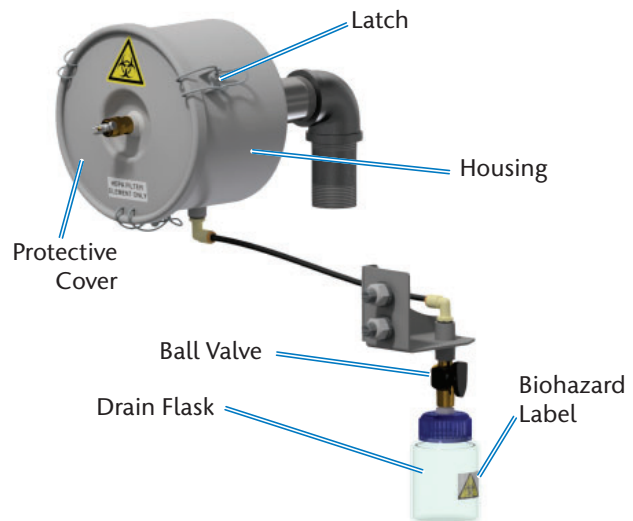
- o Description: 9-1/2" Powder Free Unlined Nitrile Disposable Gloves, Black, Size XL, 100PK

It is recommended to replace the drain flask with every filter element change. The drain flask is available through BeaconMedæ's. The P/N for the flask is 4107 6558 95.

The drain flask is also suitable for steam sterilization up to 273 °F (134 °C) using hospital equipment and procedures.

To replace the filter and drain flask:

1. Turn off the pump being serviced and lock open the appropriate disconnect switches.



**Figure 6.3.2.1 Intake Filter**

## 6.0 Maintenance

2. Close intake isolation valve.
3. Close the ball valve attached to the drain flask, unscrew the drain flask, and dispose of it using the hospital procedure for biohazard waste.
4. Open the ball valve to relieve the vacuum in the filter assembly and ease in removing the filter housing.
5. Remove the protective cover by loosening the latches.
6. Remove the element.
7. Clean inside of housing
8. Dispose of gloves. Put on a new pair of gloves before proceeding further.
9. Insert a new element (note orientation of the element).
10. Replace protective cover and tighten latches.
11. Place the new biohazard label on the new drain flask.
12. Place a sealing washer over the fitting on the drain flask cap
13. Reinstall the drain flask by screwing it onto the ball valve.
14. Open intake isolation valve.
15. Turn on the compressor. Close butterfly valves on both sides of filter being serviced.
16. Dispose of all contaminated PPE.

### 6.3.3 Exhaust Filter

Exhaust filters should be checked monthly. A pressure gauge is supplied as part of the oil fill plug. This gauge has a green field and a red field. A pressure within the green field indicates normal pressure. Any pressure in the red field (for a continuous period of time) requires an immediate change of the exhaust filter(s). Annually, or as necessary, replace the exhaust filter elements.

**For 1.5 Hp, 2 Hp, 3 Hp and 5 Hp**  
5 Hp pump model RC0101 and RA0100.

Incorporated into horizontal tankmount system designs.

**NOTE:** Refer to Figure 6.5.3.1 for numbers referenced below in parenthesis.

To replace the exhaust filters, unscrew the screws (146) and lockwashers (143) from the exhaust cover plate (145). Remove cover plate and gasket (141).

Use a slotted head screw driver to loosen the exhaust filter retaining spring (125), then rotate and remove the spring. Pull the filter cartridge (120) out of the exhaust box.

Reinstall the filter elements. Make sure the open end of the element is properly seated down in its recess in the exhaust box with the O-ring (121) correctly positioned. The indicating arrow on each filter element must be pointing upward toward the top of the exhaust box after the assembly has been installed.

Retain the filter with the spring clip (125), tighten the tension screw until the filter is secure.

Place the exhaust port gasket (141) and cover (145) in position on the exhaust box and retain with the cap screws (146) and lockwashers (143).

### **For 5 Hp (RA0155)**

**NOTE:** Refer to Figure 6.5.3.2 for numbers referenced below in parenthesis.

To replace the exhaust filters, unscrew the screws (142) and lockwashers (143) from the exhaust cover plate (140). Remove cover plate and gasket (141).

Use a slotted head screw driver to loosen the exhaust filter retaining spring (125), then rotate and remove the spring. Pull the filter cartridge (120) out of the exhaust box.

Reinstall the filter elements. Make sure the open end of the element is properly seated down in

## 6.0 Maintenance

its recess in the exhaust box with the O-ring (121) correctly positioned. The indicating arrow on each filter element must be pointing upward toward the top of the exhaust box after the assembly has been installed.

Retain the filter with the spring clip (125), tighten the tension screw until the filter is secure.

Place the exhaust port gasket (141) and cover (140) in position on the exhaust box and retain with the cap screws (142) and lockwashers (143).

### **For 5 Hp (RC0155), 7.5 Hp, and 10 Hp**

5 Hp pump model RC0155. Incorporated into basemount system designs.

**NOTE:** Refer to Figure 6.5.3.3 for numbers referenced below in parenthesis.

To replace the exhaust filters, unscrew the screws (142) and washers (143) from the exhaust cover plate (140). Remove cover plate and gasket (141).

Remove the distance pin (137), the baffle strainer (130) and the sheet metal plate (136).

Remove the discharge filter assembly by unscrewing the nut (134) and removing the lockwasher (132). Carefully slide the assembly out of the exhaust box. Stand the filter assembly up on a clean flat surface. To access the individual filters, unscrew the two cylinder cover screws (126), remove the two lockwashers (128) and remove the exhaust filter grip plate (115).

Remove the exhaust filters (120) and O-rings (121). Remove the filter support (118) and O-rings (119).

Replace the support and O-rings with new ones. Make sure that the O-rings are fitted securely and that the filter elements (120) fit securely into the depressions on the filter support (118). The indicating arrow on each filter element must be pointing upward toward the top of the exhaust box after the assembly has been installed.

Carefully position the filter support tube (133) between the exhaust filter grip (115) and the filter support without displacing the filters from their seated position in the filter support. Install the two lockwashers (128) and two screws (126).

Insert the support and filter assembly into the exhaust box using the stud (131) as a guide. The stud should slide through the hole in the support (133). Secure the assembly with the lockwasher (132) and hexagon nut (134).

Reinstall the sheet metal plate (136) and the baffle strainer (130) into the guide track of the exhaust box. Press to the bottom of the exhaust box and make sure that the baffle strainer touches all sides of the exhaust box. Insert the distance sleeve (137) into the two grooves. This holds the sheet metal plate and baffle strainer in place.

Inspect the exhaust box and cover gasket (141) for damage and replace if damaged. With the gasket in place, secure the exhaust cover end plate (140) to the exhaust box using eight hex head cap screws (142) and eight lockwashers (143).

### **For 15 Hp, 20 Hp, and 25 Hp**

**NOTE:** Refer to Figure 6.5.3.4 for numbers referenced below in parenthesis.

To replace the exhaust filters, unscrew the screws (142) and lockwashers (143) from the exhaust cover plate (140). Remove cover plate and gasket (141).

Use a slotted head screw driver to loosen the exhaust filter retaining spring (125), then rotate and remove the spring. Pull the filter cartridge (120) out of the exhaust box.

Reinstall the filter elements. Make sure the open end of the element is properly seated down in its recess in the exhaust box with the O-ring (121) correctly positioned. The indicating arrow on each filter element must be pointing upward toward the top of the exhaust box after the assembly has been installed.

Retain the filter with the spring clip (125), tighten the tension screw until the filter is secure.

Place the exhaust port gasket (141) and cover (140) in position on the exhaust box and retain with the cap screws (142) and lockwashers (143).

## 6.4 Bearings

### 6.4.1 Greasing the Motor Bearings

If greasing the motor becomes necessary, wipe the fittings completely clean and use clean equipment. More bearing failures are caused by dirt introduced by greasing than from insufficient grease. Be careful not to over-grease the motor. If this occurs, the excess grease will spill out of the motor and drip onto the vacuum pump.

Use good quality rust inhibited polyurea-based grease, such as Chevron SRI. Motors that do not have re-greasing capabilities (no grease fittings) are factory lubricated for normal bearing life.

## 6.5 General Inspections

### 6.5.1 Monthly Inspections

A general inspection should be performed on a regular basis (monthly) for safety items. Items to inspect include all wiring, flex hoses, and other items. If a damaged item is viewed, call your local **BeaconMedæx** service technician for a thorough inspection and report of findings.

### 6.5.2 Every Six Months

A thorough inspection of the vacuum pump cooling air intake and discharge grating should be performed at least every six months or more frequently if conditions require. If a dust/dirt buildup is visible, clean the grating to remove the buildup. Excess dust/dirt buildup in these areas will prevent air from cooling the vacuum pump, affecting performance of the vacuum system.

### 6.5.3 Oil Leak

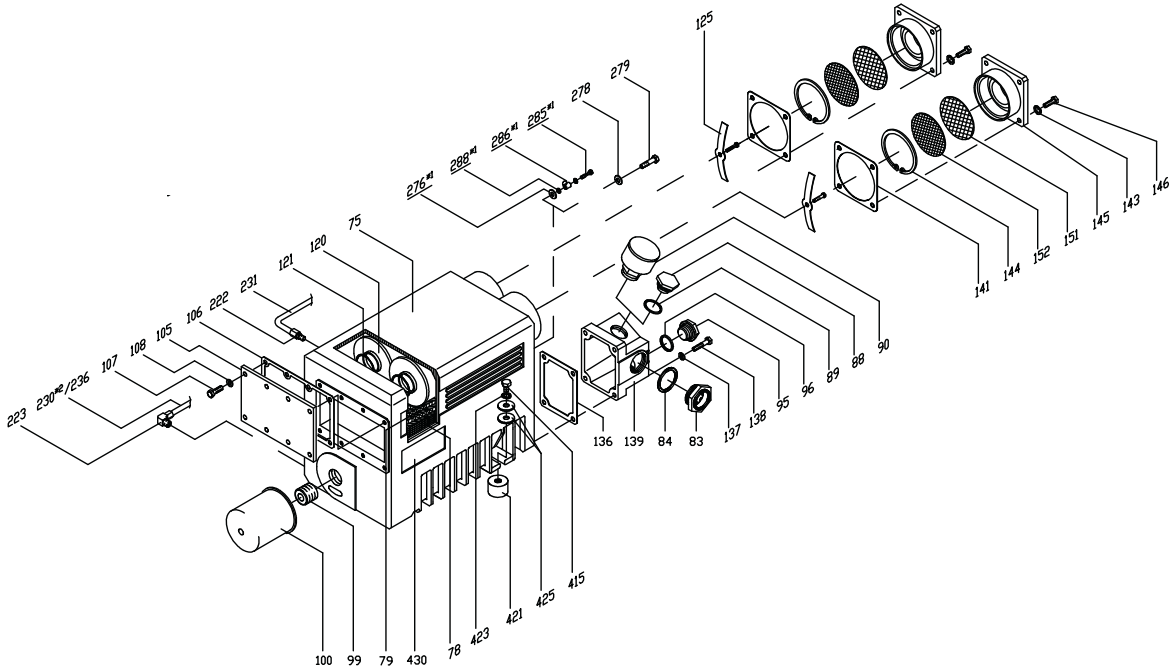
If upon inspection of the vacuum system, a noticeable amount of oil is seen on the base of the system or on the floor around the system, immediate action is required to prevent the possibility of injury. Using an oil absorbent or like product, absorb the oil on the base frame or floor to remove the potential of slipping. Call your local **BeaconMedæx** service technician for a thorough inspection of the vacuum pumps.

## 6.6 Cleaning

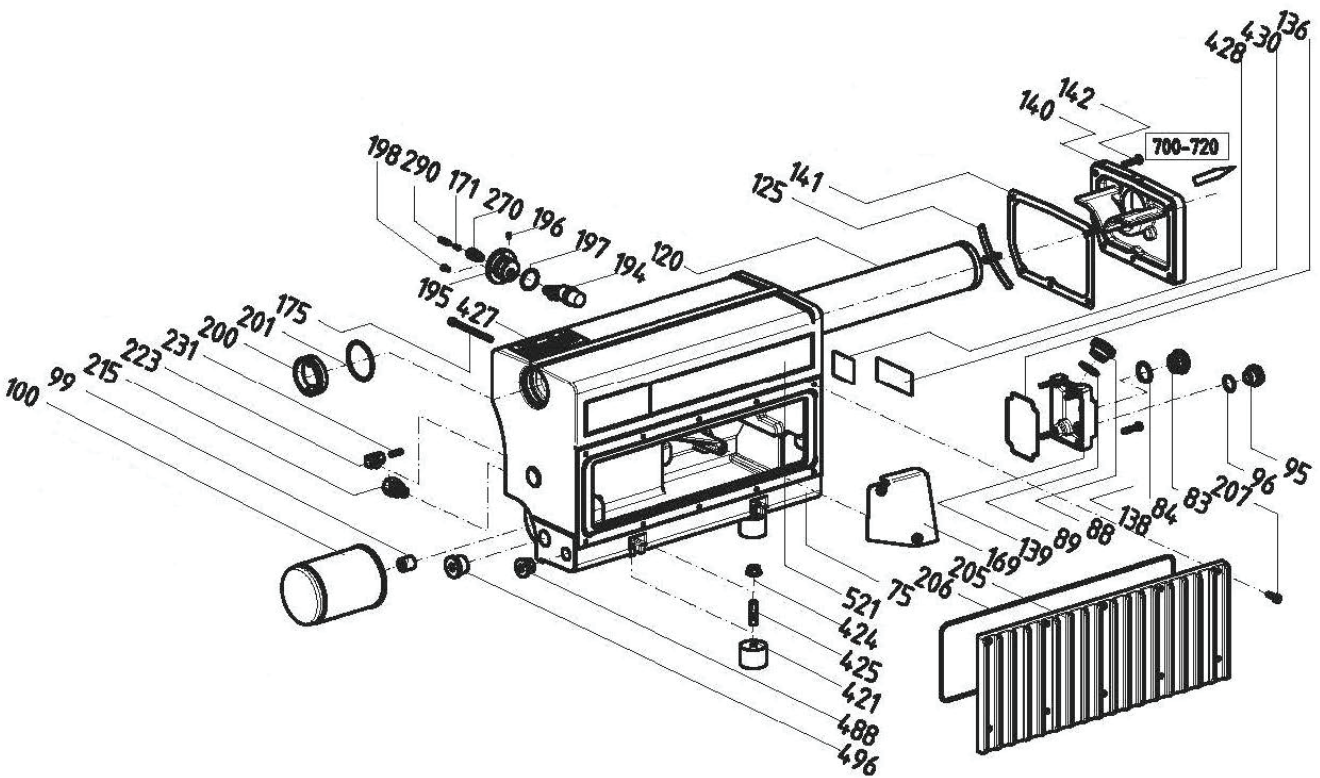
Use clean, dry or damp microfiber cloth or soft lint-free cloth to remove any smudges on the display. Do not apply excessive pressure while cleaning. Never use paper towels or tissue paper, which contain wood fibers that may cause scratches.



## 6.0 Maintenance

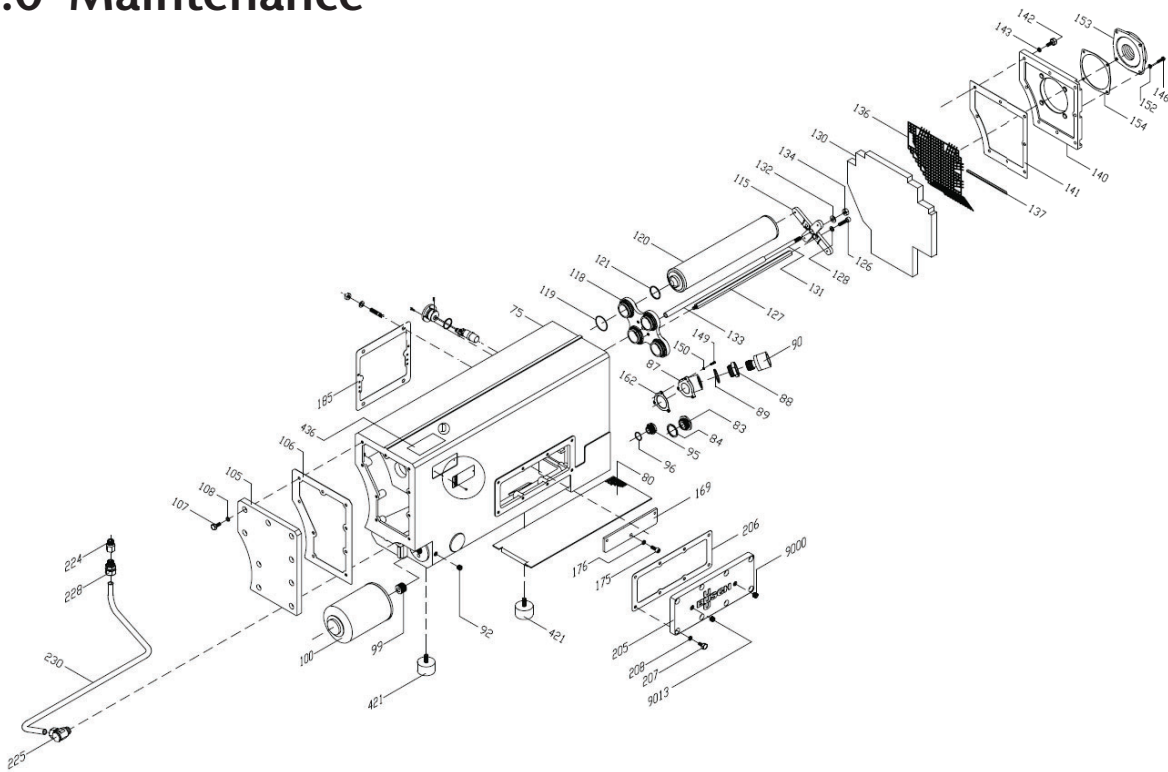


**Figure 6.5.3.1 Exhaust Filter (1.5 Hp through 5 Hp RC0101 and RA0100)**

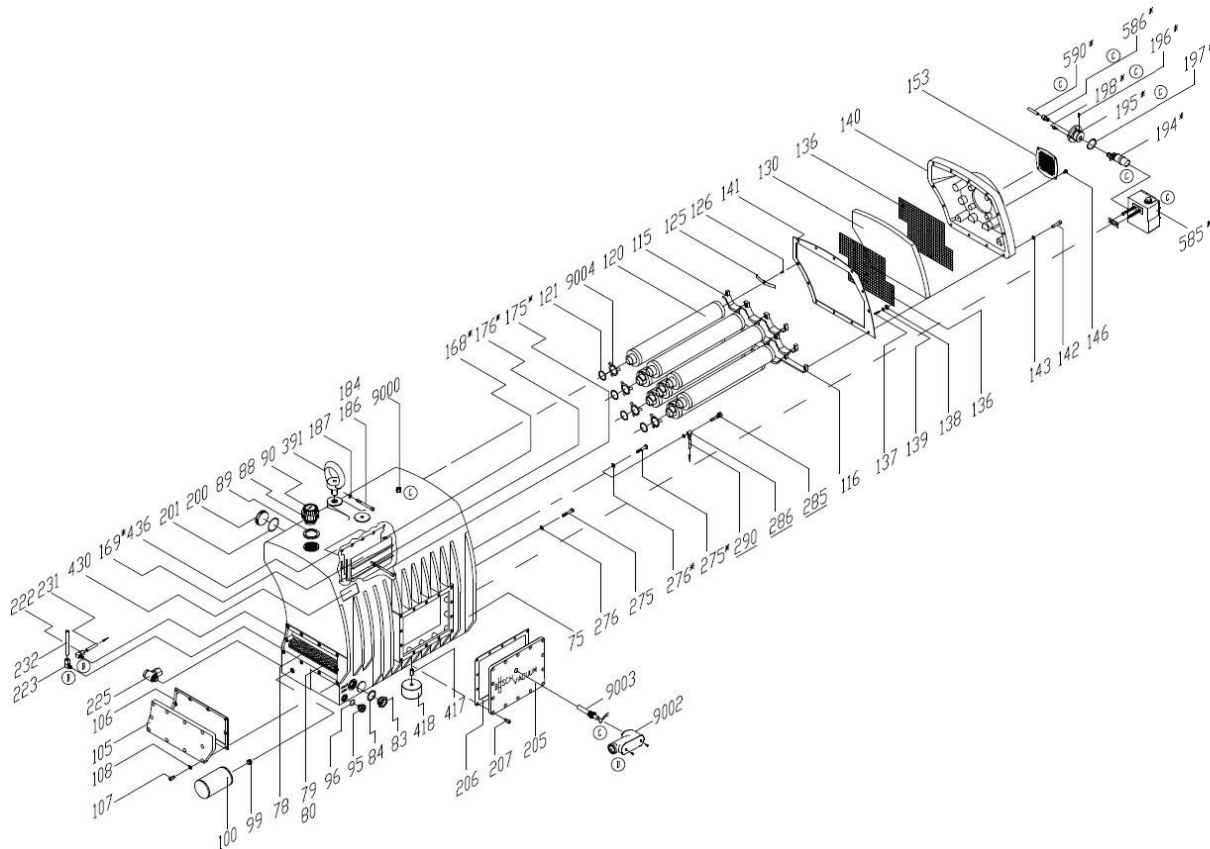


**Figure 6.5.3.2 Exhaust Filter (5 Hp RA0155)**

## 6.0 Maintenance



**Figure 6.5.3.3 Exhaust Filter (5 Hp RC0155 through 10 Hp)**



**Figure 6.5.3.4 Exhaust Filter (15 Hp through 25 Hp)**





## 7.0 Replacement / Maintenance Parts

### 7.1 Service Kits for Lubricated Vane Systems

KIT NUMBER	DESCRIPTION	QTY	WHERE USED	CONTENTS
<b>1-Year Basic Service Kit -Standard Filters</b>				
4107 4001 84	Unit Kit, Basic Service Kit A, 1.5 - 2 Hp	1 per pump	1.5 - 2 Hp	Inlet filter element, Exhaust filter with O-ring, Cover gasket
4107 4001 85	Unit Kit, Basic Service Kit B, 3 - 5 Hp	1 per pump	3 - 5 Hp <sup>1</sup>	Inlet filter element, Exhaust filter with O-ring, Cover gasket
<b>1-Year Basic Service Kit - HEPA Filters (Effective January, 2022)</b>				
4107 4019 54	Unit Kit, Basic Service Kit A, 1.5 - 2 Hp	1 per pump	1.5 - 2 Hp	HEPA Inlet filter element, Exhaust filter with O-ring, Cover gasket
4107 4020 84	Unit Kit, Basic Service Kit B, 3 - 5 Hp	1 per pump	3 - 5 Hp <sup>1</sup>	HEPA Inlet filter element, Exhaust filter with O-ring, Cover gasket
4107 4018 85	Unit Kit, Basic Service Kit C, 5 Hp (RA0155)	1 per pump	5 Hp <sup>3</sup>	HEPA Inlet filter element, Exhaust filter with O-ring, Cover gasket
4107 4001 86	Unit Kit, Basic Service Kit C, 5 - 10 Hp	1 per pump	5 - 10 Hp <sup>2</sup>	HEPA Inlet filter element, Exhaust filter with O-ring, Synthetic baffle strainer, Cover gasket
4107 4001 87	Unit Kit, Basic Service Kit D, 15 - 25 Hp	1 per pump	15 -25 HP	HEPA Inlet filter element, Exhaust filter, (2) Synthetic baffle strainers, Cover gasket
<b>2-Year Extended Service Kits</b>				
4107 4002 30	Unit Kit, Extended Service Kit, Size A	1 per pump	1.5 - 2 Hp	Coupling insert
4107 4002 31	Unit Kit, Extended Service Kit, Size B	1 per pump	3 Hp	Coupling insert
4107 4002 32	Unit Kit, Extended Service Kit, Size C	1 per pump	5 Hp <sup>1</sup>	Coupling insert
4107 4018 80	Unit Kit, Extended Service Kit, Size D	1 per pump	5 Hp <sup>3</sup>	Coupling insert
4107 4002 33	Unit Kit, Extended Service Kit, Size D	1 per pump	5 - 7 Hp <sup>2</sup>	Coupling insert
4107 4002 34	Unit Kit, Extended Service Kit, Size E	1 per pump	10 Hp	Coupling insert
4107 4002 35	Unit Kit, Extended Service Kit, Size F	1 per pump	15 - 20 Hp	Coupling insert
4107 4002 36	Unit Kit, Extended Service Kit, Size G	1 per pump	25 Hp	Coupling insert

## 7.0 Replacement / Maintenance Parts

**Notes:**

1. 5 Hp pump model RC0101 and RA0100. Incorporated into horizontal tankmount system designs.
2. 5 Hp pump model RC0155. Incorporated into basemount system design.
3. 5 Hp pump model RA0155. Incorporated into basemount system design.

KIT NUMBER	DESCRIPTION	QTY	WHERE USED	CONTENTS
<b>500 Hour Oil Change Kits<sup>1</sup></b>				
4107 4001 90	Unit Kit, 500 Hour Oil Change A	1 per pump	1.5 - 2 Hp	Oil Filter, Vacuum Oil (Mineral)
4107 4001 91	Unit Kit, 500 Hour Oil Change B	1 per pump	3 - 5 Hp <sup>3</sup>	Oil Filter, Vacuum Oil (Mineral)
4107 4019 03	Unit Kit, 500 Hour Oil Change C	1 per pump	5 Hp <sup>5</sup>	Oil Filter, Vacuum Oil (Mineral)
4107 4001 92	Unit Kit, 500 Hour Oil Change C	1 per pump	5 - 10 Hp <sup>4</sup>	Oil Filter, Vacuum Oil (Mineral)
4107 4001 93	Unit Kit, 500 Hour Oil Change D	1 per pump	15 Hp	Oil Filter, Vacuum Oil (Mineral)
4107 4001 94	Unit Kit, 500 Hour Oil Change E	1 per pump	20 - 25 Hp	Oil Filter, Vacuum Oil (Mineral)
<b>2,000 Hour Oil Change Kits<sup>2</sup></b>				
4107 4001 95	Unit Kit, 2,000 Hour Oil Change A	1 per pump	1.5 - 2 Hp	Oil Filter, Vacuum Oil (Synthetic)
4107 4001 96	Unit Kit, 2,000 Hour Oil Change B	1 per pump	3 - 5 Hp <sup>3</sup>	Oil Filter, Vacuum Oil (Synthetic)
4107 4018 84	Unit Kit, 2,000 Hour Oil Change C	1 per pump	5 Hp <sup>5</sup>	Oil Filter, Vacuum Oil (Synthetic)
4107 4001 97	Unit Kit, 2,000 Hour Oil Change C	1 per pump	5 - 10 Hp <sup>4</sup>	Oil Filter, Vacuum Oil (Synthetic)
4107 4001 98	Unit Kit, 2,000 Hour Oil Change D	1 per pump	15 Hp	Oil Filter, Vacuum Oil (Synthetic)
4107 4001 99	Unit Kit, 2,000 Hour Oil Change E	1 per pump	20 - 25 Hp	Oil Filter, Vacuum Oil (Synthetic)

**Notes:**

1. All units ship with mineral oil, which requires changing every 500 hours.
2. Synthetic oil is available for the units and using synthetic oil can extend the oil change interval from 500 to 2,000 hours.
3. 5 Hp pump model RC0101 and RA0100. Incorporated into horizontal tankmount system designs.
4. 5 Hp pump model RC0155. Incorporated into basemount system designs.
5. 5 Hp pump model RA0155. Incorporated into basemount system designs.

## 7.0 Replacement / Maintenance Parts

### 7.2 Retrofit Kits for HEPA Filters

KIT NUMBER	DESCRIPTION	QTY	WHERE USED	CONTENTS
<b>KIT - Retrofit HEPA Filter Lube Vertical, Horizontal, SPC &amp; Modular</b>				
4107 4018 95	KIT - Retrofit HEPA Filter Lube 120G Horizontal SPC	1 per pump	1.5-2Hp DX	(1) Filter assembly (1) Drain flask assembly (1) 1/4" Bleed Valve
4107 4018 96	KIT - Retrofit HEPA Filter Lube 80G Horizontal SPC	1 per pump	1.5-2Hp DX	(1) Filter assembly (1) Pipe nipple (1) Drain flask assembly (1) 1/4" Bleed Valve
4107 4018 97	KIT - Retrofit HEPA Filter Lube 120G Horizontal SPC	1 per pump	3-5Hp DX	(1) Filter assembly (2) Pipe nipple (1) Drain flask assembly (1) 1/4" Bleed Valve
4107 4018 98	KIT - Retrofit HEPA Filter Lube 200G Horizontal SPC	1 per pump	3-5Hp DX	(1) Filter assembly (2) Pipe nipple (1) Drain flask assembly (1) 1/4" Bleed Valve
4107 4018 99	KIT - Retrofit HEPA Filter Lube 30G Vertical SPC	1 per pump	1.5-2HP DX	(1) Filter assembly (1) Drain flask assembly (1) 1/4" Bleed Valve
4107 4019 00	KIT - Retrofit HEPA Filter Lube 60G Vertical SPC	1 per pump	3Hp DX	(1) Filter assembly (2) Pipe nipples (1) Drain flask assembly (1) 1/4" Bleed Valve
4107 4019 02	KIT - Retrofit HEPA Filter Lube Modular	1 per pump	5Hp MODULAR DX TX QX 5HP SPC DX-TX & TX 5HP 60G VERTICAL DX	(1) Filter assembly (1) Pipe nipple (1) Drain flask assembly (1) 1/4" Bleed Valve
4107 4019 08	KIT - Retrofit HEPA Filter Lube SPC	1 per pump	5Hp DX, TX-QX & QX	(1) Filter assembly (2) Pipe nipples (1) Drain flask assembly (1) 1/4" Bleed Valve

## 7.0 Replacement / Maintenance Parts

KIT NUMBER	DESCRIPTION	QTY	WHERE USED	CONTENTS
<b>KIT - Retrofit HEPA Filter Lube Vertical, Horizontal, SPC &amp; Modular</b>				
4107 4021 22	KIT - Retrofit HEPA Filter Lube Vertical, Modular & SPC	1 per pump	7.5Hp Modular DX TX QX 7.5HP SPC DX-TX & TX 7.5HP 60G Vertical DX	(1) Filter assembly (1) Drain flask assembly (1) 1/4" Bleed Valve
4107 4019 09	KIT - Retrofit HEPA Filter Lube SPC	1 per pump	7.5Hp DX, TX-QX & QX	(1) Filter assembly (1) Pipe nipples (1) Drain flask assembly (1) 1/4" Bleed Valve
4107 4019 10	KIT - Retrofit HEPA Filter Lube Modular	1 per pump	10Hp Modular DX TX QX 10HP SPC DX, TX-QX & QX	(1) Filter assembly (1) Pipe nipples (1) Drain flask assembly (1) 1/4" Bleed Valve
4107 4019 11	KIT - Retrofit HEPA Filter Lube SPC	1 per pump	10Hp DX-TX & TX	(1) Filter assembly (2) Pipe nipples (1) Drain flask assembly (1) 1/4" Bleed Valve
4107 4019 14	KIT - Retrofit HEPA Filter Lube SPC	1 per pump	15-25HP All Systems	(1) Filter assembly (1) Drain flask assembly (1) 1/4" Bleed Valve

<b>Retrofit HEPA Filter Horizontal Tank Mount Bypass Kit</b>				
4107 4019 15	Retrofit HEPA Filter Horizontal Tank Mount Bypass	1 per tank	1.5-2HP 120G All 80 & 200 G Systems	(2) Pipe nipples (2) 45 degree elbows

## 7.3 PPE Kit for Filter Service

KIT NUMBER	DESCRIPTION	QTY	WHERE USED	CONTENTS
4107 4018 65	KIT - Filter Service PPE	1	As needed	(1) Coverall (1) N100 Respirator (1) Safety glasses (2) Biohazard bags

## 8.0 Maintenance Record

Model Number \_\_\_\_\_

Serial Number \_\_\_\_\_

Installation Date \_\_\_\_\_

Date of Service								
Hours								
Load								
Ambient Temp.								
Vacuum Level								
Inlet Filters								
Inlet Screen								
Oil Change								
Oil Filter								
Motor Bearings								
Coupling Inserts								
Exhaust Filters								
Relief Valves								
Misc.								
Serviced By								

## 8.0 Maintenance Record

Model Number \_\_\_\_\_

Serial Number \_\_\_\_\_

Installation Date \_\_\_\_\_

Date of Service								
Hours								
Load								
Ambient Temp.								
Vacuum Level								
Inlet Filters								
Inlet Screen								
Oil Change								
Oil Filter								
Motor Bearings								
Coupling Inserts								
Exhaust Filters								
Relief Valves								
Misc.								
Serviced By								

# Appendix A: TotalAlert 360 Control System

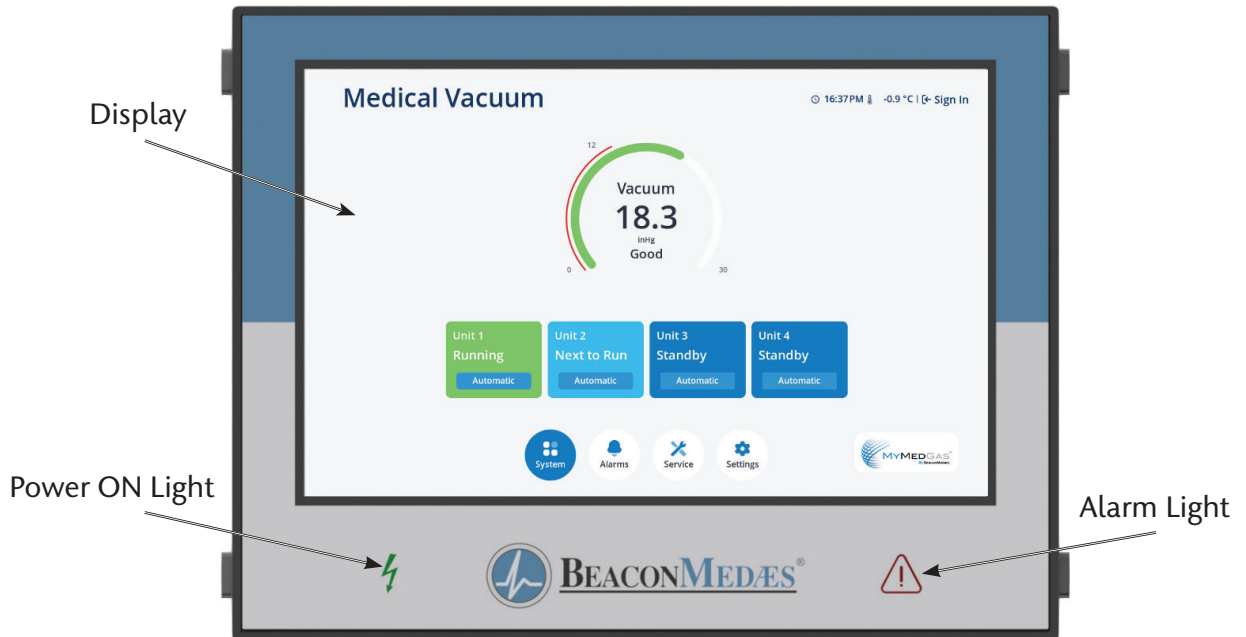
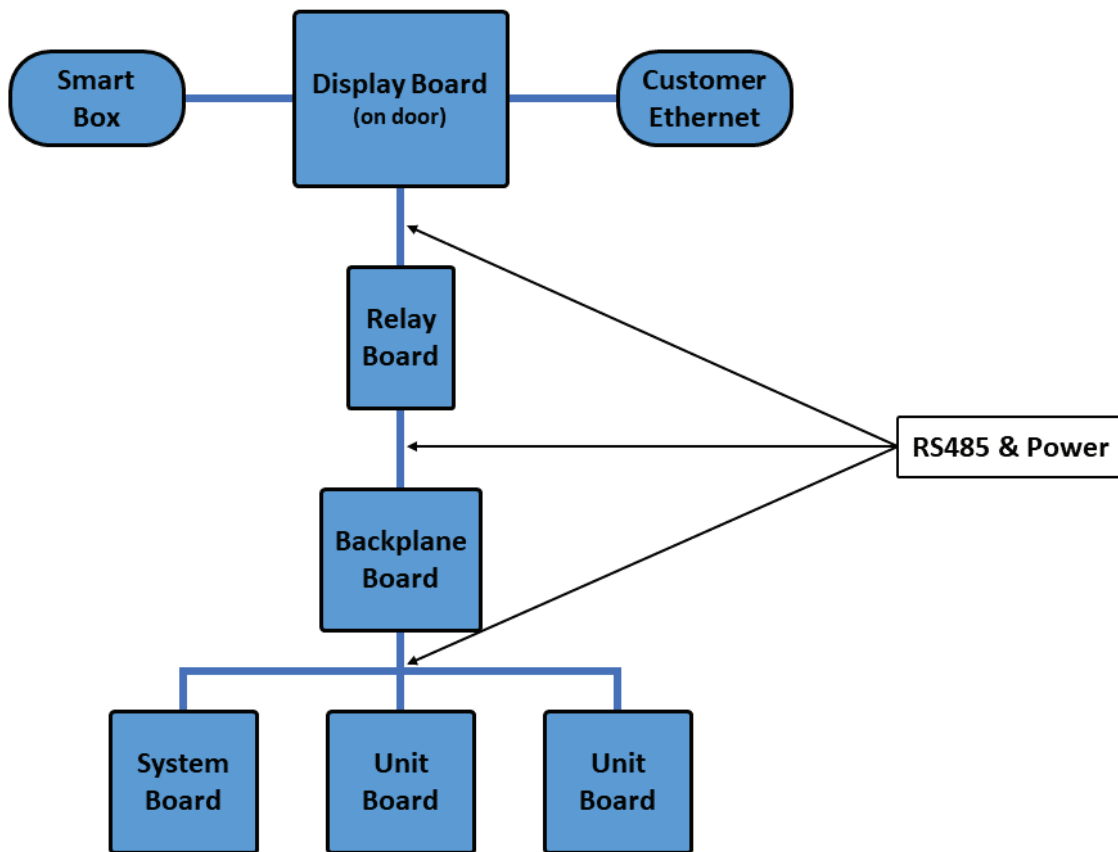


Figure A.1 Touchscreen Controls



All Boards Other than Display Board Mounted on Back Panel

Figure A.2 Duplex Medical Vacuum Configuration - Printed Circuit Boards

## Appendix A: TotalAlert 360 Control System

### A.1 Board Configurations

The source control system is comprised of five (5) different printed circuit boards (PCBs) with interconnecting wiring (RS485) for internal communications between the boards. See Figure A.2. NOTE: The system and unit controller boards are the same printed circuit board with different settings distinguishing them.

1. Display Board for 10.1" Touch Screen Display
2. Relay Board
3. Backplane Board
4. Control Board for System or Unit

In a standard medical vacuum duplex system, the PCB configuration consists of the following quantities and types of boards:

- (1) Display Board
- (1) Relay Board
- (1) Backplane Board
- (1) System Control Board
- (2) Unit Control Boards

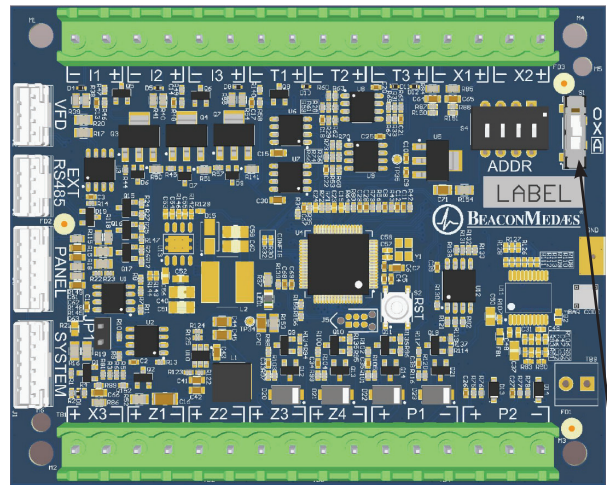
In a standard medical vacuum quadruplex system, the PCB configuration consists of the following quantities and types of boards:

- (1) Display Board
- (1) Relay Board
- (2) Backplane Board
- (1) System Control Board
- (4) Unit Control Boards

### A.2 Manual Override

During the system startup, the manual override switch, located on the unit board, is utilized to ensure the unit is in the off position. The manual override switch on the unit board is a safety measure as well, for emergency situations to ensure the pump unit produces medical vacuum.

In an emergency where the control system is not operating effectively, the manual override switch can be moved from the Automatic position to the Manual position. See Figure A.2.1. Moving to this position forces the pump to run continuously.



Manual Override Switch

- O - On Manual
- X - Off
- A - Automatic

*Unit Board with Manual Override Switch*

**Figure A.2.1 Manual Override**

If the switch is in Manual or Off position on the unit board, the touchscreen controls no longer control the vacuum pump. Moving the switch back to the Automatic position puts the unit under the control of the TotalAlert 360 control system.



## Appendix A: TotalAlert 360 Control System

**CAUTION:** The “Manual Override” mode of operation should only be used for emergencies such as a loss of the display touchscreen and should not be used for normal operation.

### A.3 10.1” Display Controller

#### A.3.1 Basic Software Architecture

The primary purpose of the display board is to drive the 10.1” LCD display. Its other functions include the following:

1. Communicate through the relay board and backplane board via RS485 bus to relay commands from the touch screen to the system and unit boards.
2. Display messages from the system and unit boards.
3. Interface to the 10.1” Display touch screen to interpret the user interaction.
4. Evaluate alarm signals.
5. Accept new firmware via the USB connection when connected to a system programmer configured with genuine **BEACONMEDÆS** software for reprogramming.

#### A.3.2 User Interface for Source Systems



Figure A.3.2.1 Main Screen

The user interface is displayed on a 10.1” 1280 x 800 pixel display as shown in Figure A.3.2.1. The interface is designed such that any information can be accessed with a minimal amount of touches by the user.

The 10.1” screen is divided into two main areas – the top portion above the toolbar which changes depending on the icon selected on the toolbar and bottom portion which contains the toolbar (Figure A.3.2.2) and is available on most screens.

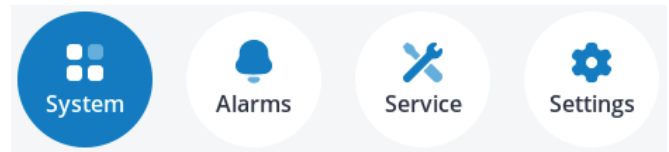


Figure A.3.2.2 Screen Toolbar

#### A.3.3 System (Main) Screen

The system (main) screen (Figure A.3.2.1) shows the pertinent system measurements as well as unit sequence information.

The pertinent system measurement vacuum level. Pressing a pertinent system data gauge shows Trend information for that value. See Figure A.3.4.1.

The Unit Button (Figure A.3.3.1) shows unit, status, and mode.

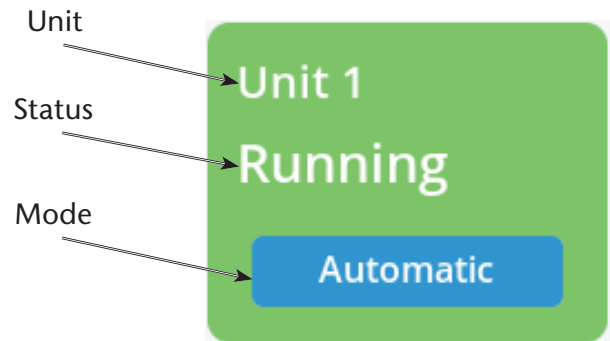


Figure A.3.3.1 Unit Button

## Appendix A: TotalAlert 360 Control System

Mode Label	Mode Color	Status Label	Button Color
Automatic	Blue	Running	Green
		Next to Run	Lt. Blue
		Standby	Blue
Manual	Orange	Running	Orange
		Standby	Yellow
Off	Red	Stopped	Red
Override ON	Red	Running	Orange
Override OFF	Red	Stopped	Red
Emergency COM	Red	No Comms	Red
Expandable	Gray	Unavailable	White

**Table A.3.3.1 Unit Mode & Status Configurations**

Table A.3.3.1 shows the possible combinations of mode and status for a given unit. In regards to the lag alarm condition, a unit is only considered available when the mode is Automatic and the status is either Next to Run or Standby. All other combinations result in the unit being considered unavailable.

- In Automatic, the unit will start/stop depending on the vacuum level and unit sequencing.
- In Manual, the unit will start/stop based on vacuum readings from the backup vacuum switch.
- In Off, the unit is stopped and will not run.
- In Override ON, the unit will run continuously.
- In Override OFF, the unit is stopped and will not run.
- In Emergency COM, communication between the controls and the unit has been disrupted. If a connection to the backup vacuum switch is intact, the unit will start/stop based on vacuum readings from the backup vacuum switch. Otherwise, the unit will not run.

- In Expandable, the unit does not exist but can be added to the system.

### A.3.4 Trend Screen



**Figure A.3.4.1 Trend Screen**

The trend screen (Figure A.3.4.1) shows the measured value over a specific time period:

- The default time period when opening the window is the last 60 minutes. For a given period, the maximum amount of data stored will only be for the most recent time period and the older data will be removed from view and memory.
- Another time period is selected by pressing the buttons above the trend chart. These periods are 60 minutes (600 data points – 0.1 min resolution), 6 hours (600 data points – 0.6 min resolution), 24 hours (600 data points – 2.4 min resolution) and 6 days (600 data points – 14.4 min resolution).
- There is an export button available underneath the gauge. When the export button is pressed, the data will be stored on the display board until it is transferred to a computer (If the system turns off, the export file will be lost). This transfer will require an USB-A to USB-A cable. Only one file can be stored on the display board at a time. If exporting multiple files, transfer each file before exporting the next file.

# Appendix A: TotalAlert 360 Control System

## A.3.5 Unit Screen

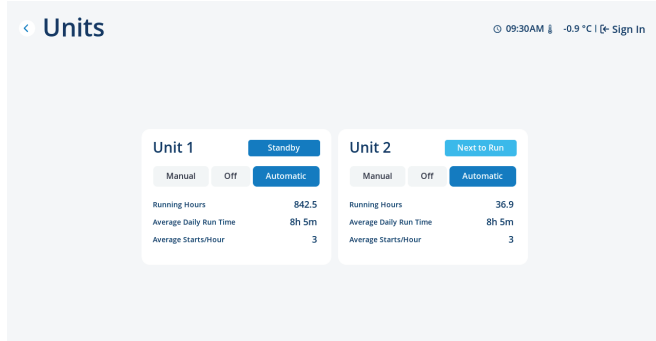


Figure A.3.5.1 Unit Screen

The unit screen (Figure A.3.5.1) shows the operation mode and status of each unit along with running hours, average daily run time, and average starts per hour:

- Mode: Automatic (Blue), Manual (Orange), Off (Red), Override ON (Red), and Override OFF (Red). Automatic, Manual, and Off can be selected from the display. The override modes are set using the switch on the unit controller boards (Figure A.2.1), but will be shown on the display. If in an override mode, no other selection can be made using the display.

## A.3.6 Units Usage

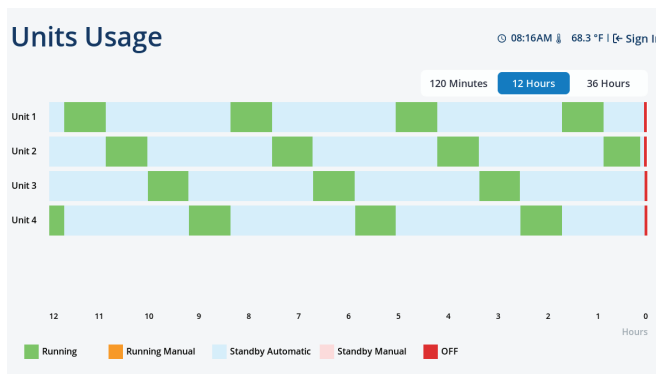


Figure A.3.6.1 Units Usage

The Units Usage screen (Figure A.3.6.1) can be accessed by selecting the button to the right of the toolbar on the Units screen. Once on the Units Usage screen, the user can view three different time intervals (120 minutes, 12 hours, and 36 hours) by using the buttons at the top right of the chart. The chart shows the running status of each unit during the selected time interval.

## A.3.7 Alarms Screen

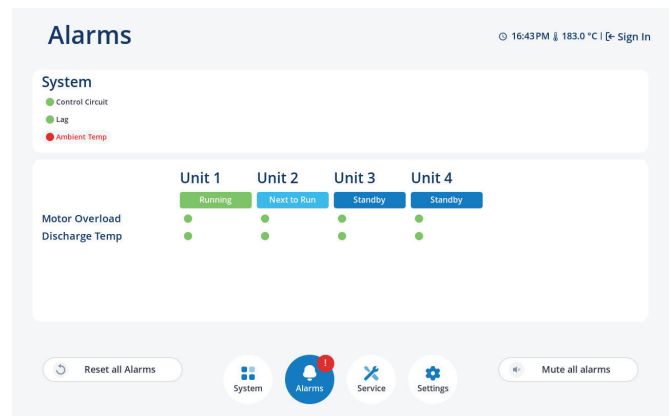


Figure A.3.7.1 Alarms Screen

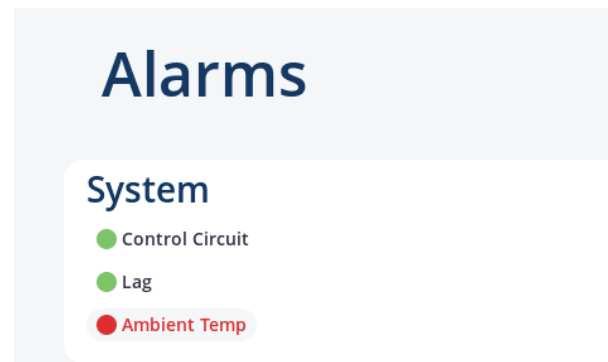


Figure A.3.7.2 System Alarm

# Appendix A: TotalAlert 360 Control System



Figure A.3.7.3 Unit Alarm



Figure A.3.7.4 Unit Shutdown

The alarms screen (Figure A.3.7.1) shows all of the system alarm and shutdown information. An alarm is classified as an event of significance that does not shut the system down. These alarms are latched and are not cleared until a user presses the reset button on the alarms screen and enters their initials. This reset button will reset all alarms for that given system. A shutdown is classified as an event of significance that shuts the unit down. Shutdown events are latched and are not cleared until the condition is corrected and a user presses the reset button on the alarms screen and enters their initials.

- Green condition indicates a normal status for that condition.
- Red condition indicates an abnormal status for that condition. The icon will be labelled “Alarm” or “Shutdown” as applicable.
- The horn silence button is at the bottom right of the screen.
- if the user is signed into the system, the initials associated with that account will automatically be entered in the event log when resetting an alarm. TC for technician, AD for admin, and any custom initials set up for established users. If not signed into the system, users will be prompted to enter their initials.

## A.3.8 Service Screen

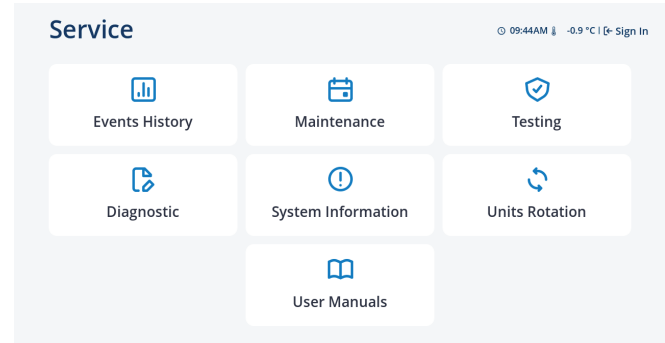


Figure A.3.8.1 Service Screen

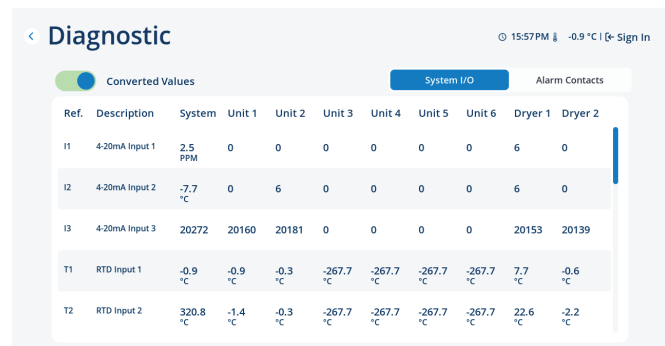


Figure A.3.8.2 Diagnostic Screen

The service screen (Figure A.3.8.1) allows the selection of various sub screens:

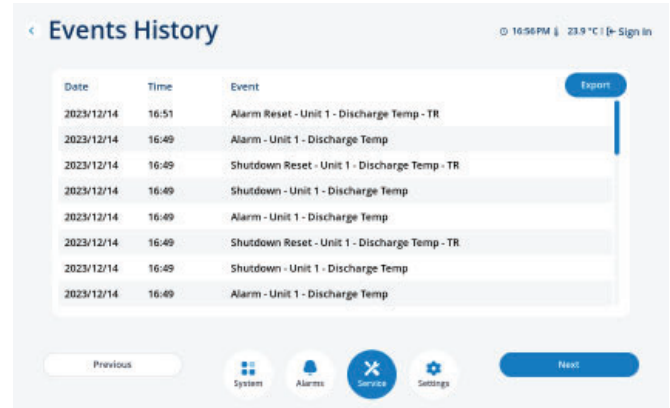
- Events History – Displays a log of all recorded events. Data can be exported.
- Maintenance – Additional screens depicting suggested and required maintenance items with resettable timers. When maintenance is due, both the maintenance button and the service icon on the tool bar will have a red (!) symbol. See Section A.3.10 for more information.
- Testing – Allows the user to test all alarm events. See Section A.3.11 for more information.
- Diagnostic – Two tabs depicting the I/O status of the connecting unit controller board. The

## Appendix A: TotalAlert 360 Control System

first tab (Figure A.3.8.2) lists the digital inputs (X1-X3 as 0 or 1), the analog readings (T1-T3, I1-I3, and P1-P2 with A/D values), the 24VDC powered digital outputs (Z1-Z4 as 0 or 1), as well as the statuses of “Fan Enable (Off/On)”, “Backup Switch (Open/Closed)”, and “Override Switch (On/Off/No)”. The values on the first tab can be displayed in their raw state as described above or as converted values changed into their corresponding units of measurement (Note: Values from disconnected I/Os may also convert, but these converted values are incorrect and should be ignored). The second tab lists alarm contacts as “Open” or “Closed”. “Open” contacts are in alarm state.

- System information – Displays the system serial and model numbers, wiring diagram number, system warranty level, ship date, startup date and person, as well as service contact number. Also contains software version.
- Units Rotation – Allows the user to run the unit for a short period to check rotation. Arrows located on the belt guard show the correct rotation direction (counter clockwise when facing the compressor pulley). Unit mode must be Off to test rotation.
- User Manuals – Contains a QR code that directs to the user manual for the system.

### A.3.9 Events History Screen



**Figure A.3.9.1 Events History Screen**

The Events History screen (Figure A.3.9.1) shows all of the system and unit event history excluding service maintenance history.

- Events are shown in descending date/time order. Located at the bottom of the screen to either side of the toolbar are buttons for navigating between pages. The maximum number of events is 200.
- There is an export button available at the top right of the table. When the export button is pressed, the data will be stored on the display board until it is transferred to a computer. This transfer will require an USB-A to USB-A cable. Only one file can be stored on the display board at a time. If exporting multiple files, transfer each file before exporting the next file.

## Appendix A: TotalAlert 360 Control System

### A.3.10 Maintenance Screens

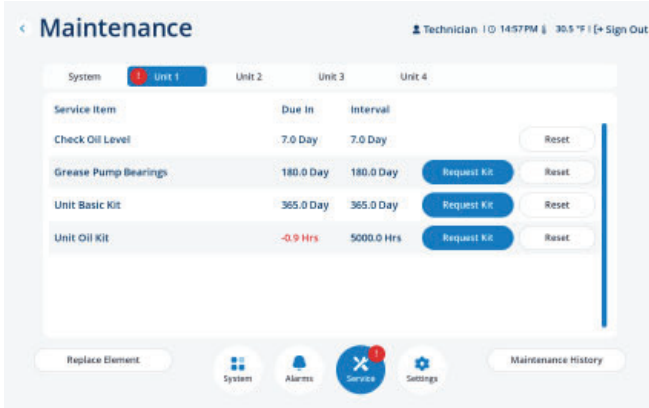


Figure A.3.10.1 Unit Maintenance Screen

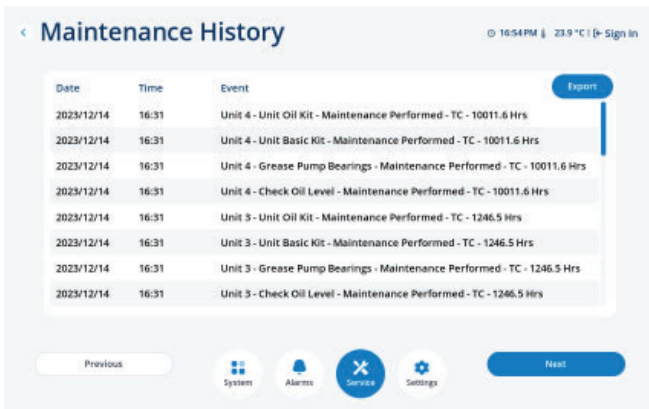


Figure A.3.10.2 Maintenance History Screen

The maintenance screens (Figures A.3.10.1&2) are accessed via the service screen:

- Multiple screens depicting maintenance items with resettable timers. If an item is past due the “Due In” column value will turn red and the service icon and appropriate tab will have a red (!) symbol.
- The first (default) tab shows the system maintenance. The other tabs across the top of the screen allow the user to access unit maintenance pages. When the user resets a timer, the action is logged in the service history.
- By selecting the Request Kit button, the user

will be taken to a page with a QR code to access the kit information.

- After a service activity is performed, press the Reset button next to the appropriate service item and enter the users initials. If signed in, the users initials will be entered automatically.
- The Replace Element button to the left of the toolbar will reset all of the maintenance timers for the active page. The user must be signed in to use this function.
- Maintenance history is accessed by pressing the button to the right of the toolbar on the Maintenance screen. Once on the Maintenance History screen, the user will have the ability to navigate between pages using buttons on either side of the toolbar. Additionally, the user can either clear the history (with technician level access) or export the data using buttons at the top right of the table. When the export button is pressed, the data will be stored on the display board until it is transferred to a computer (If the system turns off, the export file will be lost). This transfer will require a USB-A to USB-A cable. Only one file can be stored on the display board at a time. If exporting multiple files, transfer each file before exporting the next file.

### A.3.11 Testing Alarms

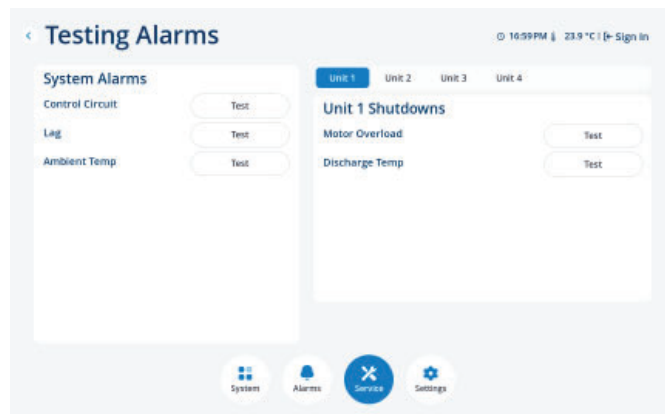


Figure A.3.11.1 Testing Alarms Screen



## Appendix A: TotalAlert 360 Control System

In the Service section of the Main screen and Unit screens, the operator can test each alarm and shutdown event. When an alarm/shutdown event is selected to test, the actual alarm/shutdown is latched. At this point, the system responds as if an actual alarm/shutdown has occurred.

**CAUTION:** If testing a shutdown event, the pump being tested will shut down. Notify the appropriate hospital personnel **BEFORE** testing any alarms.

For an alarm/shutdown event, the following will occur:

- Unit shuts down (shutdown event only).
- The horn will initiate.
- Alarms screen will show the alarm/shutdown condition.
- An alarm/shutdown signal will be sent to the Master alarms.
- The operator must respond and reset the alarm/shutdown signal by pressing the “Reset all Alarms” button on the Alarms screen.
- A history item will be created that shows the “Test” alarm/shutdown event and a subsequent event for the correction of the “Test” item.

**CAUTION:** When testing a Shutdown condition, the pump shuts down and must be restarted after the test. Press Automatic on the Unit main screen.

### A.3.12 Settings Screen

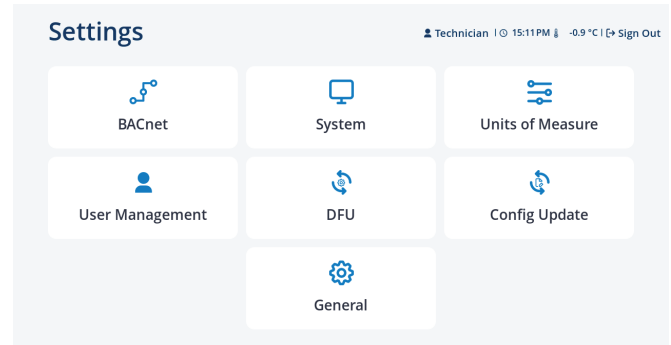


Figure A.3.12.1 Settings Screen

The settings screen (Figure A.3.12.1) allows the selection of various sub screens that pertain to system configuration data. All value/adjustment changes are password protected.

- BACnet – Displays BACnet connection information and settings. See Section A.5 for more information.
- System – Allows the adjustment of system vacuum operating range.
- Units of Measure – Allows changing units of measurement displayed by the system.
- General – Allows adjustment of horn reinitialization timer, system language, and date and time as well as activation of the backlight timer.

*The below option is only available when signed in as a technician or admin.*

- User Management – Allows user to create and manage user profiles.

*The below options are only available when signed in as a technician.*

- DFU – Reboots system in DFU mode.

# Appendix A: TotalAlert 360 Control System

- Config Update – Allows user to update system configuration.

## A.4 User Access



Figure A.4.1 Sign In Screen

Sign In Button

The TotalAlert 360 control system can store up to five user profiles. There are three permission levels to which a profile can be assigned: technician, admin, and user. There will be one technician and one admin profile per system and up to three user profiles. The technician profile has the highest level of access followed by the admin and lastly the user. To sign in, select the “Sign In” button at the top right of the main screen. See Figure A.4.1. On this page, use the drop down to select the desired profile. It may be necessary to scroll down to find the intended profile. Then enter the correct password to sign into the selected profile.

### A.4.1 Password Items

Some system settings require the user to be signed in to change. Certain settings are only available when the user is signed in as either an admin or technician. An Admin level profile will have the ability to change the Admin level settings as well as all User level settings. A Technician level profile will have the ability to change the Technician level settings as well as all Admin and User level settings.

### User Level Settings:

- Adjust system pressure operating levels - Adjust the system operating pressure high and low levels within the min and max ranges.
- Set horn reinitialization timer - Turn the horn reinitialization timer on/off and set the timer. The horn will reinitiate at the set amount of time after being silenced.
- Test horn - Test the local alarm horn.
- Change display language - Change the language on the display.
- Change units of measure - Change the system units of measurement.
- Set date/time - Set the year, month, day and time on the display.
- Set BACnet settings - Configure settings for connecting to the BACnet system. See Section A.5 for more information.
- Turn backlight timer on/off - Turn on/off the backlight timer. Screen will dim after 15 minutes of no user input. Just touch the screen to return brightness to normal setting.
- Reset maintenance events - Reset the “Due In” timer on maintenance items.

### Admin Level Settings

- All User level settings
- Create or delete user profiles - Create or delete User level profiles for adding additional users.

### Technician Level Settings

- All User and Admin level settings
- Set maximum unit run time - Set the maximum run time for a unit before the system will cycle to the next available unit.



# Appendix A: TotalAlert 360 Control System

- Set vacuum reading offset - This offset will change the on-screen vacuum reading by the selected value. This feature is used to align the vacuum reading on the display with the gauge on the receiver. Possible values are +/-0.2, 0.4, or 0.6 inHg.
- Change number of units installed - Used to add units on an expandable system.
- Change maintenance item intervals
- Adjust vacuum min and max levels - Change set points for when units start and stop while running in Automatic mode.
- Reset events history log - Clear the events history log.
- Reset maintenance history log - Clear the maintenance history log.
- Reset user password - Reset the password for User or Admin profiles.

- Device Name
- Device ID
- IPv4
- Subnet Mask
- Gateway
- Port
- Foreign LifeTime
- Foreign IPv4
- Foreign Port

## A.5 BACnet



Figure A.5.1 BACnet Settings

This system is BACnet compatible. The user can connect to the system through the ethernet port on the top of the control cabinet. When signed in, the user can modify the following settings:

## A.6 MyMedGas

### A.6.1 Logging Daily Rounds

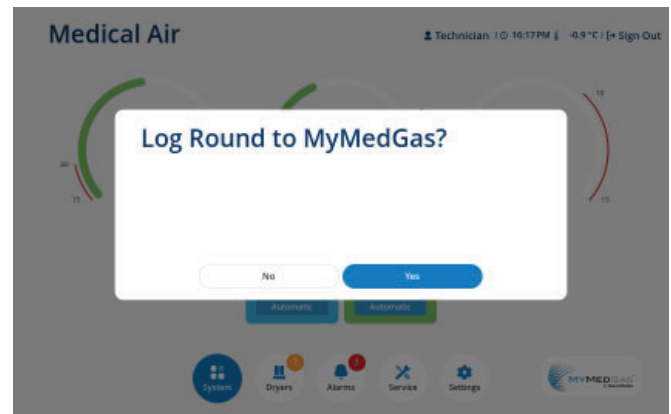


Figure A.6.1.1 Log Daily Round

The MyMedGas button at the bottom right of the main screen can be used to log a daily round to the MyMedGas system. This cellular communication is done via the SmartBox unit in the control cabinet.

### A.6.2 MyMedGas Further Information

For further information, refer to the manual for MyMedGas.







*Part of the Atlas Copco Group*

**1059 Paragon Way Rock Hill, SC 29730**

**(888) 4-MEDGAS (888) 463-3427**

**Fax (803) 817-5750**

**[www.beaconmedaes.com](http://www.beaconmedaes.com)**