





This drawing and the information contained herein remain the property of BeaconMedaes and may not be used for other than the purpose for which it is loaned without the expressed written permission from BeaconMedaes Engineering.

- Notes:
1. SYSTEM WEIGHT: 2,063 LBS.
  2.  INDICATES LIFTING POINTS
  3.  DENOTES CENTER OF GRAVITY

SYSTEM CONNECTIONS	
ID	DESCRIPTION
I	INLET LOCATION
D	DISCHARGE LOCATION
C	CONDENSATE DRAIN LOCATION
T	TANK DRAIN

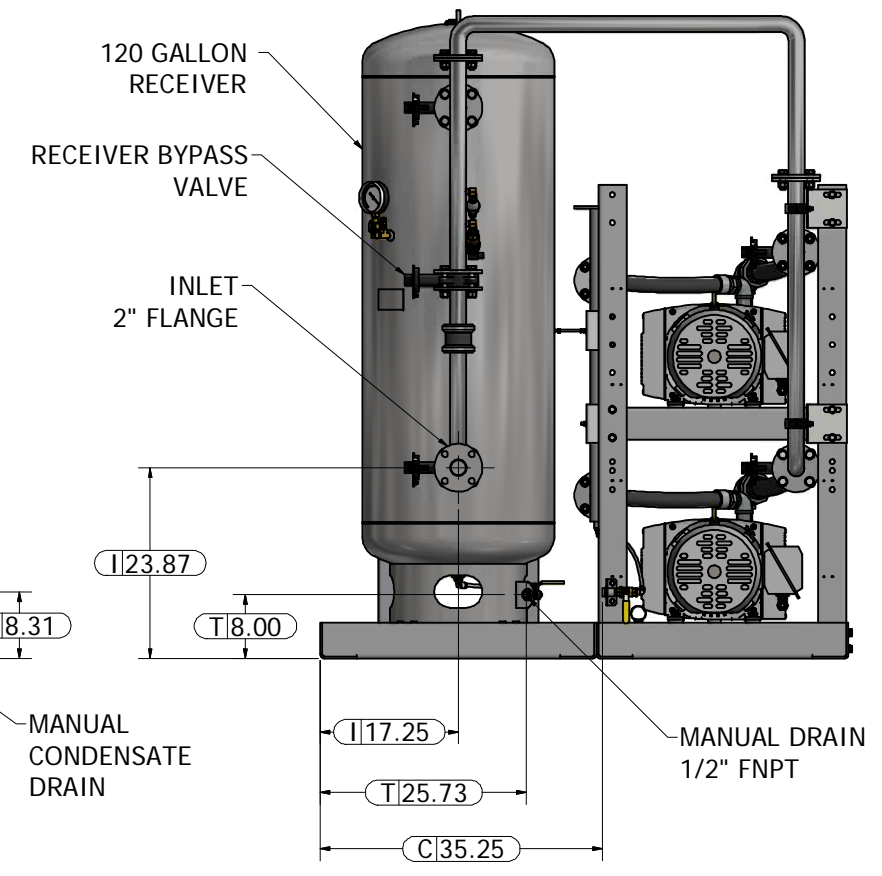
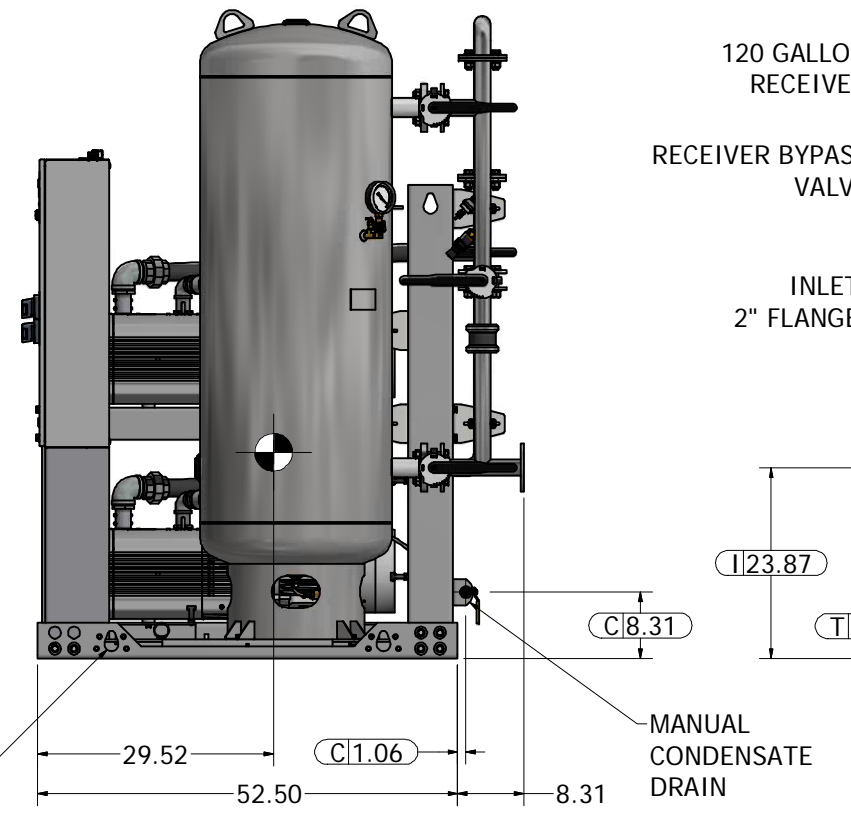
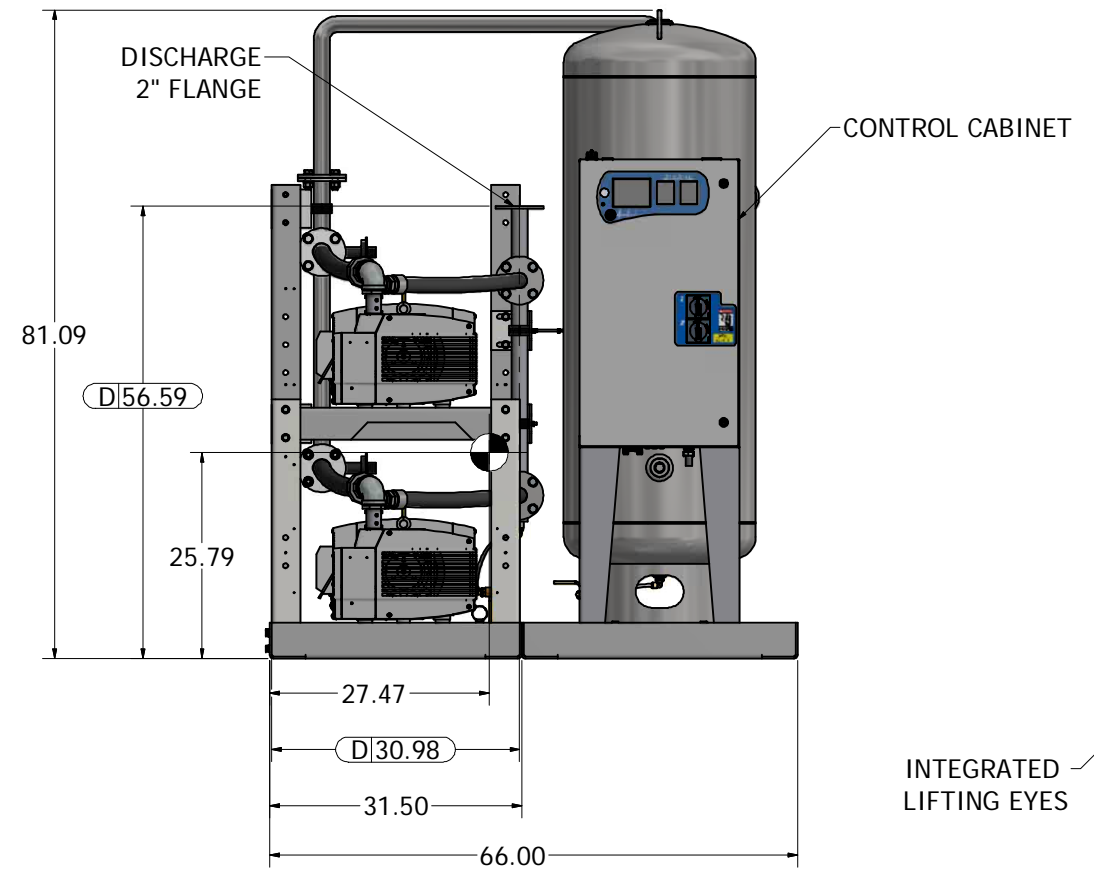
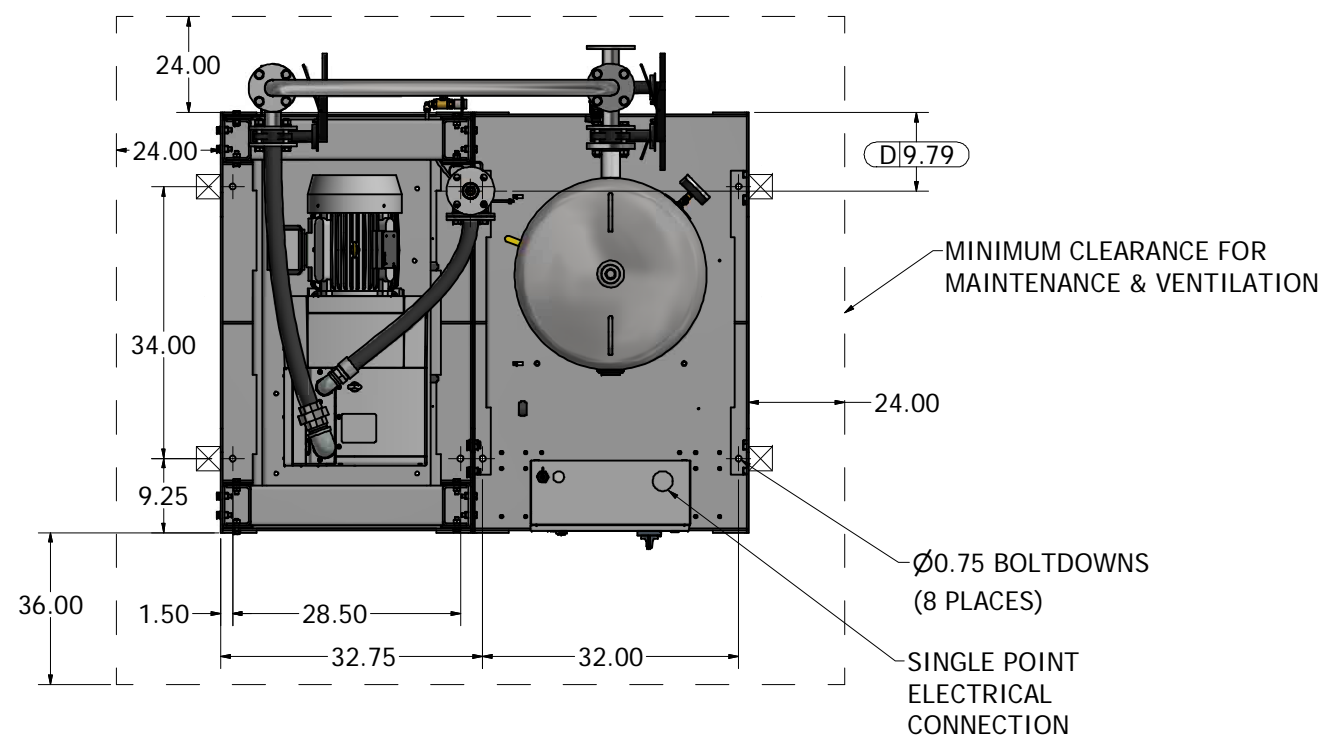

Revised: MDB	Date: 05/16/2019	Drawn: JOL	Date: 07/23/2015
		Scale: <b>D</b>	
Description: GENERAL ASSEMBLY DX 7.5HP DRY SPC V 120G TAE		Part Number: 4107 8553 32	
DN: BM190344		Rev: 02	
Sheet 1 of 1		DO NOT SCALE THIS DOCUMENT	