

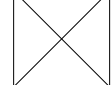
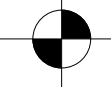
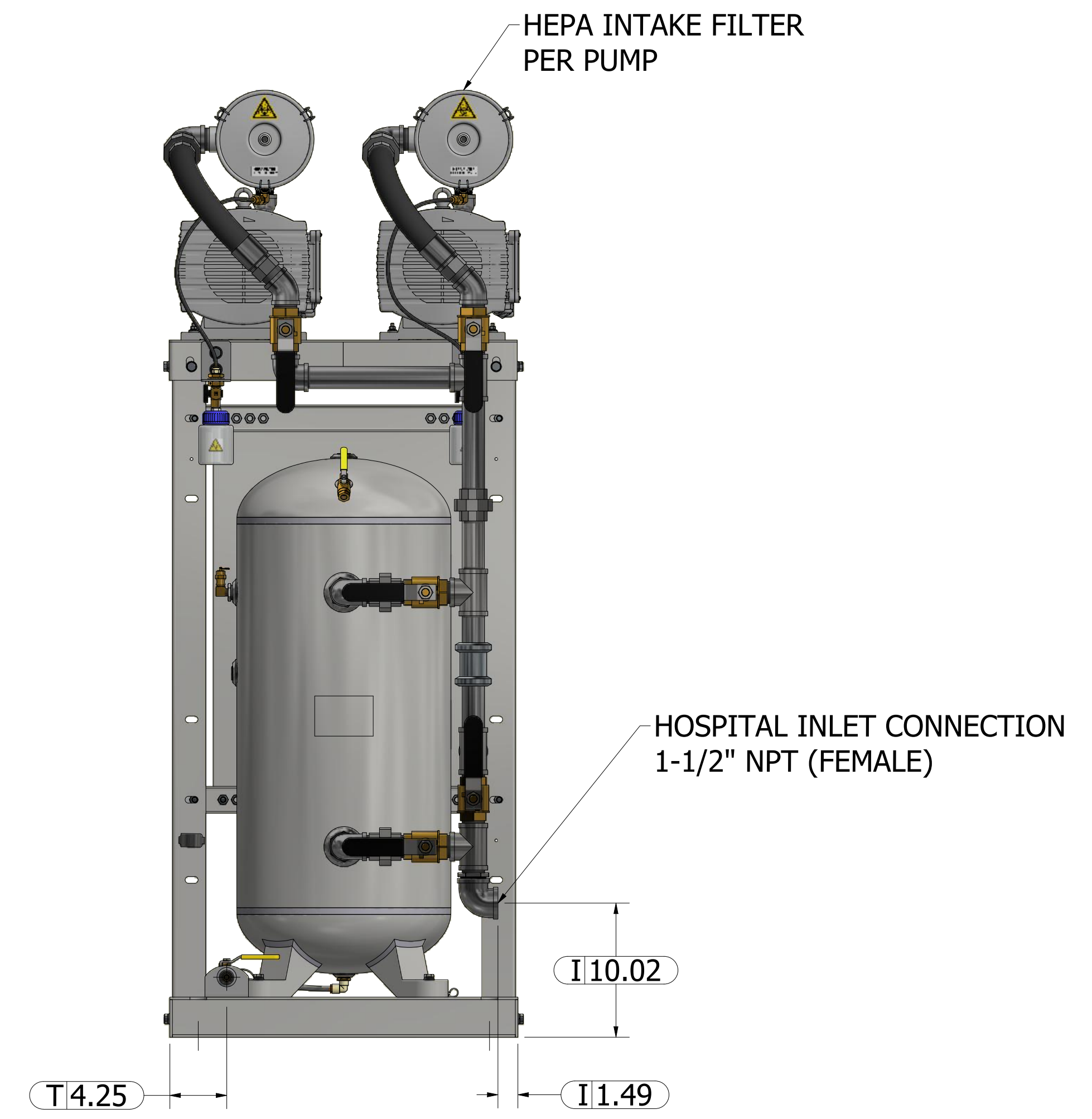
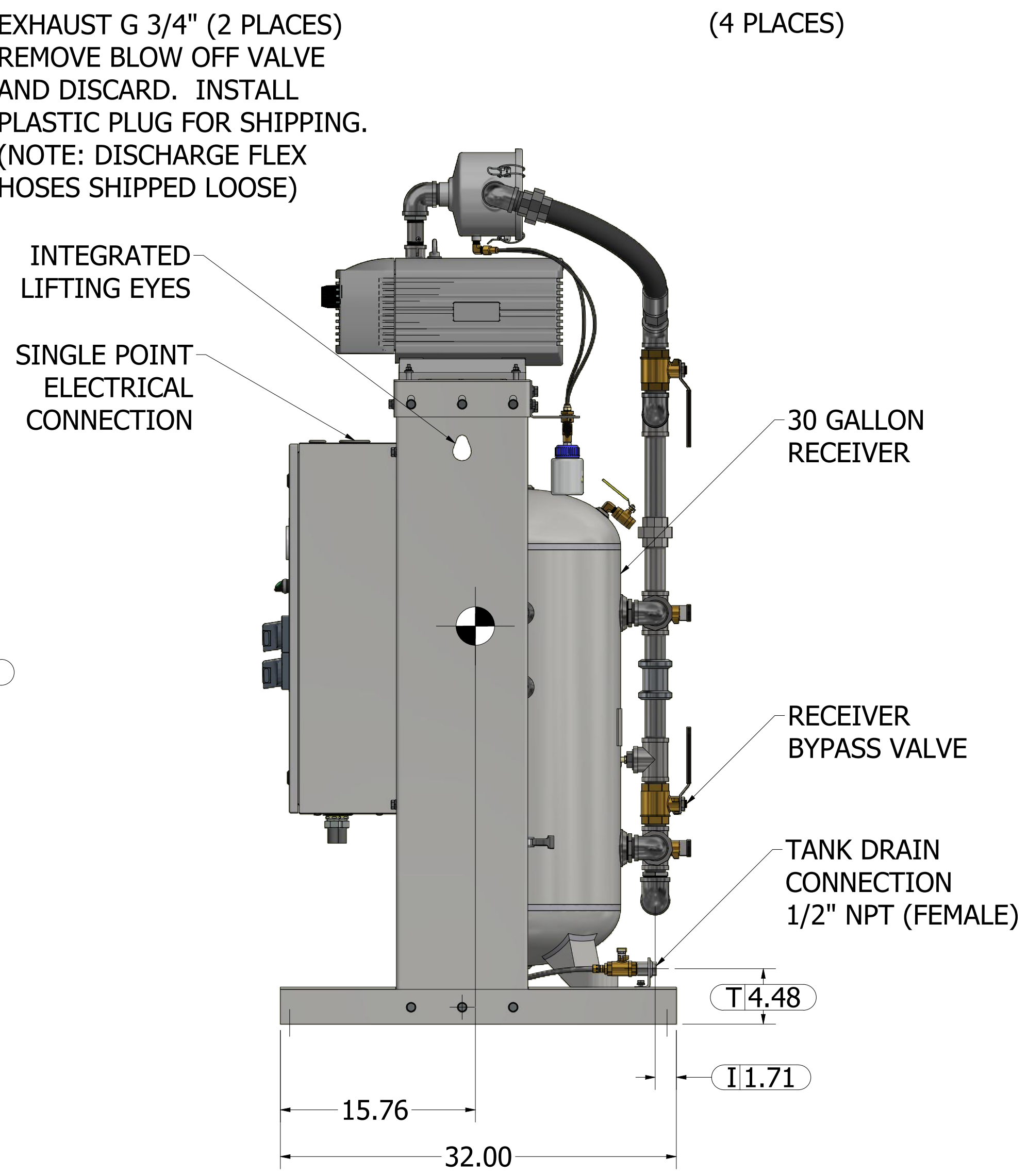
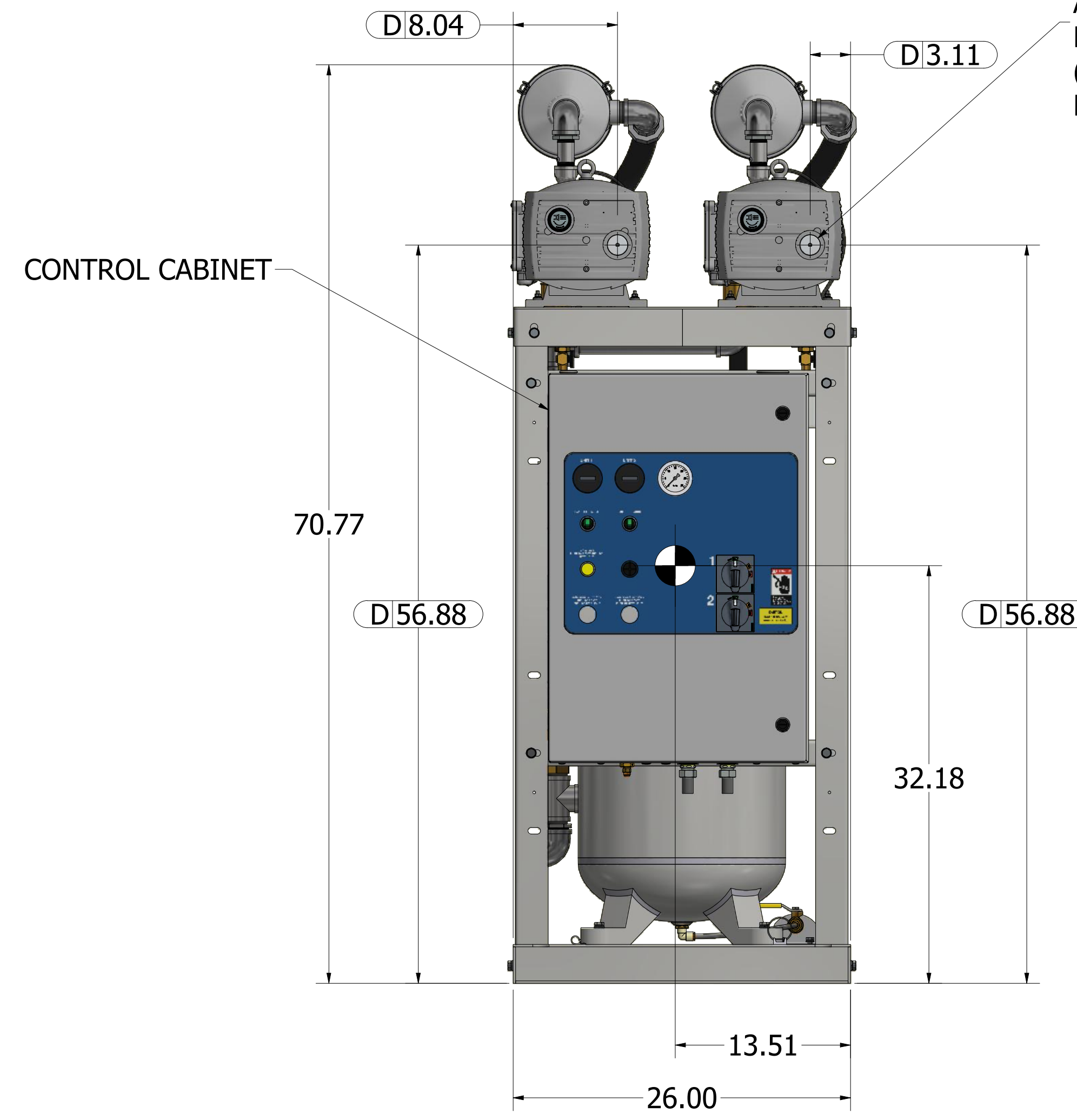
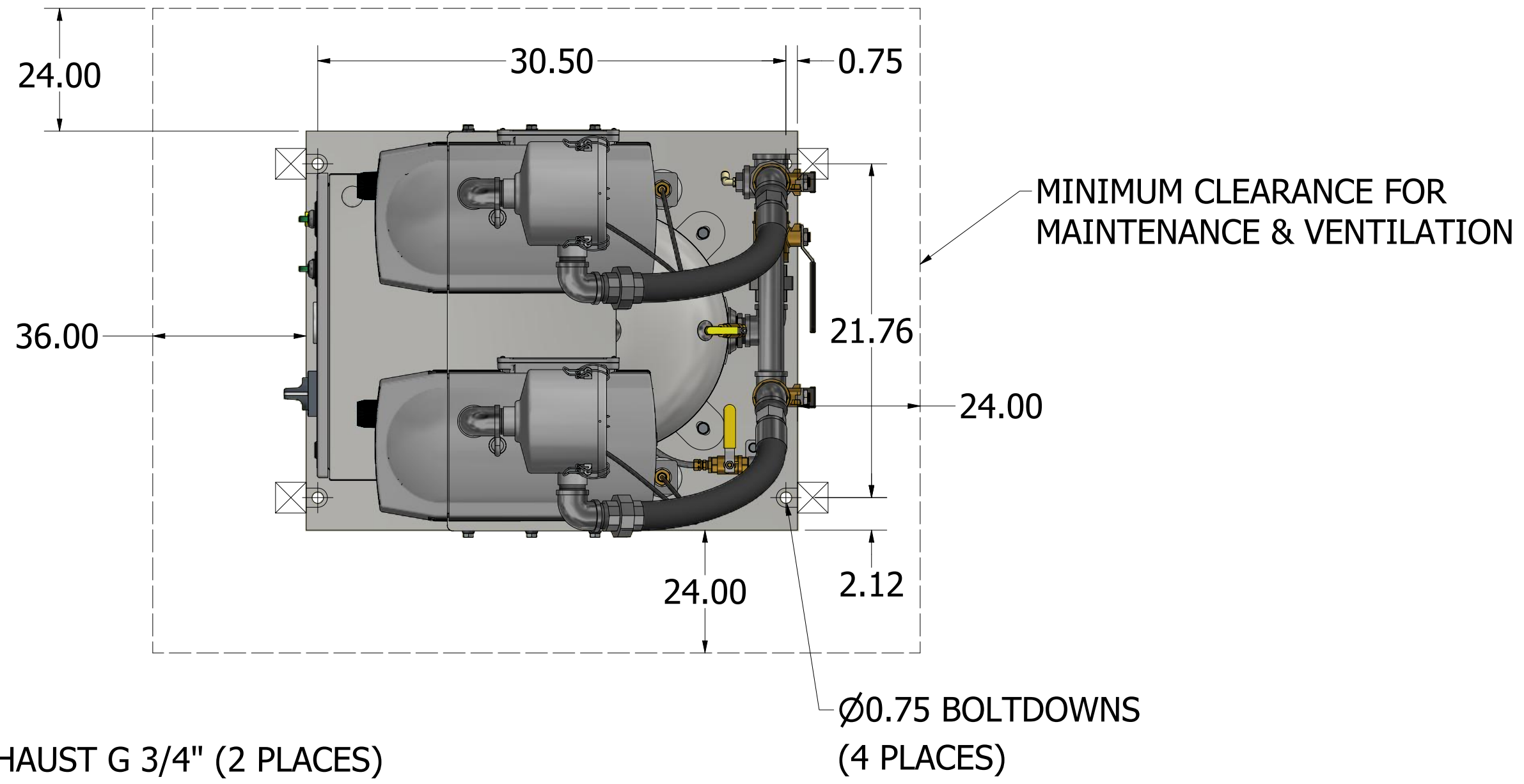

This drawing and the information contained thereon remain the property of BeaconMedaes and may not be used for other than the purpose for which it is loaned without the expressed written permission from BeaconMedaes Engineering.

**Notes:**

1. SYSTEM WEIGHT: 503 LBS
2.  INDICATES LIFTING POINTS
3.  DENOTES CENTER OF GRAVITY

| SYSTEM CONNECTIONS |                    |
|--------------------|--------------------|
| ID                 | DESCRIPTION        |
| I                  | INLET LOCATION     |
| D                  | DISCHARGE LOCATION |
| T                  | TANK DRAIN         |



|                                                                                       |       |                                                                                                                                                                                                                                      |                 |
|---------------------------------------------------------------------------------------|-------|--------------------------------------------------------------------------------------------------------------------------------------------------------------------------------------------------------------------------------------|-----------------|
| Revised:                                                                              | Date: | Drawn: BKW                                                                                                                                                                                                                           | Date: 7/27/2022 |
|  |       | This drawing and the information contained thereon remain the property of BeaconMedaes and may not be used for other than the purpose for which it is loaned without the expressed written permission from BeaconMedaes Engineering. |                 |
| Description: DWG GA DX 1.2HP DRY VTM V 30G BASIC BECKER                               |       | Part Number: 4107 8579 74                                                                                                                                                                                                            |                 |
| Sheet 1 of 1                                                                          |       | Rev: 00<br>DO NOT SCALE THIS DOCUMENT                                                                                                                                                                                                |                 |