

Notes:

1. MAIN DISCONNECT PROVIDED BY OTHER.
2. FIELD WIRING TO BE COPPER RATED FOR 75°C MINIMUM.
3. - - - - INDICATES FIELD WIRING OUTSIDE OF CABINET.
4. AUXILIARY CONTACTS ON PCB-12 ARE "CLASS 1 CONTROL CIRCUITS. USE CLASS 1 CONDUCTORS."
5. AUXILIARY CONTACTS ARE RATED 0.7 Adc/0.7Arms @ 24V MAX. UNLESS OTHERWISE NOTED.
6. AUXILIARY CONTACTS CLOSED DURING NORMAL OPERATION.
7. THE AMPACITY OF CONDUCTORS SUPPLYING THE CONTROL PANEL TO BE ROUNDED UP TO THE NEXT SIZE LARGER STANDARD WIRE GAUGE.
8. MOP VALUES TO BE ROUNDED DOWN TO THE NEAREST STANDARD RATING OF THE OVERCURRENT PROTECTION DEVICE.
9. SHORT CIRCUIT CURRENT RATING (SCCR): 65 kA

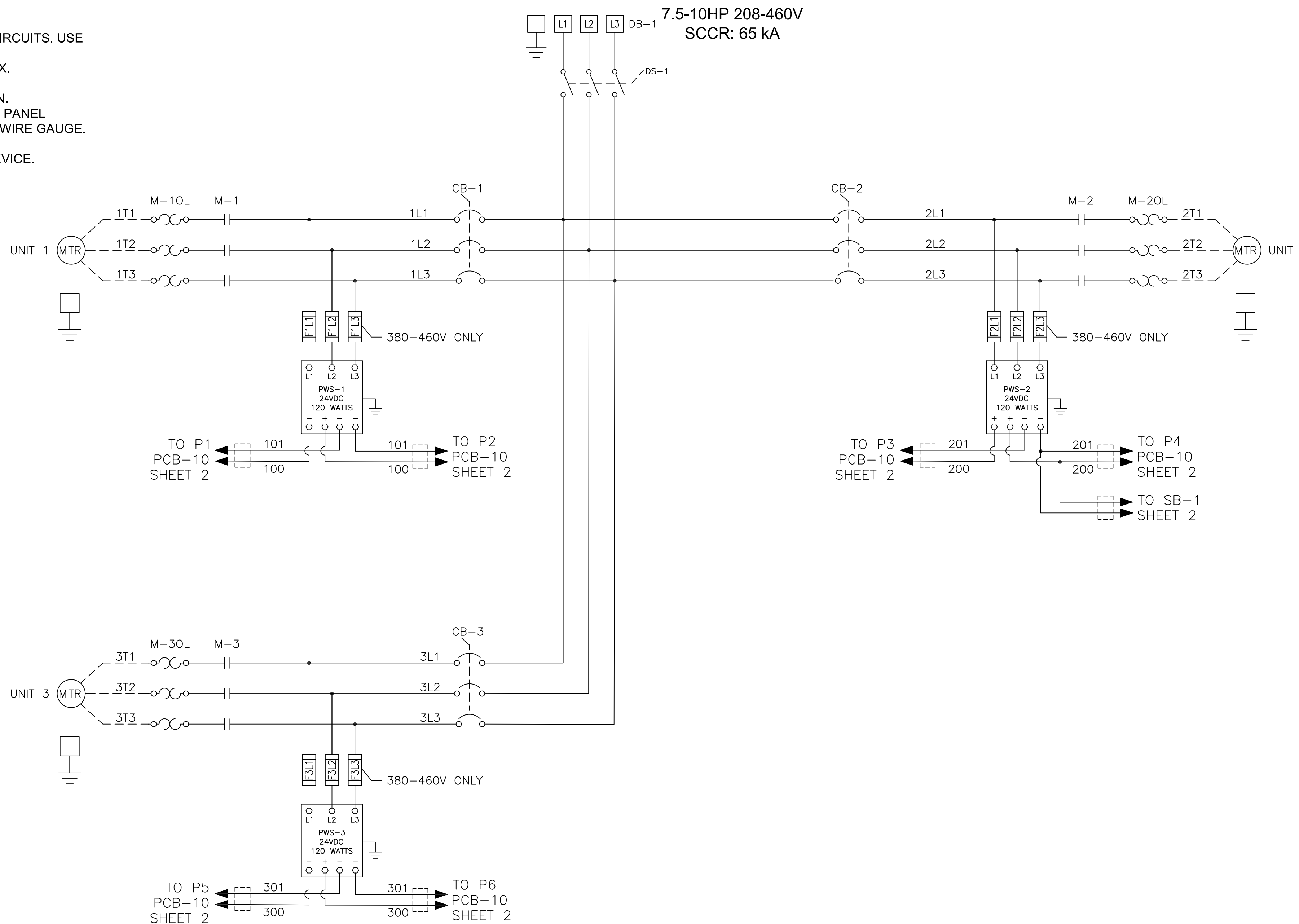

MINIMUM CIRCUIT AMPACITY (MCA)

SYSTEM HP	208 V	230 V	460 V
7.5 HP	81.3 AMPS	73.9 AMPS	37.3 AMPS
10 HP	102.7 AMPS	93.4 AMPS	47.0 AMPS

MAXIMUM OVERCURRENT PROTECTION (MOP)

SYSTEM HP	208 V	230 V	460 V
7.5 HP	102.9 AMPS	93.5 AMPS	46.8 AMPS
10 HP	130.9 AMPS	119.0 AMPS	59.5 AMPS

TRIPLEX SYSTEM FULL LOAD AMPERES

SYSTEM HP	208 V	230 V	460 V
7.5 HP	65.1 AMPS	60.7 AMPS	30.6 AMPS
10 HP	87.6 AMPS	79.3 AMPS	39.9 AMPS

INDIVIDUAL FULL LOAD AMPERES

SYSTEM HP	208 V	230 V	460 V
7.5 HP	21.0 AMPS	19.6 AMPS	9.8 AMPS
10 HP	28.5 AMPS	25.8 AMPS	12.9 AMPS

FUSE SELECTION CHART (MAX FUSE SIZES SHOWN)

SYSTEM HP	FUSES	208 V	230 V	460 V
ALL	F1L1-F3L1 F1L2-F3L2	6.0 AMPS	6.0 AMPS	6.0 AMPS
	F1L3-F3L3	---	---	6.0 AMPS
	F1/F2/F3/F4 F5/F6	4.0 AMPS	4.0 AMPS	4.0 AMPS
	F7/F8/F9/F10 F11/F12/F13	1.0 AMP	1.0 AMP	1.0 AMP
	F14	3.0 AMP	3.0 AMP	3.0 AMP

F1L1-F3L1/F1L2-F3L2/F1L3-F3L3 ARE LITTLEFUSE KLDR 600V TYPE  
F1-F13 ARE SCHURTER UMT 250 TIME-LAG 250 VAC TYPE  
F14 IS LITELFUSE 2AG 250V TYPE

RELIEF VALVE SETTINGS ("HgV)

ALTITUDE	7.5HP	10HP
0-1000'	21.5	23
1001-2000'	20.5	22
2001-3000'	19.5	21
3001-4000'	18.5	20
>4000'	CONSULT FACTORY	

DEFAULT VACUUM SETTINGS ("Hg)

ALTITUDE	LEAD CUT-OFF	LAG CUT-ON	MAXIMUM LIMITS	MINIMUM LIMITS
0-1000'	21	16	25 18	21 16
1001-2000'	20	16	24 18	21 16
2001-3000'	19	16	23 18	21 16
3001-4000'	18	16	22 18	21 16
>4,000'	CONSULT FACTORY			

AUTO OPERATION:

DURING NORMAL OPERATION, THE SYSTEM PCB WILL SIGNAL THE LEAD VACUUM PUMP TO START WHEN THE VACUUM FALLS BELOW THE SET-POINT. IF ONE PUMP CAN CARRY THE LOAD, THEN THE VACUUM WILL RISE TO THE SET-POINT. THE PUMP PCB WILL THEN TURN OFF THE LEAD VACUUM PUMP WHEN ITS RUN TIMER EXPIRES. WHEN THE SYSTEM VACUUM FALLS AGAIN, THE SYSTEM PCB WILL SEQUENCE THE LEAD ROLE TO THE NEXT PUMP PCB AND IT WILL START. IF DURING OPERATION THE SYSTEM VACUUM FALLS BELOW 15"Hg, THE LAG PUMP WILL START AND A LAG ALARM WILL OCCUR.

PUMP PCB S1 POSITION:

POSITION (A) - AUTO (DEFAULT):

THE PUMP WILL OPERATE NORMALLY AS DESCRIBED ABOVE IN "AUTO OPERATION".

POSITION (X) - OFF:

THE PUMP IS DISABLED FROM RUNNING.

POSITION (O) - MANUAL:

THE PUMP WILL RUN CONTINUOUSLY.

PCB FAULT:

IF A PUMP PCB FAULT OR A TRANSDUCER FAULT OCCURS, THE PUMP PCB WILL AUTOMATICALLY SWITCH TO MANUAL MODE. COMPRESSORS WILL START WHEN BVS-1 (BACKUP VACUUM SWITCH) CLOSSES AND STOP WHEN IT OPENS AND THE RUN TIMER EXPIRES.

SYSTEM/PUMP PCB JUMPER/SWT SETTINGS

JPR/SWT	POSITION
JP1	1-2 (SYSTEM ONLY)
S1	A (AUTO)

BACKUP VACUUM SWITCH ("HgV)

BVS-1	CUT-ON	15
-------	--------	----

Revised:	Date:	Drawn:	TAR	Date:	06/08/23
		This drawing and the information contained thereon remain the property of BeaconMedas and may not be used for other than the purpose for which it is loaned without the expressed written permission from BeaconMedas Engineering.			
Description: DWG WIRING CONTROL TX DRY 7.5-10HP GEN2 208-460/3/50-60, 65kA		Part Number: 4107 8581 30		Scale: NTS	
DN: HOP230821		Rev: 00		Sheet 1 of 4	

Notes:

1. FIELD WIRING TO BE COPPER RATED FOR 75°C MINIMUM.

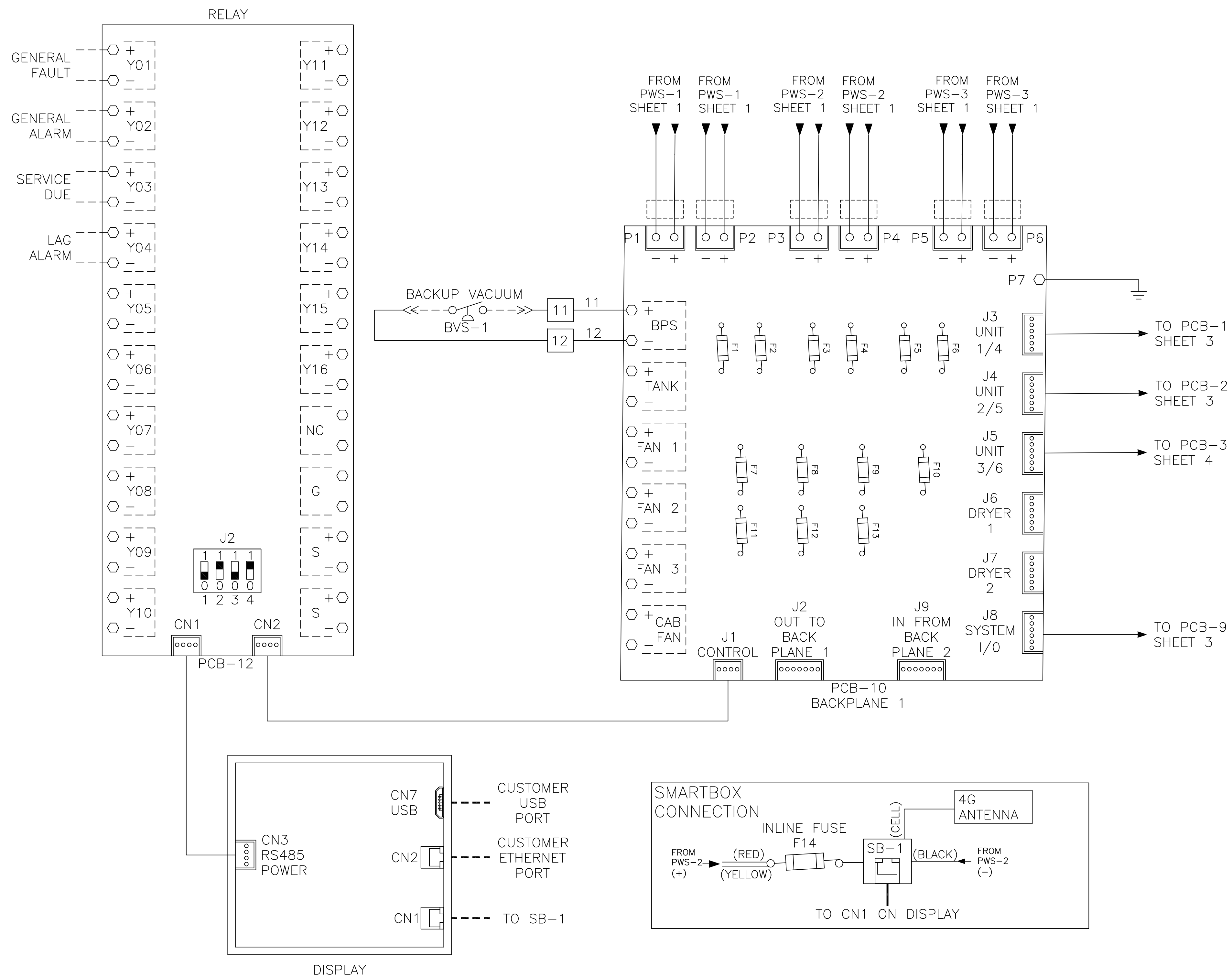

Revised:	Date:	Drawn: TAR	Date: 06/08/23
		<small>This drawing and the information contained herein remain the property of BeaconMedes and may not be used for other than the purpose for which it is loaned without the expressed written permission from BeaconMedes Engineering.</small>	
Description:		Part Number:	Scale: NTS
DWG WIRING CONTROL TX DRY 7.5-10HP GEN2 208-460/3/50-60, 65kA		4107 8581 30	<b>D</b>
DN:	HOP230821	Rev:	00
Sheet 2 of 4	DO NOT SCALE THIS DOCUMENT		1

Notes:

1. FIELD WIRING TO BE COPPER RATED FOR 75°C MINIMUM.

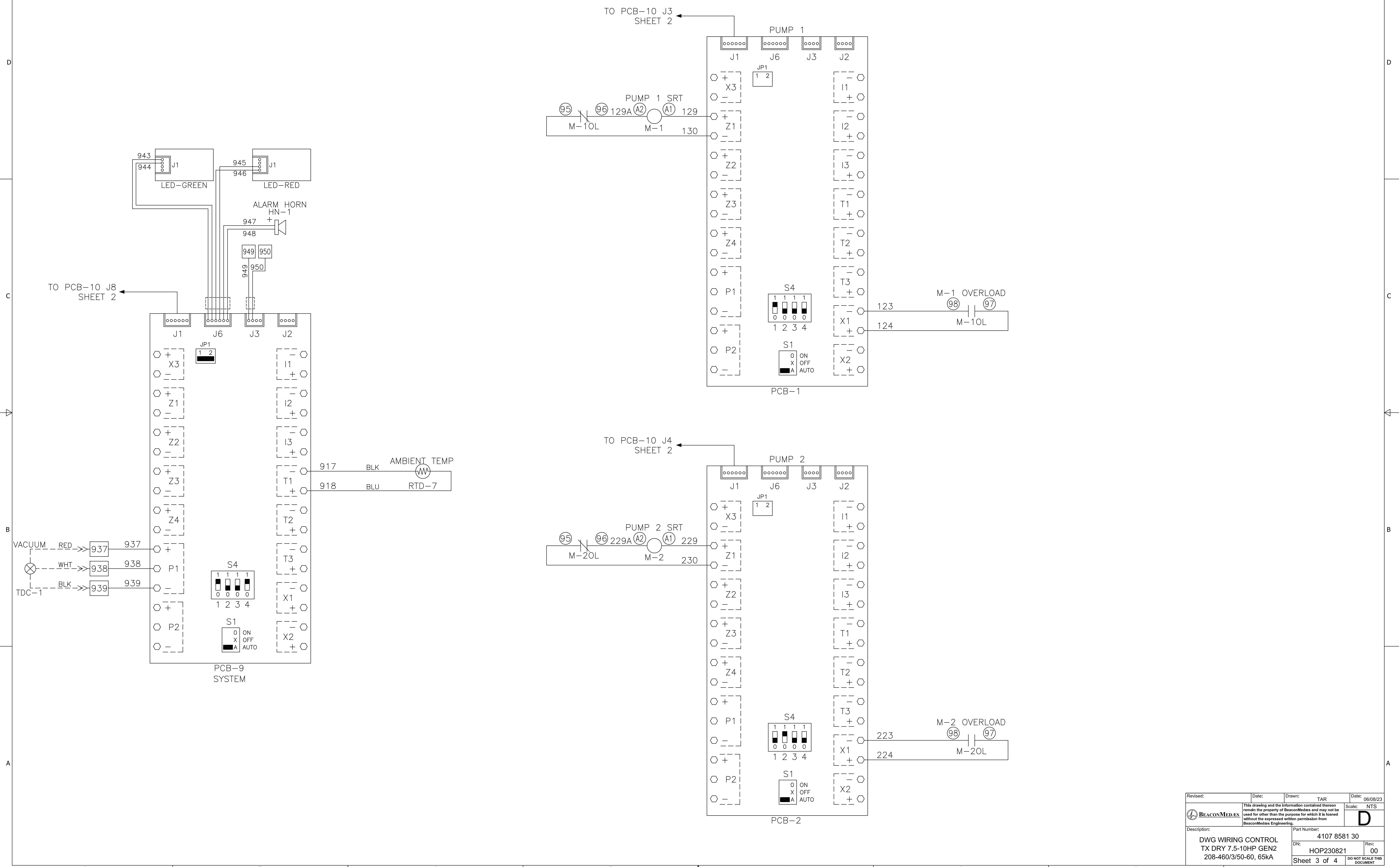

Revised:	Date:	Drawn:	TAR	Date:	06/08/23
		This drawing and the information contained thereon remain the property of BeaconMedes and may not be used for other than the purpose for which it is loaned without the expressed written permission from BeaconMedes Engineering.			
Description: DWG WIRING CONTROL TX DRY 7.5-10HP GEN2 208-460/3/50-60, 65kA		Part Number: 4107 8581 30			
DN: HOP230821		Rev: 00		Scale: NTS	
Sheet 3 of 4		DO NOT SCALE THIS DOCUMENT			

Notes:

1. FIELD WIRING TO BE COPPER RATED FOR 75°C MINIMUM.

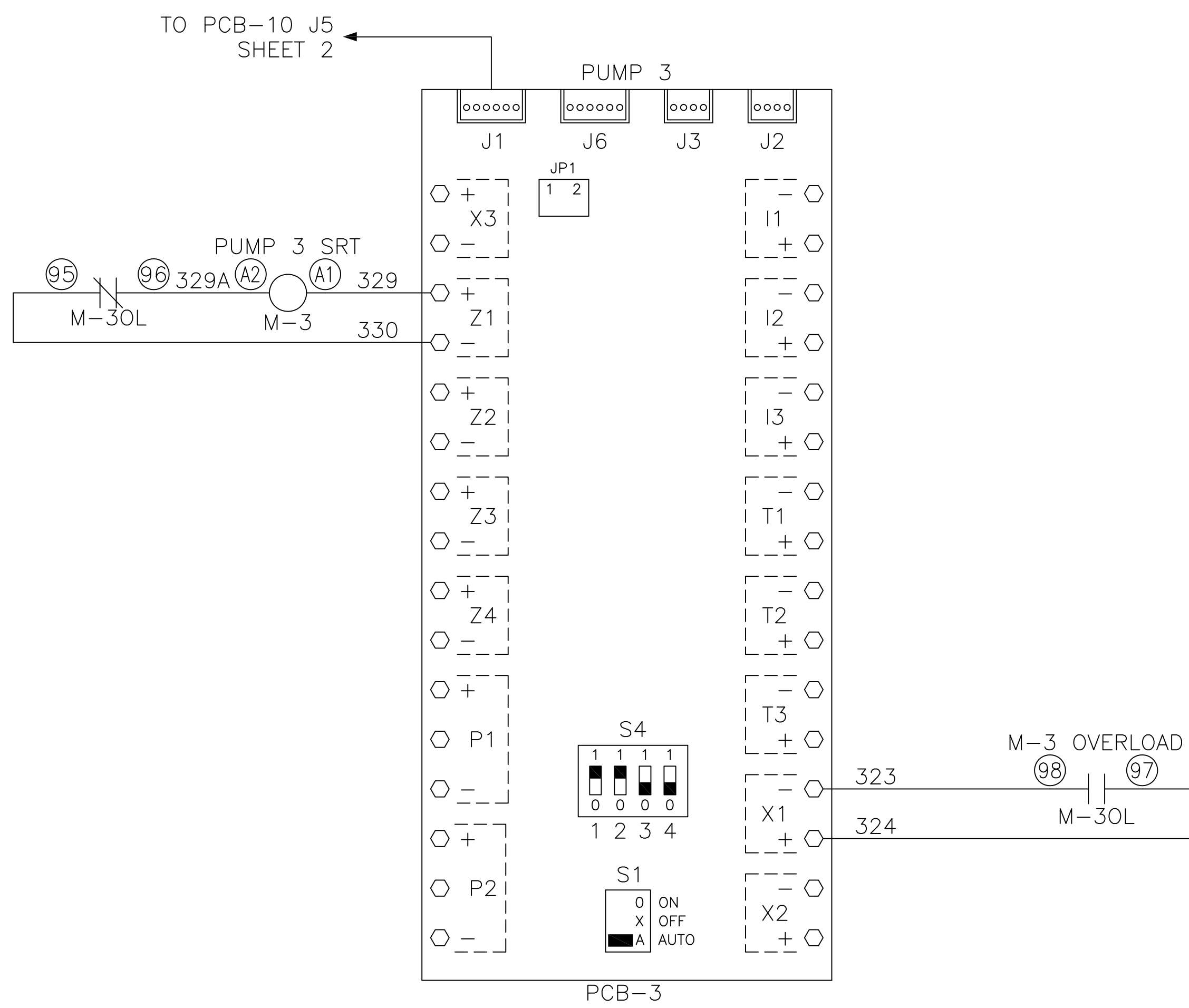

Revised:	Date:	Drawn:	TAR	Date:	06/08/23
<small>This drawing and the information contained thereon remain the property of BeaconMedas and may not be used for other than the purpose for which it is loaned without the expressed written permission from BeaconMedas Engineering.</small>		<small>Scale:</small> NTS		<small>Rev:</small> 00	
<b>BEACONMEDAS</b>		<b>D</b>		<b>00</b>	
Description: DWG WIRING CONTROL TX DRY 7.5-10HP GEN2 208-460/3/50-60, 65kA		Part Number: 4107 8581 30		Rev: 00	
DN: HOP230821		Sheet 4 of 4		DO NOT SCALE THIS DOCUMENT	