

BeaconMedaes

Medical Vacuum Supply System - mVAC



Instruction book



BeaconMedaes

Medical Vacuum Supply System - mVAC

Instruction book

Original instructions

Copyright notice

Any unauthorized use or copying of the contents or any part thereof is prohibited.

This applies in particular to trademarks, model denominations, part numbers and drawings.

This instruction book is valid for CE as well as non-CE labelled machines. It meets the requirements for instructions specified by the applicable European directives as identified in the Declaration of Conformity.



Issue Record

Document No.	Revision No.	Detail of changes	Effective Date
4233500234	03	IAR 10801: Audit findings update	08-Sep-2025

Table of contents

1	Safety precautions	6
1.1	SAFETY PRECAUTIONS, GENERAL.....	6
1.2	SAFETY PRECAUTIONS DURING INSTALLATION.....	6
1.3	SAFETY PRECAUTIONS DURING OPERATION.....	7
1.4	SAFETY PRECAUTIONS DURING MAINTENANCE OR REPAIR.....	7
2	General information	9
2.1	DEVICE DESCRIPTION.....	9
2.2	ISO/HTM STATEMENT.....	11
2.3	WARNING.....	11
2.4	CAUTION.....	12
2.5	DEVICE LIMITATION.....	12
2.6	ANTICIPATED LIFETIME.....	12
2.7	DESCRIPTION OF SYMBOL.....	12
3	General description	14
3.1	VACUUM AND FLOW RATE.....	14
3.2	INTRODUCTION.....	15
3.3	PLANT DESCRIPTION.....	18
3.4	VACUUM VESSEL(S).....	19
3.5	VACUUM PUMPS.....	20
3.6	BACTERIAL VACUUM FILTERS.....	21
3.7	PRESSURE SENSORS.....	22
3.8	PUMP CONTROL UNITS.....	22
3.9	CENTRAL CONTROL UNIT.....	23
4	Installation	24
4.1	INTRODUCTION.....	24

4.2	INSTALLATION NOTES	24
4.3	MECHANICAL INSTALLATION	26
4.4	STORAGE.....	31
4.5	ELECTRICAL CONNECTIONS	31
5	Commissioning.....	32
5.1	INTRODUCTION	32
5.2	PRE-START INSPECTION.....	32
5.3	ELECTRICAL FUNCTIONAL CHECK.....	33
5.4	SETTING THE PNEUMATIC SYSTEM.....	33
5.5	AUTOMATIC OPERATION AND LEAK CHECK.....	33
5.6	STARTING THE PLANT	34
6	Operation user guide.....	35
6.1	INTRODUCTION	35
6.2	PUMP CONTROLLER.....	35
6.3	CENTRAL CONTROLLER (ES-VAC)	47
6.4	CONTROLLER ALARMS AND FAULTS	69
7	Maintenance.....	75
7.1	INTRODUCTION	75
7.2	MAINTENANCE NOTES.....	75
7.3	CHECKS AND INTERVALS.....	77
7.4	OIL, OIL FILTER AND OIL SEPARATOR CHANGE	80
7.5	OIL SPECIFICATIONS.....	81
7.6	BACTERIAL FILTER REPLACEMENT	82
7.7	DRAIN FLASK CHANGE	83
7.8	NON-RETURN VALVE AND INLET SCREEN REPLACEMENT	83
7.9	CHANGE FROM MINERAL OIL TO SYNTHETIC OIL.....	84
7.10	VACUUM PUMP REPLACEMENT	85

7.11	DISMANTLING AND DISPOSAL	85
7.12	SERVICE KITS	86
8	Pictographs	87
9	Problem solving	88
9.1	INTRODUCTION AND WARNINGS	88
9.2	FAULTS AND REMEDIES	88
10	Technical data	99
10.1	ELECTRIC CABLE SIZE	99
10.2	FUSE VALUES	100
10.3	REFERENCE CONDITIONS AND LIMITATIONS	101
10.4	PERFORMANCE DATA	101
10.5	DESIGN DATA	103
11	Usability	104
12	Reporting Serious Incidents	107
13	Online access	107
14	appendix	108
14.1	DECLARATION OF CONTAMINATION STATUS	108

1 Safety precautions

1.1 Safety precautions, general

General precautions



If the “Medical Vacuum Supply System” is received with damaged packaging the product may be compromised. Before putting into use check for any visible signs of damage to the product, with special attention to components that will be in contact with the medical gas with regard to ruptures or compromised cleanliness. Contact [BeaconMeades] for guidance regarding repair or replacement if needed.



All responsibility for any damage or injury resulting from neglecting these precautions, or non-observance of the normal caution and care required for installation, operation, maintenance, and repair, even if not expressly stated, will be disclaimed by the manufacturer.

1. The operator must employ safe working practices and observe all related work safety requirements and regulations.
2. If any of the following statements does not comply with the applicable legislation, the stricter of the two shall apply.
3. Installation, operation, maintenance and repair work must only be performed by authorized, trained, specialized personnel.

1.2 Safety precautions during installation

Precautions during installation

1. Place the device where the ambient air is as cool and clean as possible, within the limitations for operation (see section Reference conditions and Limitations).
2. During installation or any other intervention on one of the connected pumps or cubicles, the pump must be stopped, de-energized and the isolating switch opened and locked before any maintenance or repair. As a further safeguard, persons switching on remotely controlled machines shall take adequate precautions to ensure that there is no one checking or working on the machine. To this end, a suitable notice shall be affixed to the start equipment.
3. The electrical connections must correspond to the local codes. The device must be earthed and protected against short circuits by fuses in all phases. A lockable power isolating switch must be installed near the device.
4. Never remove or tamper with the safety devices.



Also consult following safety precautions: [Safety precautions during operation](#) and [Safety precautions during maintenance or repair](#).

These precautions apply to the mVAC plant.

For precautions applying to the connected equipment consult the relevant instruction book. Some precautions are general and cover several machine types and equipment; hence some statements may not apply to your device.

1.3 Safety precautions during operation

Precautions during operation

1. Persons switching on remotely controlled machines shall take adequate precautions to ensure that there is no one checking or working on the machine. To this end, a suitable notice shall be affixed to the remote start equipment.
2. Never operate the device in the presence of flammable or toxic fumes, vapours or particles.
3. Never operate the machine below or in excess of its limit ratings.
4. Wear ear protectors if applicable. People staying in environments or rooms where the sound pressure level reaches or exceeds the local specified dB(A) limit value shall wear ear protectors.
5. Periodically check that:
 - All guards and fasteners are in place and tight
 - All hoses and/or pipes are in good condition, secure and not rubbing
 - There are no leaks
 - All electrical leads are secure and in good order
6. Never remove or tamper with the safety devices.



Also consult following safety precautions: [Safety precautions during installation](#) and [Safety precautions during maintenance or repair](#).

These precautions apply to the mVAC plant.

For precautions applying to the connected equipment consult the relevant instruction book. Some precautions are general and cover several machine types and equipment; hence some statements may not apply to your device.

1.4 Safety precautions during maintenance or repair

Precautions during maintenance or repair

1. Use only the correct tools for maintenance and repair work.
2. Use only genuine spare parts.
3. A warning sign bearing a legend such as <<Work in progress - do not start>> shall be attached to the starting equipment, including all remote start equipment.
4. Persons switching on remotely controlled machines shall take adequate precautions to ensure that there is no one checking or working on the machine. To this end, a suitable notice shall be affixed to the remote start equipment.
5. Never use flammable solvents or carbon tetrachloride for cleaning parts. Take safety precautions against toxic vapours of cleaning liquids.
6. Scrupulously observe cleanliness during maintenance and repair. Keep dirt away by

cleaning the parts and exposed openings with a clean cloth, paper or tape.

7. Never use a light source with open flame for inspecting the interior of the device.
8. All regulating and safety devices shall be maintained with due care to ensure that they function properly. They may not be put out of action.
9. Before clearing the device for use after maintenance or repair, check that operating pressures, temperatures and time settings are correct. Check that all control and shutdown devices are fitted and that they function correctly.



Also consult following safety precautions: [Safety precautions during installation](#) and [Safety precautions during operation](#).

These precautions apply to the mVAC plant.

For precautions applying to the connected equipment consult the relevant instruction book. Some precautions are general and cover several machine types and equipment; hence some statements may not apply to your device.



Units and/or used parts should be disposed of in an environmentally friendly and safe manner and in line with the local recommendations and legislation.

2 General information

2.1 Device Description

The device shall operate in a manner that complies to both HTM 02-01 and ISO 7396-1 requirements.

This device is defined within ISO 7396-1 as one or more source of supply which assists with maintaining continuity of supply to the medical vacuum pipeline.

Intended Use of the Device

The device is intended to work in conjunction with other devices within the medical gas pipeline system (MGPS) to assist with maintaining continuity of medical vacuum supply throughout the hospital to local connection points for eventual removal of fluids from the human body.

The device controls the vacuum pressure within the specification as required by the MGPS. In all cases other devices outside of this scope are connected downstream of the MGPS are required to control the final vacuum pressure and flow requirements for safe supply from the patient. Therefore, this device is not intended to control supply parameter hazards directly to the patient, only to the MGPS.

Intended Patient Population

The device is intended to be used in conjunction with other medical vacuum pipeline equipment in hospitals and have no direct contact with patients. Medical Vacuum Pipeline Systems supply vacuum to medical equipment which can be used across any populations & all age groups.

Intended Use Profile

Medical Vacuum Supply System is intended for use by appropriately qualified and trained personnel only who have undergone relevant 'HTM 02-01 Authorised Person' (AP) training regarding the safe use of medical gas supply systems.

The device should only be installed, commissioned, operated, and maintained by technicians who are suitably trained with medical gas systems, such as Competent or Authorised Persons as defined in UK Department of Health Technical Memorandum No. 02-01 (HTM 02-01 Part B: Operational Management). The device is intended for use by appropriately qualified technical personnel only. This condition is emphasised in the IFUs.

Reference: HTM 02-01 Medical gas pipeline systems – Part B: Operational Management.

Authorised Person (MGPS)

4.21 The Authorised Person (MGPS) is defined as that person designated by the Executive Manager to be responsible for the day-to-day management of the MGPS at a particular site or sites. This includes the issue of permits in accordance with the permit-to-work procedure. The principal responsibilities of the Authorised Person (MGPS) in respect of the permit-to-

work procedure are set out in paragraph 6.91. The Authorised Person (MGPS) also has specific duties with regard to VIE installations (see Appendix E).

Competent Person (MGPS)

4.40 The Competent Person (MGPS) is the person who carries out the installation and/or maintenance work on the MGPS. A list of his/her responsibilities and duties is set out in paragraph 6.92. The Competent Person (MGPS) should have received appropriate training and should be on a list of Competent Persons (MGPS). In the case of directly employed labour, this list should be held by the Authorised Person (MGPS); in the case of contracted labour, it should be held by the contractor's Authorised Person (MGPS) or project manager.

Indications

Medical Vacuum Supply System is used as part of medical vacuum pipeline systems where an uninterrupted supply of medical vacuum is required. The medical device works in conjunction with other medical devices for the immediate and reliable delivery of medical vacuum to terminal units used for removal of body liquids in healthcare facilities. In all cases there are medical devices installed between this device and the patient that controls the flow and vacuum to safe levels to the patient. This device therefore only delivers medical vacuum within specification to the medical gas pipeline system, not directly to the patient.

Contraindications

If the device sustains any damage or malfunctioning, the assembly or faulty part should be replaced completely. This ensures all damaged components are replaced.

Contraindications for use, warnings and precautions related to the safe use of the devices are detailed in the IFU supplied with the devices. These sections shall be read by the intended user before installing the device and starting to use it.

Environmental Transport and Storage Conditions

All products are separately packaged and stored in controlled conditions.

Minimum storage temperature: 0°C

Maximum storage temperature: +40°C

Environmental Operating Conditions

Adverse environmental conditions and harsh abrasives or chemicals may cause damage to the unit.

Minimum working temperature: +5°C

Maximum working temperature: +40°C

2.2 ISO/HTM Statement

The source of supply is defined differently for HTM02-01, HTM2022 and ISO medical vacuum systems. When used as a main supply manifold, the source of supply is defined as below:

Standard	Primary Source	Secondary source	Reserve source
HTM02-01	Duty pump/s system	2 x Standby pump system	Portable suction equipment
HTM2022	Duty compressor/s	1 x standby compressors	Portable suction equipment
ISO	Duty pump/s system	1st standby pump system	2nd standby pump system Maybe automatic or manual start.

2.3 Warning

1. Read through these entire instructions before using or showing others how to use this equipment. As with all medical equipment, attempting to use this device without a thorough understanding of its operation may result in patient or user injury
2. Electrical system should only be worked on by a competently trained electrician who is familiar with local wiring regulations. Verify zero voltage using appropriate testing equipment before commencing work on the electrical system.
Isolation process:
 - a Switch off the isolator.
 - b Apply lock-off devices and warning tags.
 - c Verify zero voltage using appropriate testing equipment.Only after confirming safe isolation, maintenance may begin
3. Do not attempt to modify this device in any way not strictly described within this manual.
4. Obtain a work permit before commencing any work on a medical gas installation.
5. No attempt should be made to use this product with a gas service or at a pressure other than as identified.
6. Do not use this product if it appears damaged in any way.
7. This equipment should only be installed, commissioned, operated and maintained by technicians who are suitably trained with medical gas systems, such as Competent or Authorised Persons as defined in UK Department of Health Technical Memorandum No. 02-01 (HTM 02-01).
8. Vacuum system components should be treated as a bio-hazard and handled and decontaminated accordingly if microbially contaminated
9. Vacuum pump surfaces may be hot and should not be touched
10. Isolate to the pipeline during brazing of the connection line.
11. Check the gas pipeline labelling matches the device before connecting to the pipeline
12. Portable and mobile RF communications equipment can affect the mVAC. They should be used no closer to any part of the mVAC, including cables, than the recommended separation distance calculated from the equation applicable to the frequency of the transmitter (See EN 60601)
13. The mVAC is intended for use in the electromagnetic environment specified below. The customer or user should assure that it is used in such an environment.
14. Filter elements cannot be cleaned or reused. Dispose of in accordance with hospital procedures for contaminated waste

2.4 Caution

1. Use of sub-standard or inappropriate parts and materials may damage the product and invalidate the warranty. Only use genuine BeaconMedaes spare parts.
2. Leak detection fluids contain surface active agents (surfactants) that can damage plastic components under stress. Only use leak detection fluids that are compatible with the materials being tested.
3. Do not mix oil and fully clean any remaining oil during service.
4. Always wash leak detection fluids off with clean water immediately after use.













2.5 Device Limitation



















This medical vacuum system is intended solely for clinical suction use in fixed indoor healthcare installations compliant with HTM 02-01 and ISO 7396-1. It must only be used for medical vacuum (negative pressure) applications and not with flammable, toxic, or pressurized gases. Only authorized personnel may install or service the system. Unauthorized modifications, non-approved accessories, or use outside validated environmental and electrical conditions are not permitted. This system is not a substitute for emergency portable suction devices.

2.6 Anticipated lifetime

The anticipated lifetime of the vacuum system is 10 years from the date of installation, assuming proper maintenance, service and environmental conditions are met. This estimate is based on product design, historical performance, and internal technical assessments.

2.7 Description of Symbols

Symbols	Title	Symbols	Title
	Manufacturer		Protect from heat and radioactive sources
	Date of manufacture		Keep dry
	Authorized representative in the European Union		Temperature limit
	Batch code		Humidity limitation
	Catalogue Number		Atmospheric pressure limitation
	Serial number		Caution

	Unique Device Identifier		Upper limit of temperature
	Do not use if package is damaged and consult instructions for use		Biological risks
	Keep away from sunlight		Consult instructions for use or consult electronic instructions for use
	Lower limit of temperature		Medical device
	Do not dispose of in general waste	WARNING	Indicates potentially hazardous situations which, if not avoided, could result in personal injury to users or others.
CAUTION	Indicates potentially hazardous situations which, if not avoided, could result in damage to devices or personal property	NOTE	Emphasize point to achieve more convenient or efficient use of device
	WARNING! Motor Starts automatically		WARNING! surface may be hot and should not be touch
	WARNING! Dangerous voltage		WARNING! Beware of sudden loud noises
	Static sensitive components. Take appropriate precaution		Wear hand protection
	Wear ear protection		Wear eye protection
	Protective earth protection		

3 General description

3.1 Vacuum and flow rate

What is vacuum and how to denote

A vacuum is any pressure in a system that is below the ambient atmospheric pressure. It can be denoted in absolute terms or in effective (gauge) terms:

- mbar(a) - absolute pressure - denotes how much the pressure is above the absolute vacuum.
- mbar(e) - the effective or gauge pressure - denotes how much the pressure is below local atmospheric pressure.

Since an effective vacuum pressure is always referenced to absolute atmospheric pressure, effective vacuum pressures are negative values. It denotes the fixed difference between the variable atmospheric pressure (e.g. dependent on altitude and weather) and the vacuum level.

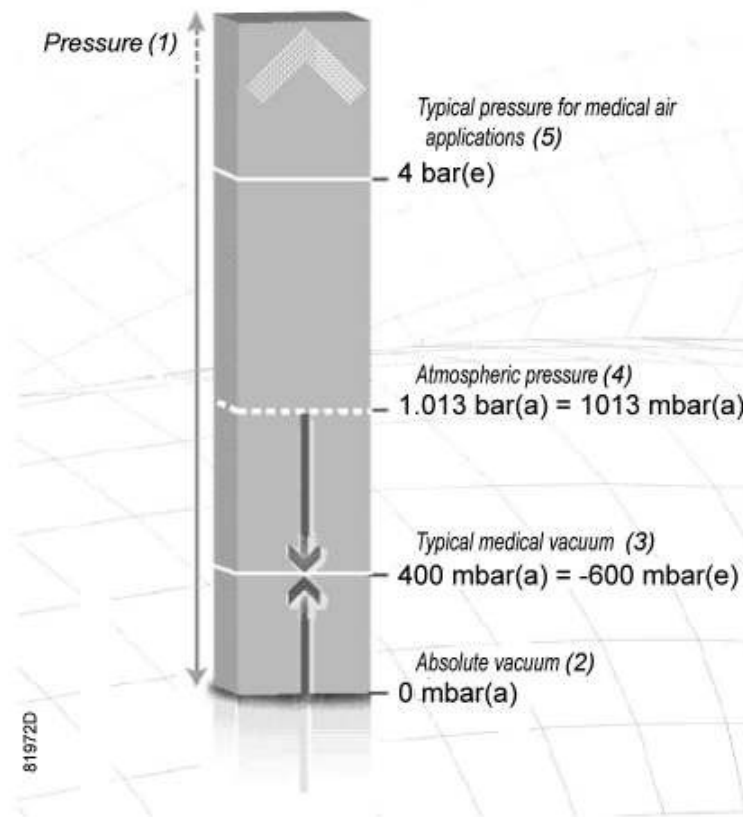

(1)	Pressure
(2)	Absolute vacuum
(3)	Typical medical vacuum
(4)	Typical atmospheric pressure (at sea level)
(5)	Typical pressure for medical air applications

Atmospheric pressure at sea level is roughly 1 bar or 1000 mbar(a). For typical medical vacuum applications, a vacuum of 600 mbar below atmospheric pressure is required, which is denoted as -600 mbar(e). From the illustration it can be seen clearly that this value is also equivalent to 400 mbar above absolute zero vacuum and can therefore also be denoted as

400 mbar(a).

It is important to understand which type of reference is required before selecting a pressure instrument for measuring the vacuum. The mVAC application uses the effective pressure system since it corresponds most with performance characteristics.

It must be noted that this distinction isn't relevant for a pressure difference (11 P, e.g. pressure loss), since it is always the result of subtracting 2 pressures (whether stated as absolute or effective pressures).

Flow rate definitions

It should be clearly understood that there is a difference between the volume of 'Free Air Aspired' (FAA) at the terminal units (atmospheric pressure) and the volume of that same quantity of air handled by the pumps at a given vacuum level. For example: 100 liters of free air aspired at atmospheric pressure corresponds to approximately 200 liters of air at a vacuum of -507 mbar(e) (-380 mmHg), and approximately 300 liters at a vacuum of -667 mbar(e) (-500 mmHg).

The volume of rarefied air flowing in a pipeline is consequently around three times the volume of the total design flow which is specified in terms of Free Air Aspired. A clear distinction should therefore be made between the FAA and the capacity (volumetric displacement) of the pumps. In order to avoid confusion, the capacity of the pumps should be given in terms of both free air and volumetric flow rate at the operating vacuum level.

Hence there are 2 common but different ways to denote flow rate in vacuum. The first one is based on the displacement or volumetric flow rate and the second one is based on the throughput or mass flow rate.

Displacement/volumetric flow rate

Over the relevant pressure range, an mVAC pump operates at quasi constant motor speed (rotations per minute) and since the compression chambers have fixed dimensions, the same volume of air is pumped from inlet to outlet with falling vacuum level. Over the relevant pressure range, this makes the volumetric flow rate quasi-independent of the vacuum level. It is the expression of the flow rate inside the piping at the governing vacuum level, and always higher than the free air aspiration flow rate.

Free Air Aspiration or FAA (based on throughput/mass flow rate)

Even if the volumetric flow rate is practically unchanged with vacuum level, the number of molecules in that pumped volume is not. By definition: the deeper the vacuum, the lower the amount of molecules in the same volume of air. This means that the mass flow will decrease with decreasing (absolute) pressure. It is clear that a flow rate must be stated at a certain vacuum level when using this denotation. For this medical vacuum application, the FAA of the plant is measured at -600 mbar(e) (-450 mmHg) and referred to free air at 1013 mbar(a) and 20 °C. Hence the FAA also expresses a volumetric flow rate which is always lower than the displacement flow rate described above.

3.2 Introduction

The Medical Vacuum Supply System is specifically designed and manufactured to fully satisfy the requirements of the European Medical Device Directive and the additional

requirements of the United Kingdom National Health Service HTM (Health Technical Memorandum) versions 2022 and 02-01. To this effect, the mVAC range consists of 2 up to 6 identical pumps which can work independently to satisfy the required vacuum flow. They keep the vacuum level at the point of connection at least as deep as -600 mbar (e) (-450 mmHg) at all times, provided the correct plant type is chosen for the hospital flow demand (see [Performance data](#)). In order to achieve this, the pumps operate between -770 and -970 mbar(e) (-578 and -728 mmHg) to account for any vacuum losses across the filters.

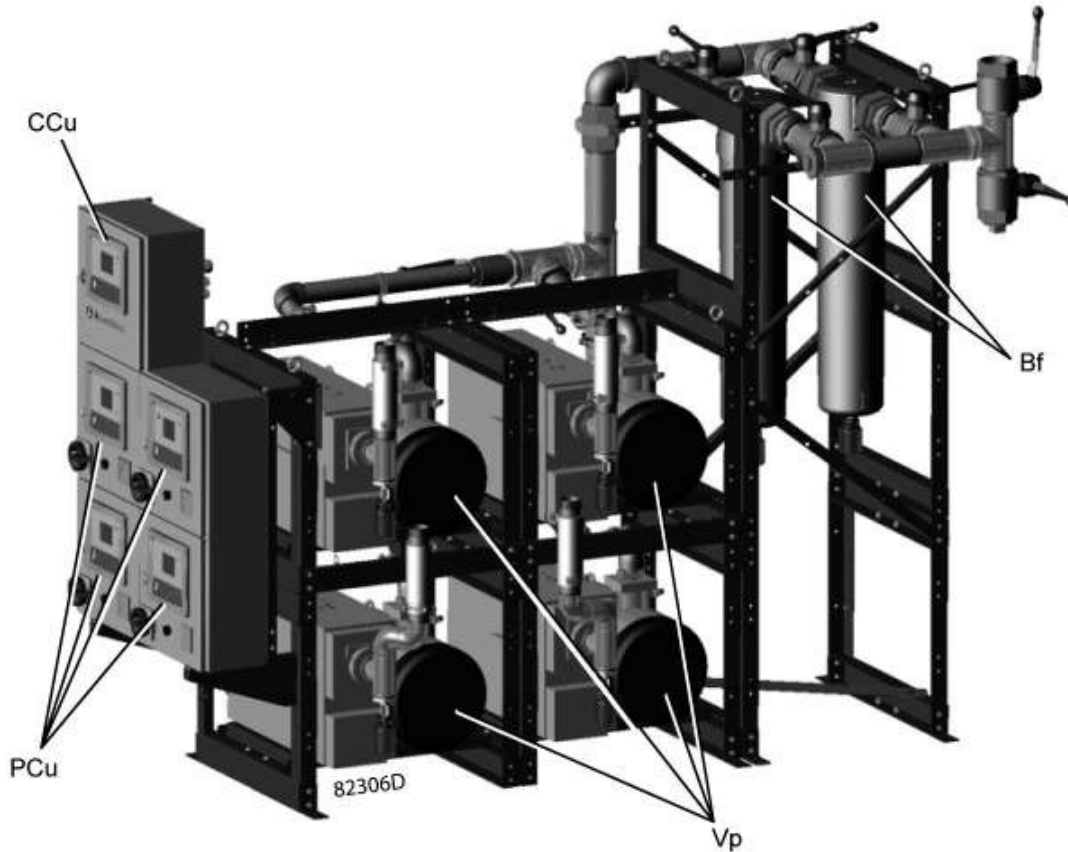

Modular stacked components

	Description		Description
Bf	Bacterial filter	PCu	Pump control unit
CCu	Central control unit	Vp	Vacuum pump

The mVAC is set up as a system with (multiple) backup supply and *control safety layers* in case of single failure of functional components. It is installed - completely piped and wired - as modular stacked components or a tank mounted unit.

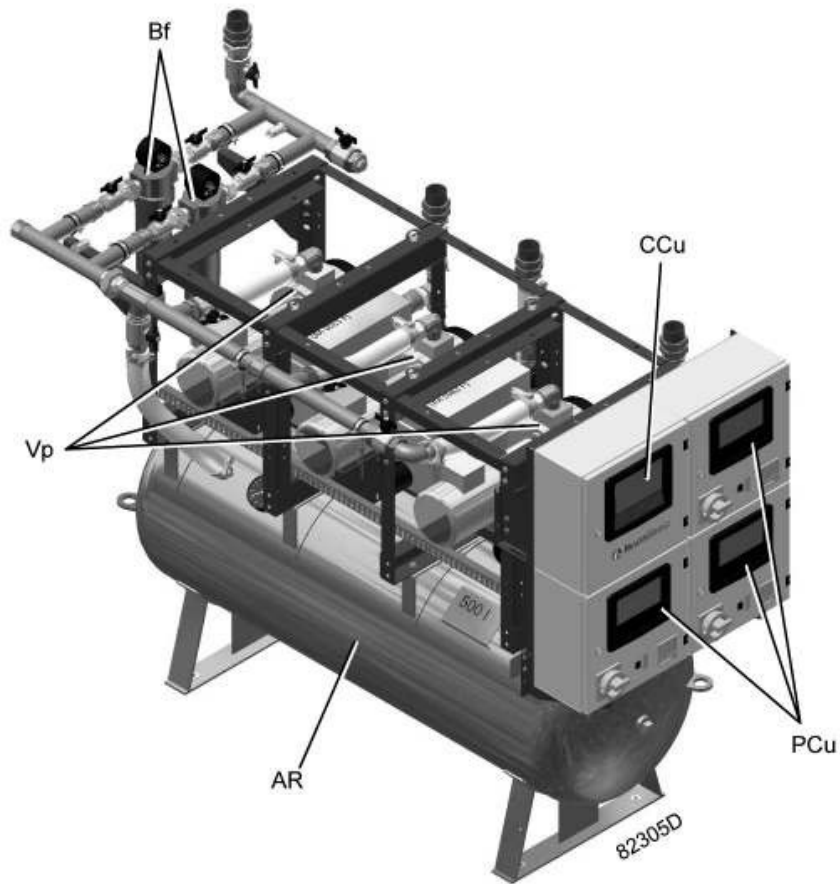

Tank mounted unit

Each plant is subject to comprehensive QA controls during manufacturing, incorporates components with proven reliability and each plant is fully tested prior to dispatch.

	Description		Description
AR	Vacuum vessel	PCu	Pump control unit
Bf	Bacterial filter	Vp	Vacuum pump
CCu	Central control unit		

3.3 Plant description

Tank mounted mVAC's are complete stand-alone assemblies with all components mounted on a single horizontal vacuum vessel. This configuration provides a compact, low footprint unit specifically designed for ease of installation. The stacked plant is supplied as principal components enabling a degree of flexibility in the installation layout.



mVAC systems complying with HTM 02-01 and ISO 7396-1 are provided with at least 2 standby pumps, e.g. the design flow of a system with 3 pumps is provided by a single pump. mVAC systems complying with HTM 2022 are provided with at least 1 standby pump, e.g. the design flow of a system with 2 pumps is provided

An mVAC consists of the following mechanical (full line) and electrical (dotted line) components, represented here on a typical setup diagram (here with 3 pumps and 2 vessels).

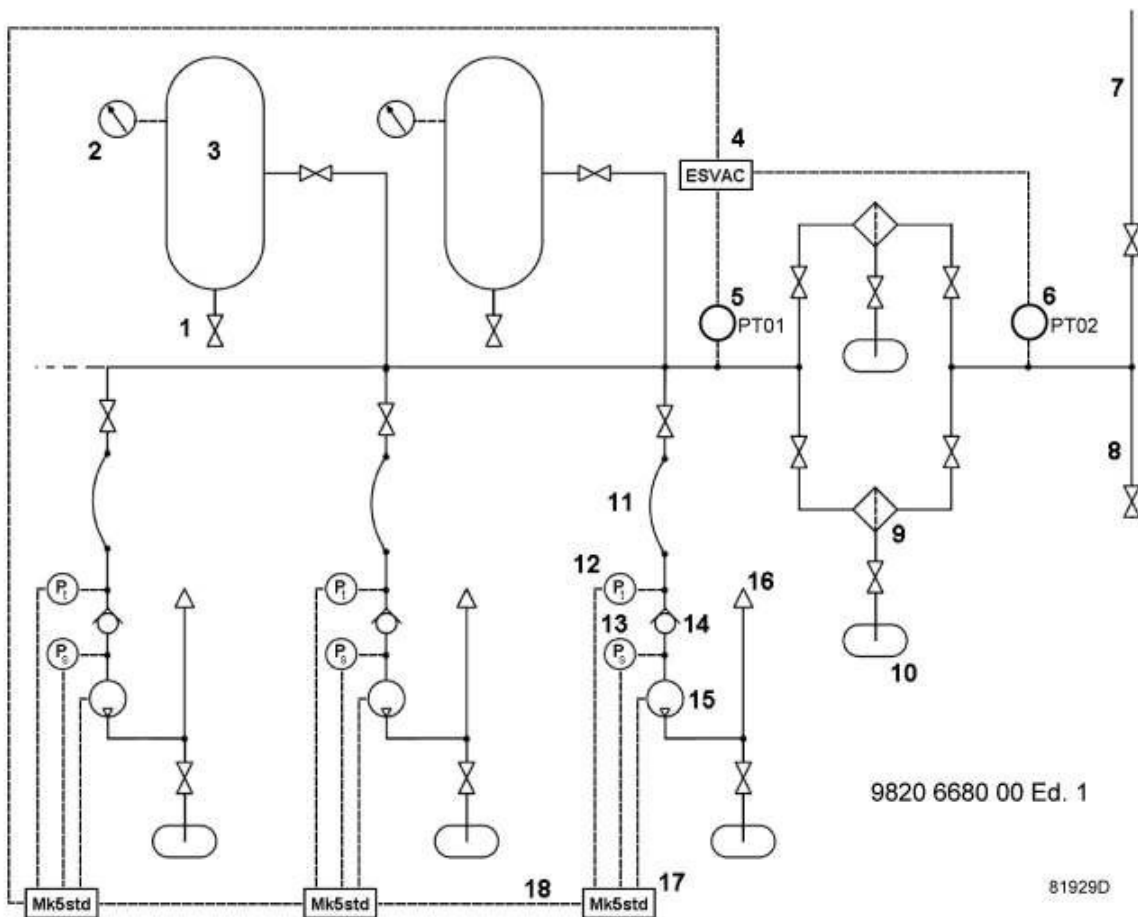

Flow diagram

Position	Component
1	Ball valve
2	Pressure gauge
3	Vacuum vessel
4	Central controller (ES-VAC)
5	Pressure transducer PT01 (downstream of filters)
6	Pressure transmitter PT02 (upstream of filters)
7	Inlet piping
8	Test connection
9	Bacterial filter (duplex configuration)
10	Drain flask
11	Flexible hose
12	Pressure transducer PT (pump inlet)
13	Pressure switch Ps (FTGOL - Failed To Go On Load)
14	Non-return valve
15	Vacuum pump
16	Exhaust
17	Pump controller
18	CAN (controller area network) connection

3.4. Vacuum vessel(s)



The vacuum reservoir ensures an instantaneous response to demand and prevents continuous operation of the 'Lead' vacuum pump during periods of light demand. It also acts as a buffer to smooth out short peaks in demand. The interior and exterior are protected against corrosion by galvanisation and access covers facilitate future insurance internal inspection. A manual drain valve is fitted to the vessel at the lowest point to enable the removal of any internal moisture which may form with condensation. There is also a tapping for a vacuum gauge. The vessel connects to the vacuum pumps and to the pipeline distribution system by external piping. The piping arrangement is valved to enable the

reservoir to be bypassed if necessary with the plant remaining operational. The tank mounted vacuum plant reservoir is mounted horizontally, the stacked plants reservoir(s) are mounted vertically. Although essentially designed as a free standing unit, the vessel feet are rough-drilled to enable the plant to be bolted down if required. With a tank mounted plant, the reservoir incorporates a mounting saddle to secure the vacuum pumps and control modules. Test details are annotated on a plate permanently fixed to the reservoir.

The reservoir capacity is expressed as the water capacity in litres and the installed capacity is at least equivalent to the design flow rate (free air aspired per minute) of the plant.

3.5 Vacuum pumps



Identical vacuum pumps are used for the mVAC range. The vacuum pumps are air cooled, oil flooded rotary vane pumps. Each pump has an integral separator filter which ensures a virtually oil-free exhaust. Each vacuum pump is capable of reducing the reservoir/pipeline pressure from atmospheric to below -999 mbar(e) (-750 mmHg) in a no flow condition. The pump inlet incorporates a wire mesh filter to protect particles from entering the pump and an integral non-return valve which prevents any oil suck back and pressure increase in the vacuum system. The vacuum system is therefore isolated under all operating conditions, even in the event of inadvertent pump rotation reversal. Lubricating oil is continuously filtered via a particular filter which extends the periodic routine maintenance. The pump outlet incorporates an oil separator system to ensure an absolute minimum of oil mist throughout the entire working pressure range. In addition to driving the impeller assembly, the electric motor also drives its own cooling air flow over the cooling fins. The cooling air is ambient, drawn by the cooling fan from the plant room.

Anti-vibration pads are fitted under the vacuum pump supporting feet to minimize the transmission of vibrations.

Each vacuum pump is exhausted separately. It is recommended to install separate exhaust pipes to the outside of the building. If the exhausts are manifolded together during installation, suitably sized non-return valves must be fitted to the discharge of each pump. The discharge pipe work should be of a size so as not to cause back pressure. The overall back pressure, taking into account outlet pipe length, height and other pressure losses may not exceed 60 mbar (45 mmHg) for a running pump. If it does, the exhausts shall not be manifolded with non-return valves and shall be led outside separately.

A drainage trap is also fitted to collect any liquids formed by condensation. During operation, the bacterial filter prevents contamination within the exhaust discharge system but does not remove offensive odors.

Therefore the Vacuum Plant exhaust discharge should terminate outside the building at high level, preferably above the plant room roof and above other buildings in the immediate area. The discharge should be provided with a cowl or other means of protection against ingress of rain, snow, ice, and wind pressure. A weather proof notice must be fixed at the discharge point, stating: **Medical vacuum discharge - do not obstruct** .

3.6 Bacterial vacuum filters



Duplex bacterial filters complete with drain flasks are arranged in parallel within the system piping immediately prior to the vacuum reservoir and pumps.

The setup for the bacterial filters should be "1+1" or "2+2".

"1+1" means one filter in duty and one filter in standby (smaller vacuum plants). "2+2" means two filters in parallel in duty and two filters in parallel as backup (larger plants).

A manual isolating valve fitted to both inlet and outlet lines to each filter enable one filter to be selected online and the other offline during normal plant operation. This arrangement enables maintenance of either filter without interrupting the vacuum plant operation.

In the "1+1" setup, each clean filter is designed and sized to carry the full plant design flow rate with a pressure drop not exceeding 33 mbar (25 mmHg). In the "2+2" setup, two filters in parallel will handle the full flow. The bacterial vacuum filter elements have penetration levels not exceeding 0.005% when tested by a sodium flame in accordance with BS3928, utilizing particles in the 0.02 to 2 micron size range.



A filter breakdown indicator is fitted across each bacterial filter element to indicate when a filter has reached saturation. This gauge should be checked at weekly intervals and element replacement is required when the gauge indicates 100 mbar (75 mmHg).

Drain flasks are transparent Pyrex with a plastic polymer coating inside and out to prevent damage by accidental knocks and will contain any liquid even if the glass is broken. They are suitable for sterilization and incorporate manual isolating valves. Bacterial filters lose their effectiveness if allowed to become wet, therefore any liquid within a drain flask necessitates filter element replacement.

3.7 Pressure sensors

Different pressure sensors and switches are installed to measure the vacuum level at different positions in the pipeline system (see the schematic overview in [Plant description](#)).

The main pressure feedback is provided by the pressure transmitter PT02 which is installed at the pipeline connection point (upstream of the filters). A backup pressure transducer, marked PT01, is installed directly downstream of the filters. These two sensors also serve to calculate the filter saturation resulting in increased pressure drop.

Each pump inlet is also provided with a pressure transducer upstream of the non-return valve and a pressure switch downstream of the non-return valve. The pressure switch ensures feedback about whether a pump is operating satisfactory, while the pressure transducer is used to control the pump in Local mode (see chapter [Pump controller operation](#)).

3.8 Pump control units



A controller is installed per pump, ensuring the direct communication with its pump (start / stop commands etc.). The supply cables - per pump - are to be connected to these cubicles and the necessary transformer and fuses are provided (see service diagram). An ampere meter on the front side enables to monitor the drawn motor current. A Local/LAN (LAN= Local Area Network) switch makes it possible for the user to swap a pump to Local mode

(see chapter [Pump controller operation LAN/Local control](#)).

The main switch isolates a pump and its cubicle components from the main supply. The cubicle incorporates a thermal protection overload device (F21), which is selected to the pump full load current rating. The thermal protection overload device also monitors the electrical power supply and phase input. In the event of a fault, the overload device breaks the circuit to the pump, which will not operate. Once the fault has been diagnosed and rectified, the overload can be reset inside the cubicle.

On the controller itself, information about the pump is shown (see chapter [Interface icons and menu structure](#)). LED's indicate power supply, automatic operation, service warning and fault condition. The software is explained more in detail in chapter [Scrolling through all screens](#).

3.9 Central control unit



A central controller is connected to the pump controllers through a CAN system. A 210-230 V supply needs to be connected to this cubicle, wherein the necessary transformer and fuses are foreseen (see service diagram). The central controller is based on a master control system referred to as ES-VAC.

The central controller monitors the pressure at the pipeline connection point and sends start / stop commands to the pump controllers based on an even-wear, 11P/11T algorithm. It also tracks the pressure drop over the filters and warns when service is required. It receives information about the pumps, groups it into a clear overview (see chapter [Interface icons and menu structure](#)) and transmits the appropriate alarms to the screen and to potential free output contacts. LED's are provided to indicate power supply, automatic operation, service warning and fault condition. The software is explained more in detail in chapter [Central controller operation](#).

4 Installation

4.1 Introduction



Installation of a medical vacuum plant must be carried out by suitably qualified and competent personnel who fully understand the standards required when working on a piped medical gas distribution system and are conversant with the information contained in this Instruction book. Installation must be carried out strictly in accordance with the specific installation proposal (see chapter [Installation proposal](#)) and service diagram issued with the plant.

The mVAC must be installed within a plant room which provides adequate ventilation for the cooling of electric motors, bearing in mind that approximately 75% of all energy consumed is dissipated into the plant room as heat. At least 500 mm must be allowed between the plant and any walls or other obstructions and additional headroom is required to enable installation. Specific plant dimensions must be taken in to account especially where access is limited. Install the unit in an area where the noise levels do not cause an inconvenience. When bolting the unit to the floor, take into account that the hole diameters in the frame are between 10 mm and 13 mm.



Upon installation, take into account the warnings provided in chapter [Installation warnings](#).

4.2 Installation notes



Special attention should be taken for all next points.

1. Portable and mobile RF communications equipment can affect the mVAC. They should be used no closer to any part of the mVAC, including cables, than the recommended separation distance calculated from the equation applicable to the frequency of the transmitter (See EN 60601): The following minimum distances are recommended:

Rated maximum output power of transmitter (W)	Minimum separation distance between portable/mobile RF communications equipment and the mVAC (m)		
	150 kHz to 80 MHz	80M Hz to 800 MHz	800 MHz to 2,5 GHz
0.01	0.035	0.035	0.23
0.1	0.11	0.11	0.73
1	0.35	0.35	2.3
10	1.1	1.1	7.3
100	3.5	3.5	23

Field strengths from fixed RF transmitters, as determined by an electromagnetic site survey, should be less than the compliance level in each frequency range (performance

criteria A, level 3 limit).

- The mVAC is intended for use in the electromagnetic environment specified below. The customer or user should ensure that it is used in such an environment.

Emissions test	Compliance	Electromagnetic environment
RF emissions CISPR 11	Group 1	The mVAC uses RF energy only for its internal function. Therefore, its RF emissions are very low and not likely to cause any interference in nearby electronic equipment.
RF emissions CISPR 11	Class B	The mVAC is suitable for use in all establishments including domestic establishments and those directly connected to the public low-voltage power supply network that supplies buildings used for domestic purposes.

Immunity test	IEC 60601 test level	Electromagnetic environment
Electrostatic discharge (ESD) IEC 61000-4-2	+/- 6 kV contact +/- 8 kV air	Floors should be wood, concrete or ceramic tile. If floors are covered with synthetic material, the relative humidity should be at least 30%.
Electrical fast transient/burst IEC 61000-4-4	+/- 2 kV for power supply lines +/- 1 kV for input/output lines	Mains power quality should be that of a typical commercial or hospital environment.
Surge IEC 61000-4-5	+/- 1 kV line(s) to line(s) +/- 2 kV line(s) to earth	Mains power quality should be that of a typical commercial or hospital environment.
Voltage dips, short interruptions and voltage variations on power supply input lines IEC 61000-4-11	< 5% mains voltage (< 95% dip in mains voltage) for 0,5 cycle 40% mains voltage (60% dip in mains voltage) for 5 cycles 70% mains voltage (30% dip in mains voltage) for 25 cycles < 5% mains voltage (> 95% dip in mains voltage) for 5 sec	Mains power quality should be that of a typical commercial or hospital environment. If the user requires continued operation during power mains interruptions, it is recommended that the mVAC be powered from an uninterruptible power supply (UPS) or institutional stand-by generator.
Power frequency (50/60 Hz) magnetic field IEC61000-4-8	3 A/m	Power frequency magnetic fields should be at levels characteristic of a typical location in a typical commercial or hospital environment.

- The mVAC shall be installed in an environment where the conditions specified in chapter [Reference conditions and limitations](#) are not exceeded. It shall be protected from rain, snow or other precipitation and the distances to walls as specified shall be respected.
- Make sure that the environment is not potentially explosive.
- Make sure that the ambient condition limits specified in chapter [Reference conditions and limitations](#) are not exceeded during the plant lifetime and that they comply with the protection class of the drive motor.
- Make sure that the vacuum pumps, pipes, filters, and cubicles can neither inadvertently or intentionally be stepped on and cannot be used as support for heavy objects, and cannot be

hit by falling objects.

7. Make sure that no temperature sensitive parts (plastic, wood, cardboard, paper, electronics) will touch the surface of the vacuum pumps.
8. Make sure the installation location is vented such that a sufficient cooling of the vacuum pumps is warranted (see chapter [Design data](#)).
9. Make sure that the vacuum pumps will not be touched inadvertently during operation.



During operation the surface of the pump may reach temperatures of more than 70 °C, risk of burns.

10. Make sure that the oil sight glass will remain easily accessible.
11. Make sure that the oil drain port, oil filter and oil fill port will remain easily accessible.
12. Make sure that the power supply is compatible with the data on the nameplate of the drive motor.
13. Electrical installation work must only be executed by qualified personnel that knows and observes the following regulations:
 - BS 7671
 - IEC 364 or CENELEC HD 384
 - IEC-report 664
 - national accident prevention regulation
14. Before disconnecting any piping, pneumatically isolate the section and slowly in-bleed air to raise the pressure to atmospheric pressure. Do not suddenly open any isolating valve that may cause rapid pressure release (increase). Open valves slowly and allow sufficient time for pressure to stabilise.
15. A checklist / logbook will be made wherein the installer will mark the adherence of the installation to the following paragraphs:
16. Mechanical positioning (see [Installation proposal](#)).
 - Piping connections (see [Installation proposal](#)).
 - Electrical connections (see [Electrical connections](#)).
 - Pre-start inspection (see [Pre-start inspection](#)).
 - Electrical functional check (see [Electrical functional check](#)).
 - Pneumatic settings (see [Setting the pneumatic system](#)).
 - Automatic operation and leak check (see [Automatic operation & leak check](#))Transportation should be carried out according to section [Transporting](#).

4.3 Mechanical installation

4.3.1 Transporting

Once the unit is unpacked from the crate it can be transported by forklift or by crane.

Forklift: the forklift arms should be placed underneath the lowest plates on which the pumps are mounted. Pay attention to position the forklift arms for optimal weight distribution.

Crane: use all lifting eyes provided and pay attention to put equal tension on all lifting chains (if applicable).

4.3.2 Dimension drawings.

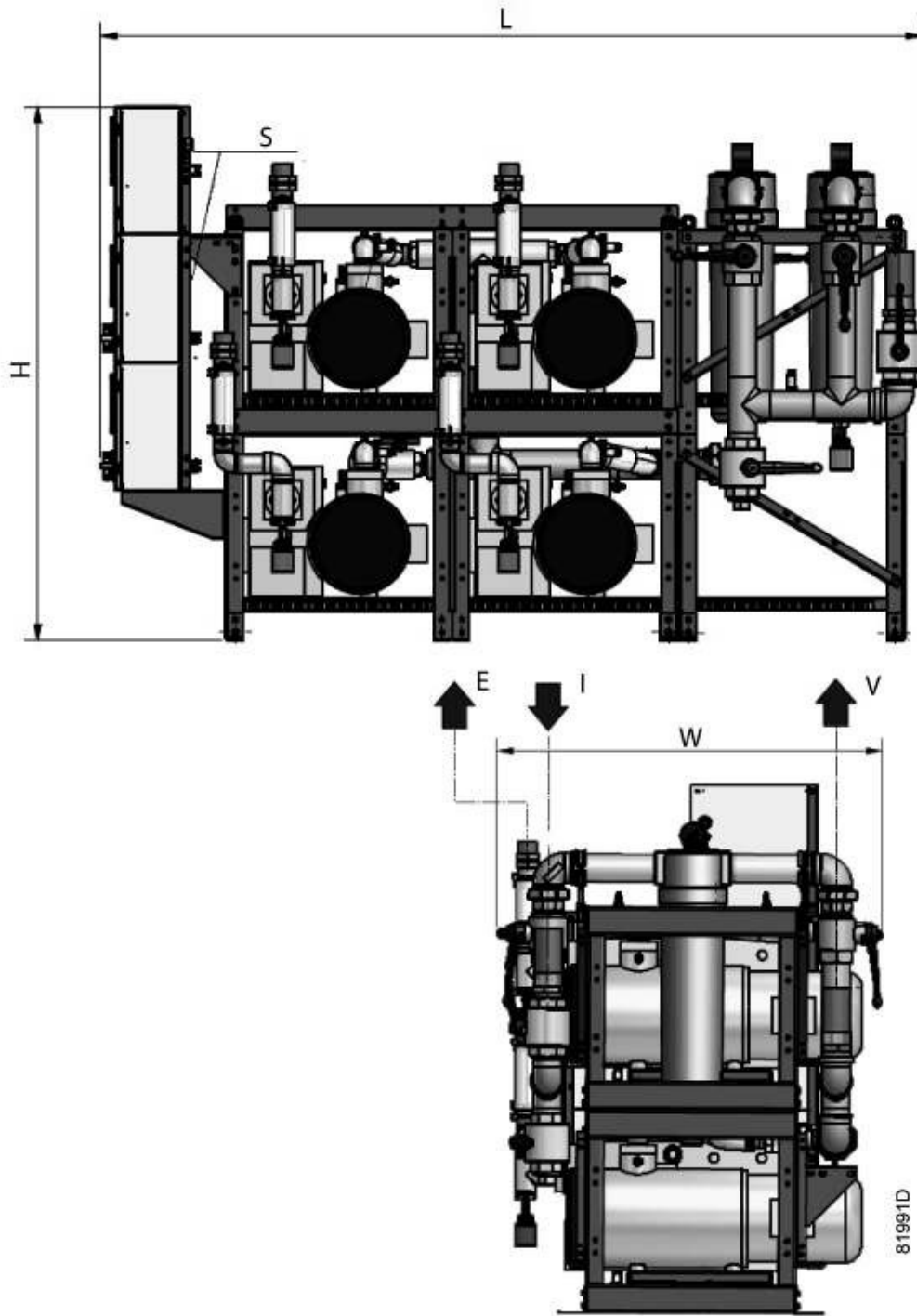

	L	W	H	Ø I	Ø E	Ø V
mVAC 1000 Q 0201 50HZ VV CE	1910	980	1700	54	54	54

Dimension drawing (side and back view) of mVAC 1000 Q as example

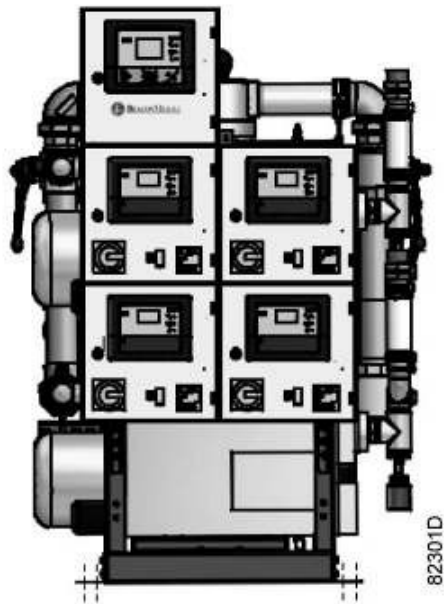
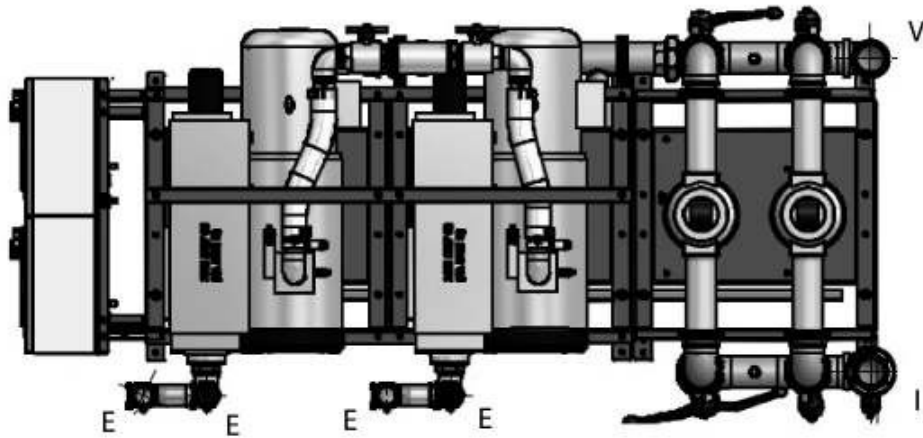

Dimension drawing (front and top view) of mVAC 1000 Q as example

I	Inlet connection
E	Exhaust connection
S	Supply cable connection
H	Height
V	Vessel connection
W	Width
L	Length

Dimension drawings for other installation variants are available on request. Contact BeaconMedaes.

4.3.3 Installation proposal

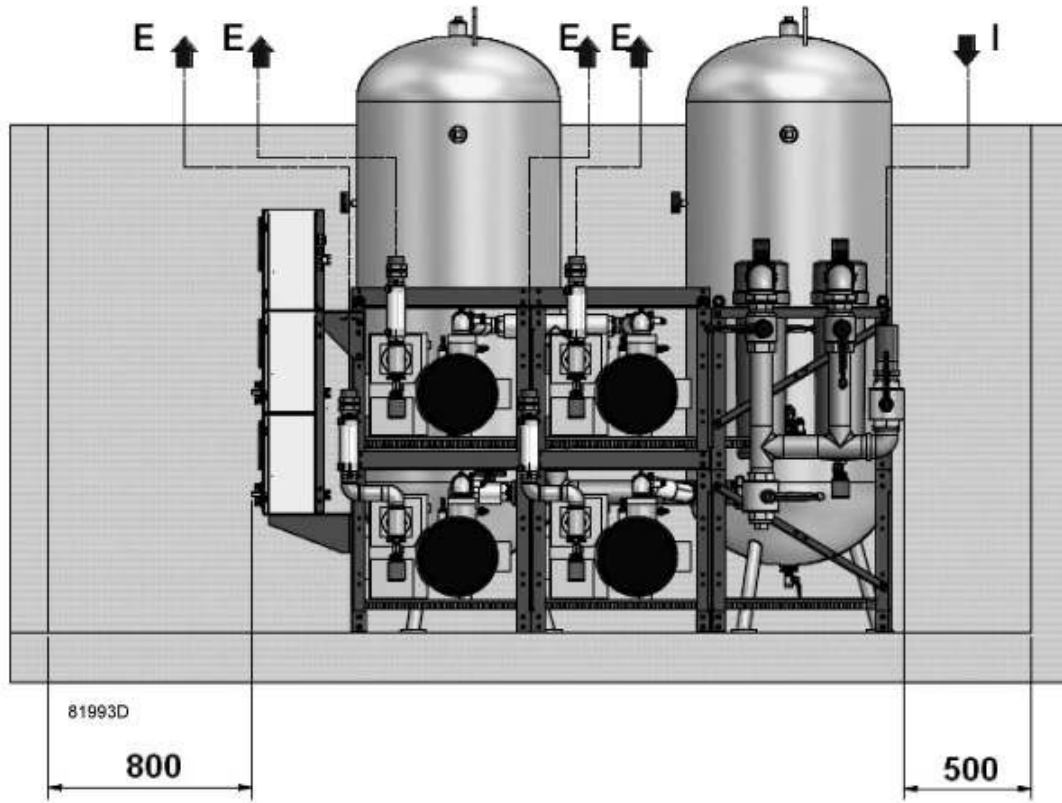

Installation proposal (side view) of mVAC 1000 Q as example

I	Inlet connection
E	Exhaust connection

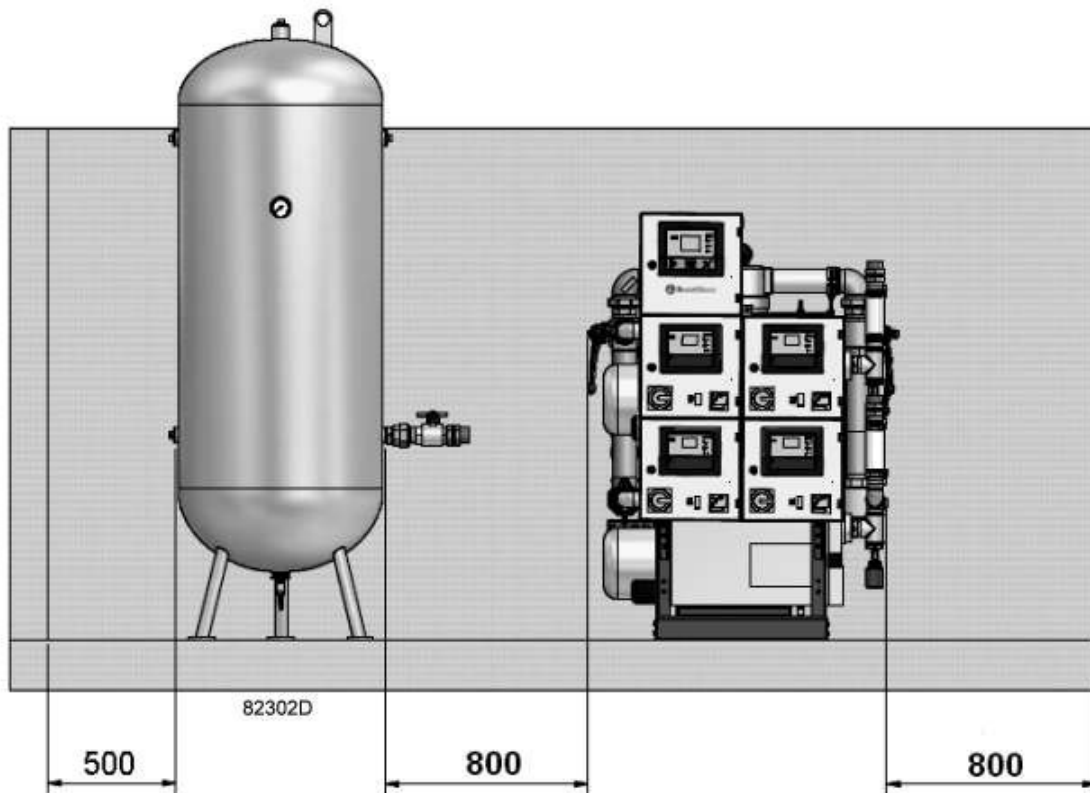

Installation proposal (front view) of mVAC 1000 Q as example

Installation proposal drawings for other installation variants are available on request. Contact BeaconMedaes.

For maintenance and cooling purposes it is recommended to respect the installation proposal for the specific type of mVAC.

1. Move the frame mounted unit into position and drill the floor to receive anchor nuts.
2. Fit mounting bolt anchor nuts into the floor. Fit mounting bolts, washers and nuts and fully tighten down. If the device must be installed with or connected to other medical devices or equipment in order to operate as required for its intended purpose, sufficient details of its characteristics must be obtained to identify the correct devices or equipment in order to obtain a safe combination.
3. Take the vessel connection parts (in loose box, if applicable) and mount them on the vessels.
4. **Connecting piping.** Remove the transport protection caps from the pipes. Check that no ingress has occurred, if necessary clean the pipes. Clean the piping network before brazing. Connect the distribution pipeline installation to the suction inlet. The connecting pipe work must be secured to give added stability. Each vacuum pump incorporates its own exhaust pipe, preferably to be routed separately to discharge into a safe area (see also the notes provision in chapter [Installation notes](#)). The flexible outlet hose will not support the weight of the connecting pipe work. The connecting pipe work must be secured to give added stability. The diameter of the outlet pipe must be large enough to avoid pressure buildup. Back pressure has a negative impact on the performance of the pumps and must be limited as much as possible (max. 60 mbar).
5. Take the drain flasks (inside the cubicle, or in loose box) and mount them on the bacterial filters and exhaust using the plastic washer provided. Check that biological warning labels are attached at each drain flask.



Warning label, biological hazard

4.4 Storage

	If the medical vacuum plant installation is going to be stored, protective measures must be taken.
---	--

- Protect the mVAC against dust and moisture. Store in a clean, cool, dry and well ventilated area.
- Make sure that the medical vacuum plant installation is not subject to vibration.
- If the vacuum plant installation is stored in packing, put some vapour corrosion inhibitor (VCI) paper into the packing.
- If the vacuum plant installation is stored for one year or more, consult BeaconMedaes.

4.5 Electrical connections

On larger vacuum plants, the filter module comes apart and needs to be connected to the pump frame. Connect the sensor cables of the ES VAC controller cabinet (marked PT01 and PT02) to the sensors on the filter piping: connect PT01 to the pressure sensor downstream the bacterial filters (backup sensor) and PT02 to the pressure transmitter upstream the bacterial filters measuring the net pressure.

Consult the service diagram (it can be found inside the cubicles) and verify the motor data plates. Ensure that the power supply is off and correctly isolated before connecting to the cubicles. All wiring must be in accordance with IEE regulations. Cable sizes and fuses given in chapter [Electrical cable size](#) are recommendations. All cable sizes and protective devices must be sized by a qualified electrician.

The mVAC requires a separate power supply for each vacuum pump, preferably from an essential circuit, and requires a 210-230 V AC supply to the central controller cubicle.

Check that the central controller power LED is lit and the controller screen is operational when the 210-230 V supply is connected.

Earth the vessels and other piping as required.

Usually it is required to have a central alarm panel (in the engineering control room or telephone exchange etc.) Therefore potential free contacts (with the alarm signals) are foreseen in the central controller cubicle. Provide electrical wires between the central alarm panel and the mVAC and connect them according to the service diagram provided.

Set up the alarm panel and carry out the alarm test according to [Central controller operation](#).

When in normal status, the alarm signals to the alarm panel are forced closed and when an alarm is triggered, they open. This also means that all alarms will trigger at the central alarm panel when power supply to the central controller is lost

5 Commissioning

5.1 Introduction

Commissioning a medical vacuum plant must be carried out strictly in accordance with the following procedures, which are designed to ensure that the installation is correct and ensure that the mVAC operates correctly. The full commissioning procedure must be carried out after the installation before the system is brought into use. The relevant sections of the commissioning procedure must be repeated following major component replacement or whenever the plant operation or performance is suspect. Commissioning must only be undertaken by suitably qualified and competent personnel who are fully conversant with the information contained in this manual. It is recommended that for a full commissioning procedure, the following paragraphs are carried out in strict sequence. This ensures that at each step the plant is correctly set for the next procedure.

Where applicable, a work permit must be obtained before commencing any work on the medical vacuum system.

These procedures are designed in accordance with EN 7396-1 (e.g. integrity of the pipeline installation, check system design performance and functionally test all components).

5.2 Pre-start inspection

The pre-start inspection is essential to ensure that all components are secure, correctly assembled and that no damage occurs to the plant during initial start-up. The procedure to carry out the pre-start inspection is as follows:

1. Ensure that all electrical power supplies to the plant are off and isolated at the controllers (isolator switches turned OFF).
2. Check the rating of the power supply fuses and fuses in the controller cubicles.
3. Check the security of all components inside the cubicles and examine all connections. Inspect for any obvious damage and rectify if necessary.
4. Check the security of the electrical connections between the vacuum pumps and their respective control cubicles. Check the security of the electrical connections between all cubicles. Ensure that all exposed wiring is correctly routed and secure.
5. Check all external piping connections for security and damage with special attention to flexible hoses.
6. Verify on the sight glass of all pumps that the oil reaches the upper half of the glass, if necessary add oil.
7. Fully close all ball valves.
8. Ensure that the vacuum plant inlet is correctly connected to the distribution system. Ensure that the distribution system is isolated from the plant by closing the distribution system ball valve at the inlet connection point.
9. Ensure that each vacuum pump is connected to the exhaust system and that there are no closed ball valves present or other elements blocking the exhaust.
10. Ensure that all loose articles are removed from the vicinity of the plant.
11. Check the drain flasks for damage to the bowl or connection, order spare parts if needed.
12. Where applicable, check that the pipeline installation is correctly identified and labelled with identification tape at 10 metre intervals and on both sides of any dividing wall.

5.3 Electrical functional check

Following the initial electrical power connection and every time the electrical power supply connections have been disturbed for any reason, all electrical connections must be checked for security and the electrical functional check must be carried out.

1. Verify that each Local/LAN switch is set to Local. Jog each motor briefly by switching On and Off the isolator switch on the pump control cubicles, while checking the rotation of the corresponding pump (cubicle and pump are marked with the same number). The correct rotation is marked by an arrow on the pump. If the rotation is wrong, switch off the pump immediately. Switch off and isolate the power supply and swap 2 phase connections in the cubicle. Carry out the procedure again to check for correct rotation. Check that each vacuum pump operates normally without any unusual noise or vibration. Verify that the ampere meter registers approximately full load current (see [Fuse values](#)).
2. If a motor doesn't rotate during this check, check the connections in the connection box on the motor and check the connections inside the cubicle. Check the overload settings and the fuses (section [Fuse values](#)). When the problem is corrected, carry out the rotational check again.
3. Check that the central controller power LED is lit and the controller screen is operational when the 210-230 V supply is connected. Check that the pump controllers powered LED's are lit and the screens are operational when the isolator switches are On.

5.4 Setting the pneumatic system

Prior to checking the automatic operation, the pneumatic system must be selected as follows:

1. Fully open the drain valves at the exhausts of each pump.
2. Fully open the valves at the inlets of each pumps.
3. Fully open the valves at each vessel connection.
4. Fully open the valves before and after the lead bacterial filter(s).
5. Fully close the valves before and after the stand-by bacterial filter(s).
6. Fully open the drain valves at the bottom of the bacterial filter(s).
7. Fully close the (full flow) test connection ball valve.
8. Fully close the vessel drain valves.
9. Fully close the inlet connection valve which connects the plant to the distribution piping while proving the plant operation (see: [Automatic operation & leak check](#)).
10. After proving the plant operation, making sure that all terminal units are correctly fitted, and after successfully completing the pipeline carcass pressure test, the inlet connection ball valve can be opened.

5.5 Automatic operation and leak check

The following initial start-up procedure ensures that the plant is set to operate normally and the vessel is evacuated to a vacuum level of at least -870 mbar(e) (-653 mmHg).

1. Set the Local/LAN switch to LAN on all pump controllers.
2. Power the central controller and proceed to chapter [Central controller operation](#) to start the software.
3. Set all isolators to On, powering the complete system.
4. Observe that the plant emergency and pressure fault alarms are active.
5. Observe that the pumps are being called and the pressure on the controllers approaches vacuum. Open the test connection (unplug the plug) slightly to simulate a vacuum flow demand, observe that the pumps respond to maintain vacuum.
6. Ensure that each vacuum pump operates normally without any unusual noise or vibration. Should any fault occur, the respective vacuum pump must be switched off immediately. Refer

- to [Faults and remedies](#) and restart the commissioning.
7. After at least 1 hour, fully close the test connection and refit the plug. Observe the gauge(s) on the vessel(s) until a vacuum is reached. At this point all pumps should stop.
 8. Observe that the alarms are now extinguished.
 9. With the complete system at nominal distribution pressure, with the source of supply isolated and with all other valves open, the pressure increase in the pipeline shall not exceed 200 mbar (150 mmHg) after 1 hour. The pressure drop shall be corrected for variations due to temperature according to the ideal gas laws (see EN 7396-1 annex E). In case the pressure increase in 1 hour is greater, close off sections of the pipeline, track leaks (audibly or through other means), and fix them. Then redo the test.
 10. Ensure that the system continues to operate within the design flow rate and that the pumps operate normally with no signs of problems for at least one hour.
 11. Per pump cubicle, read out the value of the drawn nominal current on the amp meter and note down the value.

5.6 Starting the plant

After going through the procedures explained in the previous paragraphs (make sure that the valves are set according to paragraph Setting the pneumatic system), the plant can be left to run automatically. Ensure that all local/LAN switches are set to LAN and that the automatic operation LED's are lit on every controller. See picture at Pump controller overview. Ensure that paragraph Central controller operation is followed to start the software. Follow the guidelines explained in chapter Checks and intervals to ensure trouble free and reliable operation throughout the life of the plant.

6 Operation user guide

6.1 Introduction

As mentioned in chapter [Plant description](#), both a pump controller per pump is foreseen and a central controller which centrally receives information from the pump controllers and sends commands to those pump controllers. The pump controllers are Elektronikon® controllers with text display, while the central controller is an Elektronikon® Graphic+.

Together they form the control system for the medical vacuum plant, performing following functions:

1. Overall plant control and indication
2. Individual pump starting and stopping
3. Plant status monitoring and indication
4. Alarm status signalling

First the individual pump controllers will be explained. In the default situation they are controlled by the central controller, explained in section [Central controller - Interface icons and menu structure](#).

6.2 Pump controller

6.2.1 Interface, icons and menu structure

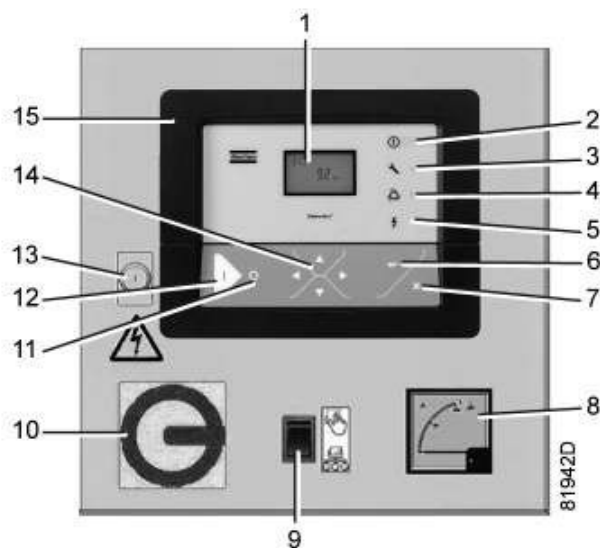





Panel with controller unit.

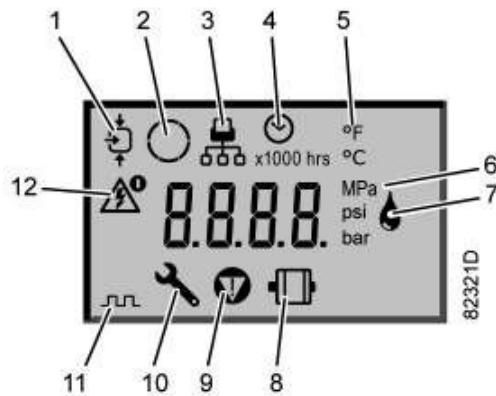















Item	Designation	Function
1	Display	Shows icons and operating conditioning.
2	Warning LED	Is lit when warning is triggered.
3	Service LED	Is lit when a service is needed.
4	Operation LED	Is lit when pump is automatically started and stopped.

Item	Designation	Function
5	Voltage LED	Indicates that the voltage is switched on.
6	Enter button	Confirm action.
7	Escape button	Go to previous screen or end current action.
8	Amp meter	Real-time measurement of the drawn current.
9	Local/LAN switch	Puts the pump in LAN control or in Local control.
10	Isolating switch	Electrically isolates the cubicle from the supply.
11	Stop button	This button stops the pump when in Local mode.
12	Start button	This button puts the pump in automatic operation when in Local mode. The operation LED (3) lights up. Elektronikon® is operative.
13	Cubicle lock	Can be opened with a key to open the cubicle.
14	Scroll buttons	Use these buttons to scroll through the menu.
15	Elektronikon®	Controller



Display on controller unit.

Item	Icon	Appearance	Description
1		Blinking	FTGOL fault (the pump Failed To Go On Load)
2		Rotating	Running
		Steady	Stopped
3		Steady	Under LAN control
		Blinking	Forced Local mode

Item	Icon	Appearance	Description
4	 81538D		Pump cooldown, to prevent too many motor starts per hour (maximum is 20 starts/hour)
	 81112D		When shown, value must be multiplied by 10 to get the actual value.
	 81111D		When shown, value must be multiplied by 100 to get the actual value.
	 81110D		When shown, value must be multiplied by 1000 to get the actual value.
	 81109D		Hours
5	 81108D		Temperature indication (degrees C)
	 81107D		Temperature indication (degrees F)
6	 81116D		MPa (Pressure unit)
	 81115D		Psi (Pressure unit)
	 81114D		Bar (Pressure unit)
7	 83223D	Blinking	Oil level switch (option): indicates the oil level is too low
8	 81542D	Steady	Number of motor starts
	 81542D	Blinking	Motor overload
9	 81540D		Emergency stop
10	 81541D		Service required
11	 82320D	Blinking	Emergency Forced Local mode (triggered by local pressure)
12	 81538D	Steady	Automatic restart after voltage failure

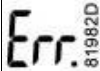
Item	Icon	Appearance	Description
			Sensor error

6.2.2 Scrolling through all screens

Controller panel



Controller panel

Scroll buttons are used to scroll through all screens. The screens are divided into register screens, measured data screens, digital input screens (numbered as <d. In>, <d. 1>, ...), parameter screens (numbered as <P. 1>, <P. 2>, ...), and test screens (numbered as <t. 1>, ...).

During scrolling, the numbers of the screens appear in a consecutive order. For most screens, the unit of measurement and the related pictograph are shown together with the screen number.

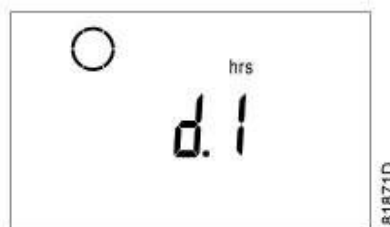

Example (operating hours)

The screen shows the screen number <d. 1>, the unit used <hrs> and the related icon (operation). Press Enter key to call up the number of operating hours.

Overview of the screens

Digital input screens	Designation
<d. In>	Status of the digital inputs
<d. 1>	Running hours (hrs or x1000 hrs)
<d. 2>	Motor starts (x1 or x1000)
<d. 3>	Module hours (hrs or x1000 hrs)

Digital input screens	Designation
<d. 4>	Service timer reading (hrs or x1000 hrs)
<d. 5>	Actual program version

Parameter screens	Designation
<P. 1>	Selection between Local, remote or LAN control (parameter not active)
<P. 2>	Setting a node ID for CAN control (CAN address)
<P. 3>	Settings for IP, gateway and Subnet mask
<P. 4>	Pressure band settings (parameter not active)
<P. 5>	Modifying the service timer
<P. 6>	Setting of unit for temperature (parameter not active)
<P. 7>	Setting of unit for pressure
<P. 8>	Setting for function: Automatic restart after voltage failure
<P. 9>	Selection between Y-D or DOL starting (parameter not active)
<P. 10>	Setting of minimum stop time
<P. 11>	Setting a password

Test screens	Designation
<t. 1>	Display test
<t. 2>	log function

Menu flow

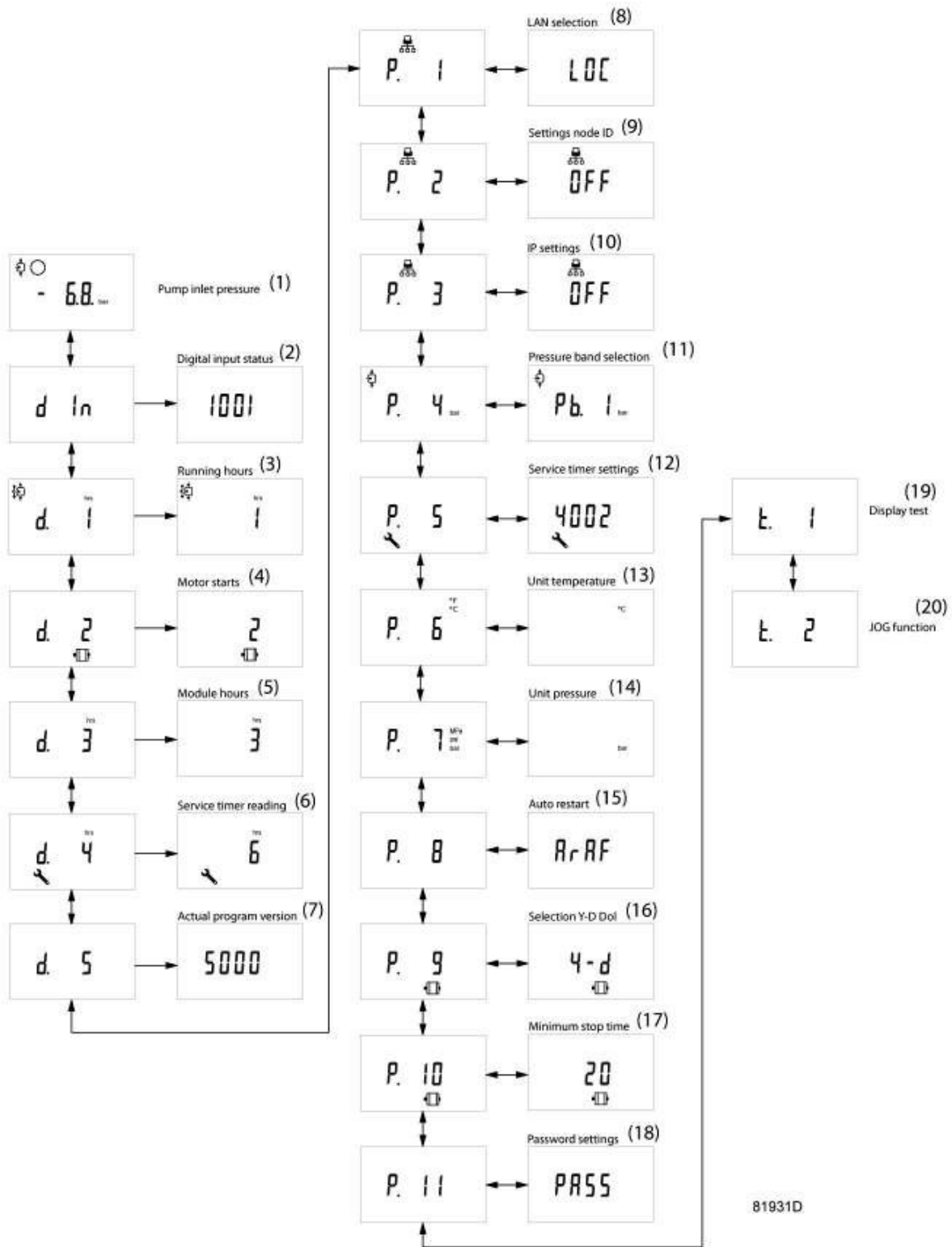

Simplified menu flow

Ref.	Description	Ref.	Description
(1)	Pump inlet pressure	(11)	Pressure band selection
(2)	Digital input status	(12)	Service timer settings
(3)	Running hours	(13)	Unit temperature
(4)	Motor starts	(14)	Unit pressure
(5)	Module hours	(15)	Auto restart function
(6)	Service timer reading	(16)	Selection Y-D DOL
(7)	Actual program version	(17)	Minimum stop time
(8)	LAN selection	(18)	Password settings
(9)	Settings node ID	(19)	Display test
(10)	IP settings	(20)	Jog function

6.2.3 Pump controller operation

LAN/Local control, automatic/manual operation

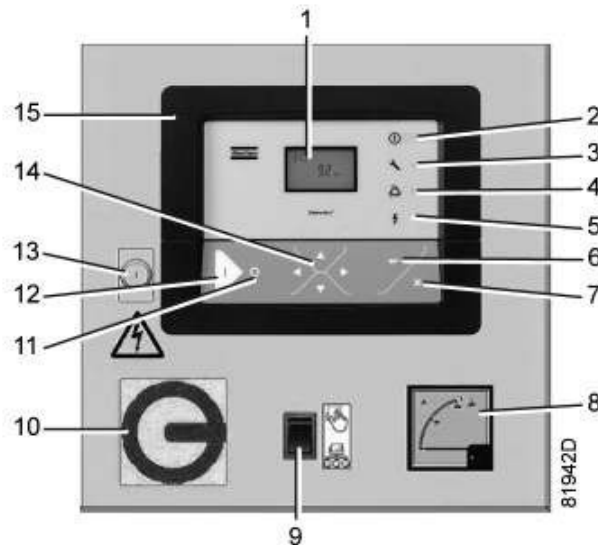





With the Local/LAN switch (9), the user can put the pump either in LAN control or in Local control. By default, the pumps should be in LAN control since this ensures the most efficient operation. The controller maintains the pressure between programmable limits by running or stopping the pumps. When in LAN mode, these commands are relayed by the central controller. When in Local mode, these commands are based on the pressure measured by the transducer located at the inlet of the corresponding pump, see diagram: [Plant description](#).

For maintenance reasons or in case of problems, it is advised to put the pump in Local control. By default, a plant fault alarm is triggered when a pump is set to Local. To prevent this fault from appearing during maintenance, isolate this pump in the central controller software (see [Central controller operation](#)). After having switched to Local control (switch 9), stop the pump by pushing the Stop button (11) and proceed by switching off the isolating switch (10).

To reinstate a pump, re-integrate it in the software, turn the isolating switch to On and put the Local/LAN switch to LAN.

In LAN control, the pump is in automatic operation by default. In Local control, operation depends whether the On or Off button is pressed on the controller (11 or 12). When the On button is pressed, operation is automatic (based on the pump's local pressure sensor). When the Off button is active, the pump will not run, unless the JOG function is activated (see [Scrolling through all screens](#)). In JOG mode, the pump runs continuously until cancel is pressed. The JOG function is only available in Local Off mode.

	 Position of switch (9) LAN control	 Position of switch (9) Local control	
Automatic operation	Pump is automatically started or stopped, based on central controller algorithm	Start button (12) 	Pump is automatically started or stopped, based on local pressure sensor
Manual operation	Not possible	Stop button (11) 	No JOG: pump is stopped JOG: pump runs continuously

Pressure display

The default starting display shows the pressure that is read out from the pump's pressure sensor, regardless whether that pump is running or not.

By scrolling down, the user can read out the running hours, motor starts, module hours, service hours, . in the corresponding submenus (see section [Scrolling through all screens](#)). One by one, the other relevant submenus will be explained hereunder.

Viewing the input status

Entering submenu <d. In>, one can easily verify the status of the input signals (e.g. for troubleshooting). Four digits are displayed, each representing a specific input:

- First digit: Status of the motor overload protection. 1 = OK, 0 = Overload tripped.
- Second digit: Status of the Local/LAN switch. 1 = LAN mode, 0 = Local mode.
- Third digit: Status of the oil level switch (if applicable). 1 = oil level OK, 0 = oil level too low.
- Fourth digit: Status of the FTGOL switch (see [Interface icons and menu structure](#) and [Plant fault](#)). 1 = vacuum not detected, 0 = vacuum detected.

Example: for a pump that isn't running, the following status corresponds to the fact that all inputs are normal: 1111. When a pump is running, this should change to 1110.

Resetting service running hours

When a maintenance interval is expired, the blue service LED is lit (item (3) in section [Interface icons and menu structure](#)).

To reset the service timer after carrying out the required maintenance (see [Oil, oil filter and oil separator change](#)), scroll to the service submenu <d. 4> and press Enter.



Example of running hours on display since last service.

The number of running hours since the last service is shown. Press Enter (enter your password if it is set) and press Enter again to confirm. The service interval defined in <P. 5> will be subtracted, the blue LED will go out and the service warning will disappear.

CAN settings

Submenu <P. 2> can be used to change the CAN address and to turn CAN Off or On.

Normally these settings are set correctly during production and should not be changed. The CAN address is unique per pump and defines the cut-in and delay value in Local mode. The CAN address should correspond to the figure indicated on the label on the pump cubicle.

CAN should be put to Off prior to change the CAN address. Do not forget to put CAN to On after the CAN address has been set.

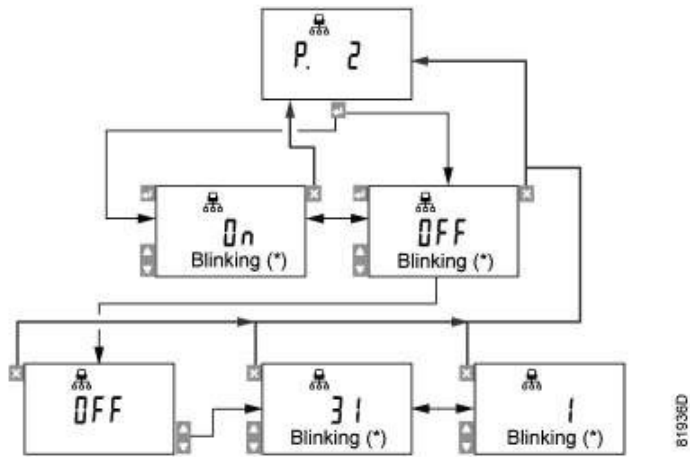

(*) Blinking

IP settings

When scrolling down further to submenu <P. 3>, the IP submenu is accessible. When the user wants to connect to this controller directly through LAN/IP, the settings can be modified according to the following diagram.

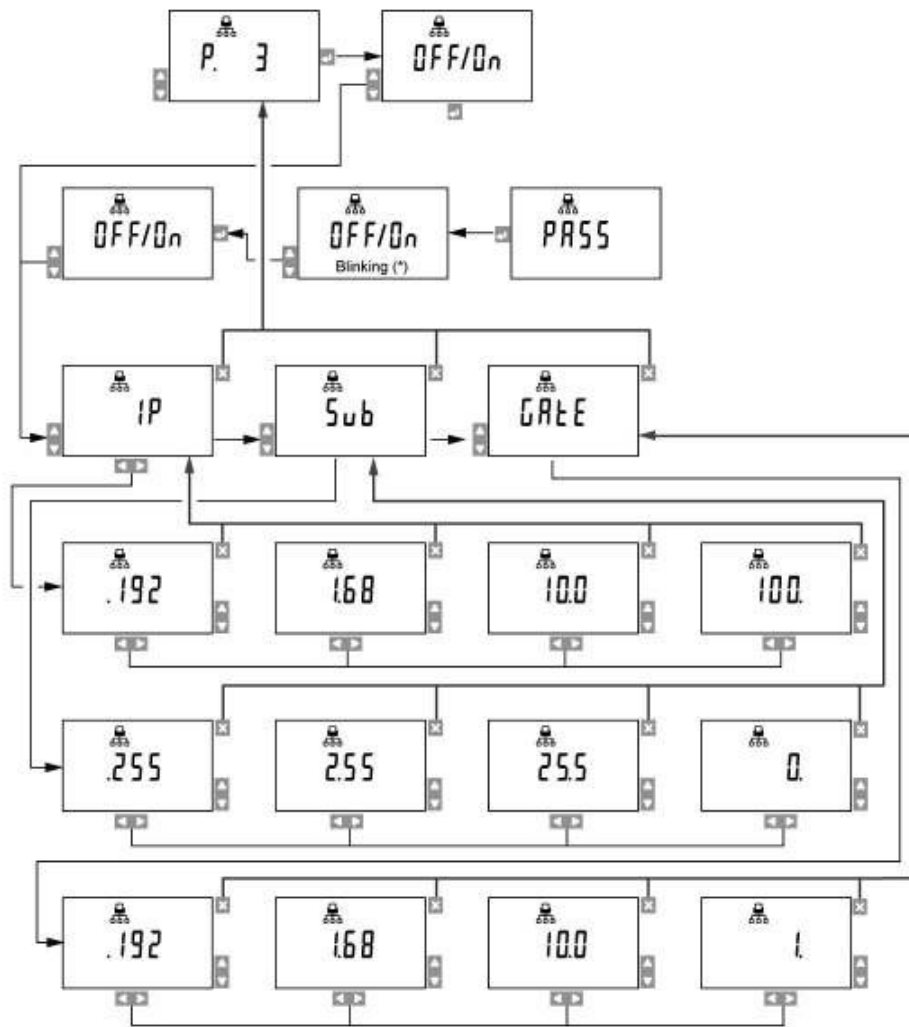

81937D

Changing the temperature unit

Scrolling down further till <P. 6> shows the submenu where the temperature unit can be modified. The actually used unit is shown. Possible settings are <°C> and <°F>.

To change:

- Press Enter button (6) (unit blinks) and use the Scroll buttons (14) to select another unit.
- Press Enter button (6) to program the new unit or press Escape button (7) to return to the parameter screen without changes.

Changing the pressure unit

Scrolling down further till <P. 7> shows the submenu where the pressure unit can be modified:

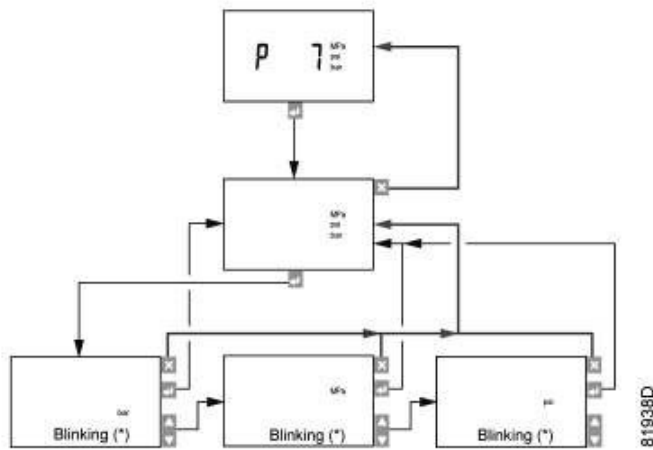

(*) Blinking

Automatic restart after voltage failure

Submenu <P. 8> makes it possible to (de)activate the Automatic Restart After Voltage Failure (ArAF) function on the level of the local controller.

When ArAF is On, a pump in Local mode will restart when the power is reinstated within the selected time frame if it was running before the voltage was interrupted.

To prevent a pump from restarting unwillingly after voltage failure, the following procedure can be followed to disable ArAF:

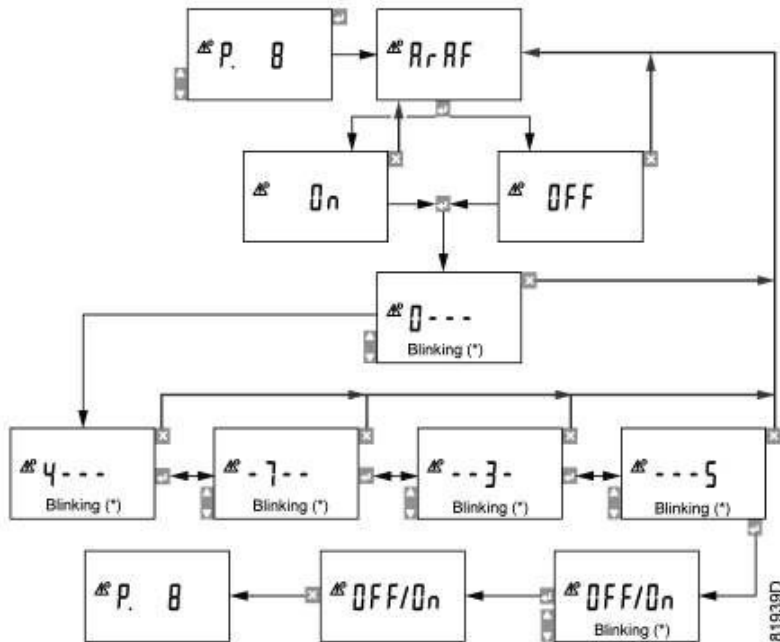

(*) Blinking

Password

Submenu <P. 11> makes it possible to set a password to protect important settings such as service timer and control mode settings.

	Attention: Lost passwords can not be recovered. Save the password carefully.
---	--

The following procedure makes it possible to set a password:

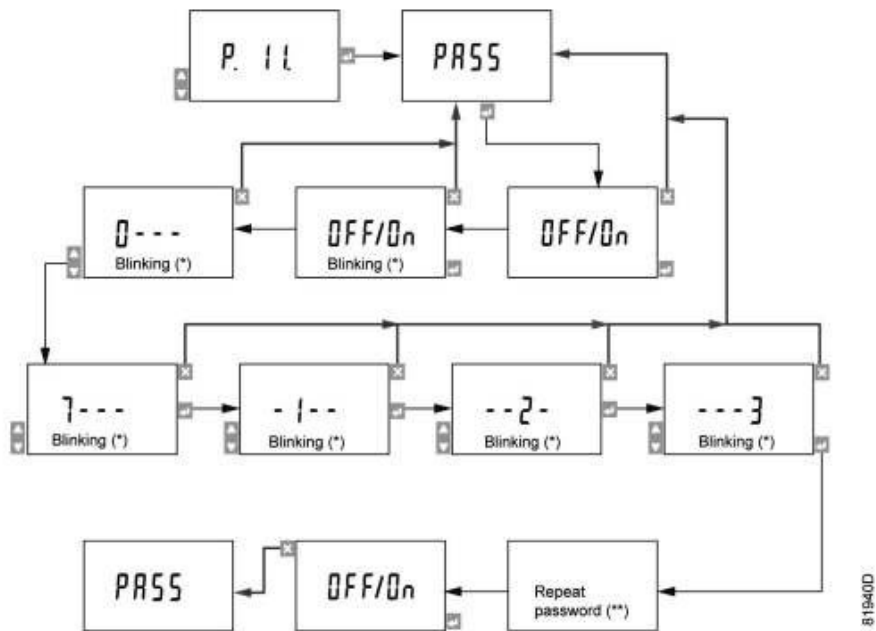

(*) Blinking

(**) Repeat password

6.3 Central controller (ES-VAC)

6.3.1 Interface, icons and menu structure

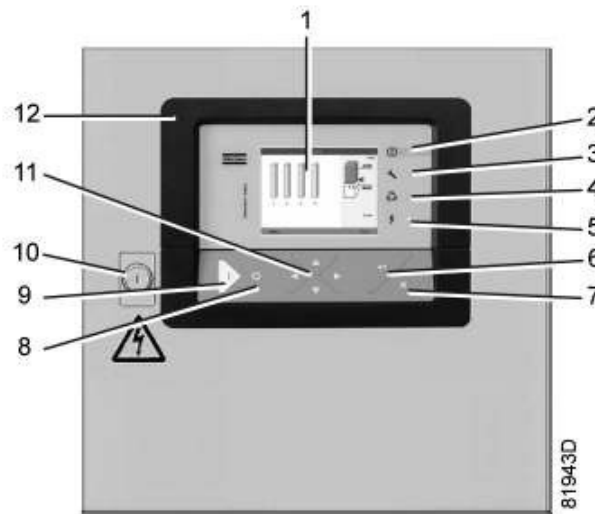

Panel with central controller unit (ES-VAC)

Item	Designation	Function
1	Display	Shows icons and operating conditioning.
2	Warning LED	Is lit when warning is triggered.
3	Service LED	Is lit when a service is needed.
4	Operation LED	Is lit when pump is automatically started and stopped.
5	Voltage LED	Indicates that the voltage is switched On.
6	Enter button	Confirm action.
7	Escape button	Go to previous screen or end current action.
8	Stop button	This button stops the pump when in Local mode.
9	Start button	This button puts the pump in automatic operation when in Local mode. The operation LED (4) lights up and the Elektronikon® is operative.
10	Cubicle lock	Can be opened with a key to open the cubicle.
11	Scroll buttons	Use these buttons to scroll through the menu.
12	Elektronikon® GraphicPlus controller	Central controller (ES-VAC)

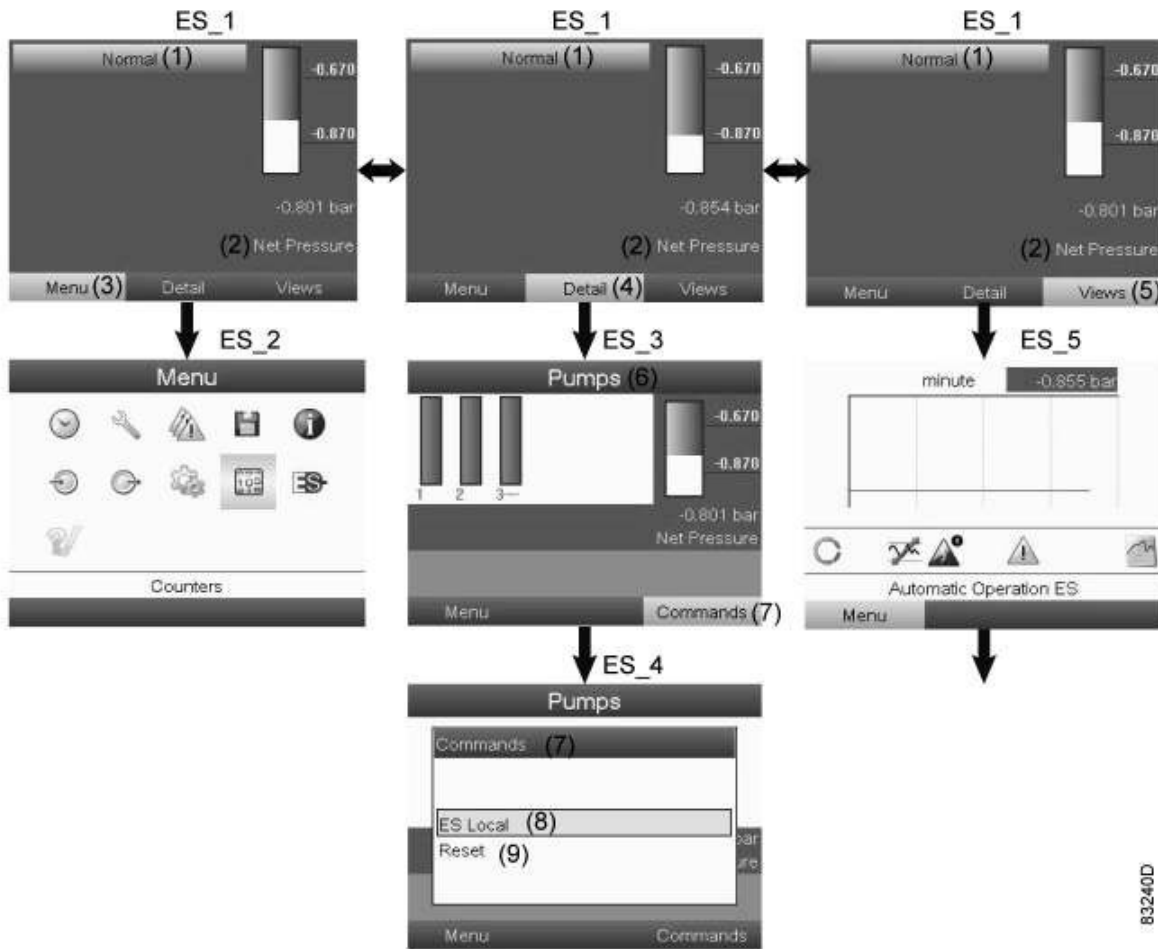

83240D





The main menu flowchart (full access situation)

(1)	Normal	(6)	Pumps
(2)	Net pressure	(7)	Commands
(3)	Menu	(8)	ES Local
(4)	Detail	(9)	Reset
(5)	Views		







Select one of the main tabs (Menu - Details or Views) by using the arrow keys (11) followed by pressing the enter key (6). Now it is possible to select one of the submenus by using the arrow keys (11) and again pushing Enter (6). If you want to revert from a submenu to the main screen, push the Escape button (7).







- Starting screen (ES_1): shows the inlet net pressure and the status of the plant.
- Main menu (ES_2): gives access to the different sub-menus (see [Central controller operation](#)).
- Pump overview screen (ES_3): shows an overview of the plant pumps with their status.
- Command screen (ES_4): Enables the user to start the central controller or force the pumps into local mode.
- View screen (ES_5): enables the user to view the plant information as a graph, as a 2 line input or as a 4 line input.

The symbols used in the pump overview screen are as follows:

Bar graph	Status	Description
	Idle Pump	The pump is idle and ready to be called.
	Lead pump	The central controller has assigned this pump to be the next one to run.
	Called pump, last one called	This pump has last started to run.
	Called pump	This pump is running.

The table below describes the faults. More details in section [Plant fault](#).

Icon	Status	Description
	No valid pump	A pump controller is expected at this CAN address node but not detected.
	No Communication	No reply from the connected pump controller within a pre-defined time.
	No Answer	Connected pump controller is not responding correctly to the commands (e.g. no reaction on a run command).
	Not Available	Pump is stopped and is counting out the Minimum Stop Time to prevent too many motor starts per hour. During this time the pump is not available to the ES control algorithm. (maximum 20 motor starts / hour)
	Pump Shutdown	Pump is in Shutdown condition.
	Failed To Go On Load	The pressure switch at the inlet of the pump detects vacuum when it should not, or doesn't detect vacuum when it should.

Icon	Status	Description
	Overload	The motor draws too much current and the overload has isolated the pump.
	Sensor error or oil level low	In case the pump controller shows the text Err on the display of the pump controller together with this icon on the central controller, the pump has a sensor error. When the pump controller doesn't show this text on the pump controller, the oil level is too low.
	Local mode	The pump has either been manually set to Local, was forced to Local from an ES command or was forced to Local by the Emergency Forced Local backup system.
	Service required	The pump's running hours have surpassed the predefined interval and maintenance must be carried out.
	Isolated	User has isolated this pump controller: it will not transmit faults or alarms
	Blinking	The pump is running in Emergency Forced Local (EFL)

6.3.2 Central controller operation

Gaining full access to all menus

To access certain menus like the Settings, ES, Test and Commands menu, the access key needs to be given. In the Menu screen, navigate to the Settings icon indicated below, enter the following submenu and insert the code <2801>, using the scroll buttons.

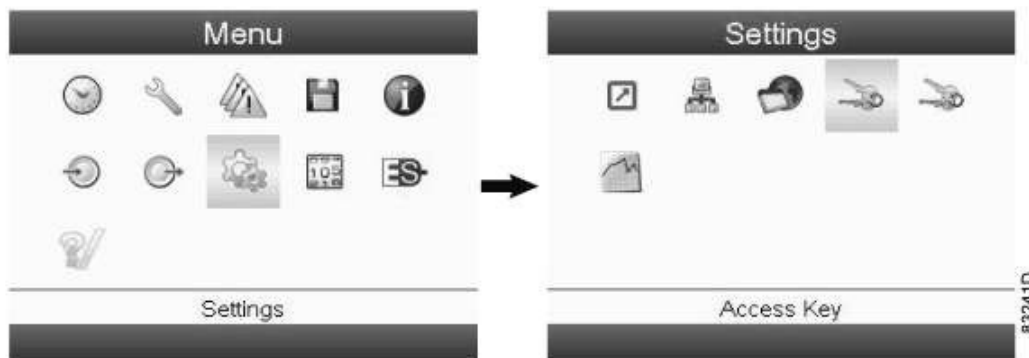

After entering the access code, the user has full access. When no key is pressed during several minutes, full access disappears and needs to be re-entered if required.

Testing the alarms

Before starting the machine, the alarms can be tested. The 3 alarms will automatically cycle for 3 seconds without actual faults. This can be done to test the transmission to the control room alarm display. Navigate to the following submenu and press Enter.

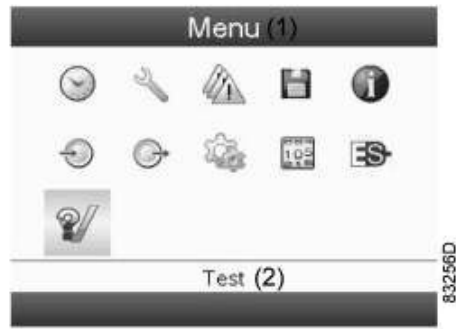

(1)	Menu
(2)	Test

When the test icon is greyed out, the plant needs to be stopped first. Refer to the following paragraphs to stop the ES system.

Setting CAN

These settings are set ex factory and need not to be changed. However, to verify, the following steps can be followed after entering the Settings submenu and then selecting Network (full access needs to be obtained, see above):

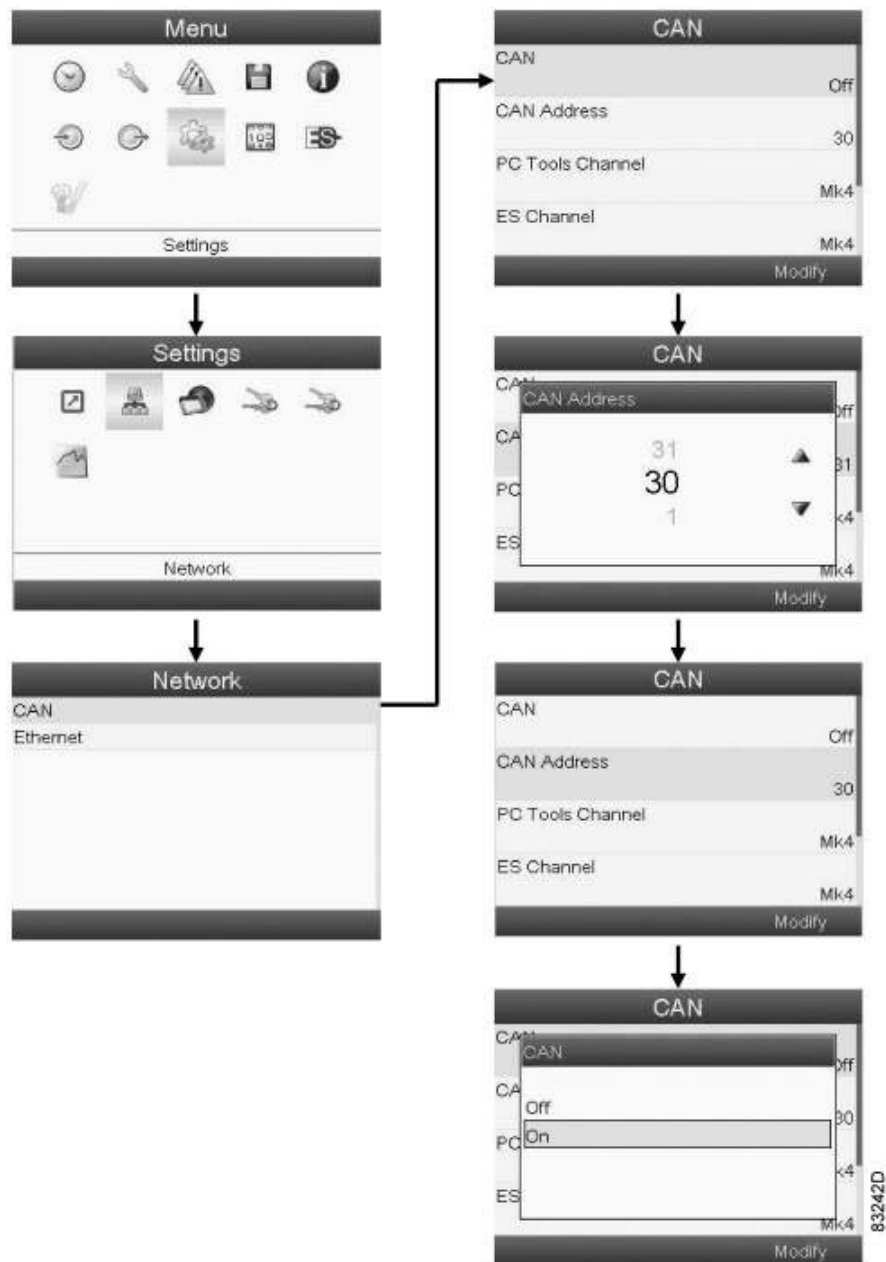

The CAN address should be set to 30 and CAN should be set On.

Communication profile should be set to Mk4.

Setting ES

After commissioning the plant (see [Starting the plant](#)), the ES control system must be started. During production, the system should have been set correctly in the software. To verify, the following procedure can be followed (full access needs to be obtained, see above):

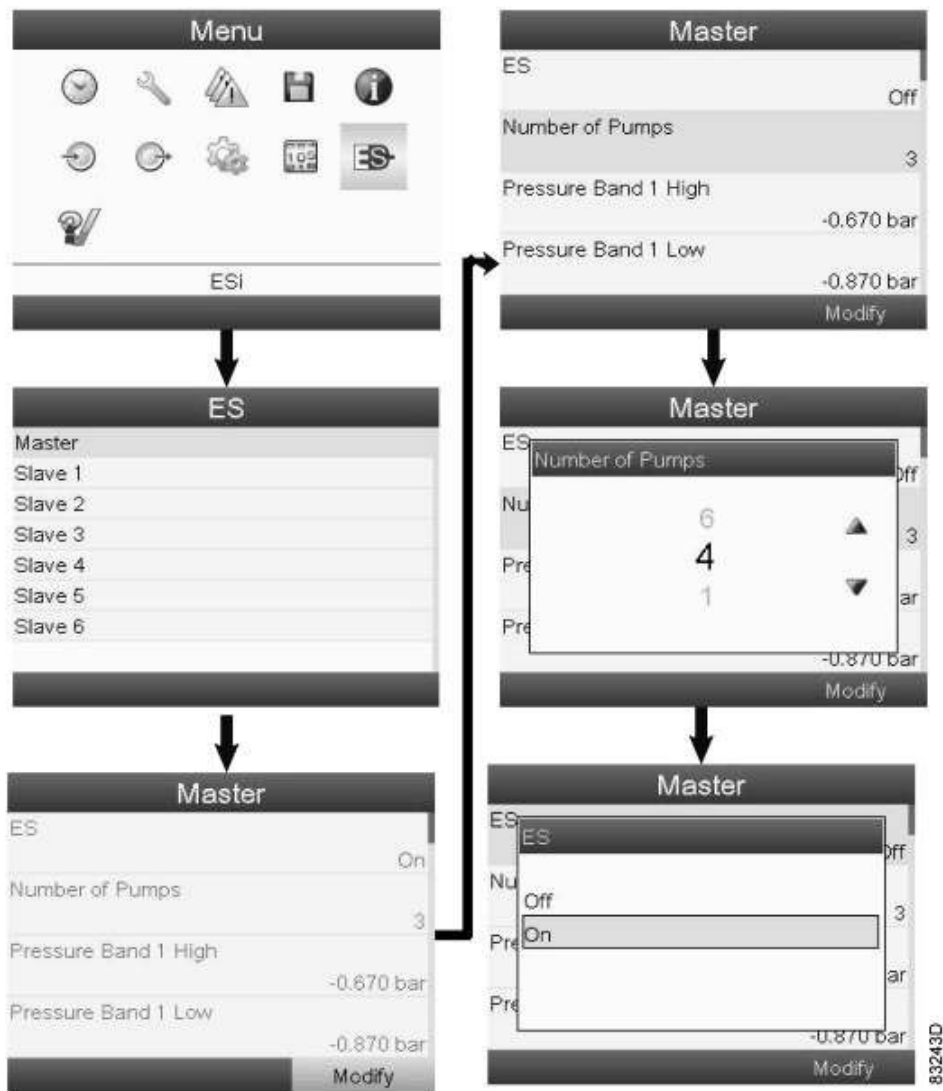

The number of pumps should be set to the actual number of pumps present on your plant and ES should be set On.

Setting the pressure unit

In the Settings, General submenu (full access needed, see above), navigate to *Pressure Unit* and select the desired pressure unit.

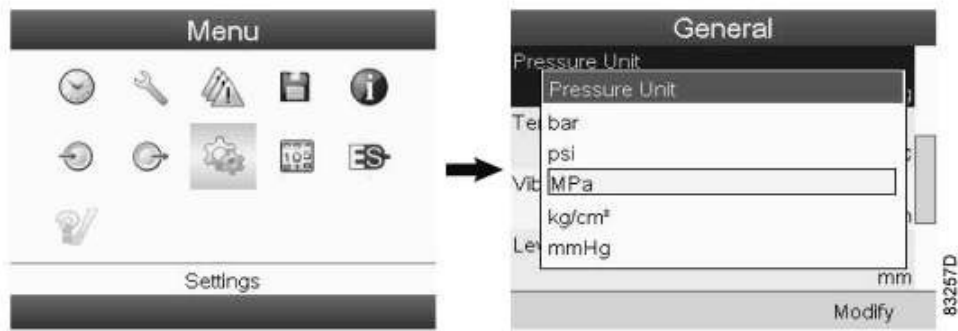

Automatic restart

In the Settings submenu, the submenu of ArAF (Automatic Restart After voltage Failure) is accessible (full access needed, see above). Ex factory, it should be set to Infinite. Contact BeaconMedaes if it is believed these settings should be changed.

Other settings

The following settings can be found under the ES > Master submenu.

In normal circumstances they should not be changed. Please contact BeaconMedaes.

Parameter	Function	Min. setting	Factory setting	Max. setting	Unit
Pressure band X High	To program the maximum setting for pressure band X	0	-0.670	-0.869	bar
Pressure band X Low	To program the minimum setting for pressure band X	-0.671	-0.870	-1.500	bar
Pressure band in use	To select between pressure band 1 and 2	-	1	-	-
Digital Pressure band selection	Enables to change the pressure band in use via digital input	-	Off	-	-
Scheme in use	To define which scheme is in use (see slave parameter scheme x priority)	-	1	-	-
Digital Scheme selection	Enables to change the digital scheme in use via digital input	-	Off	-	-
Forced time	To program the interval at which, if activated by "System Forced", the central controller starts a new pump in case no sequence change has occurred during the interval	1	2	60	hrs
Remote to Local time	To program the time interval between LAN and Local commands from central to pump controllers	2	20	600	sec
Start/load time	To program the time interval between the different start	2	3	600	sec

	commands from central to pump controllers				
Unload time	To program the time interval between different stop commands from central to pump controllers	2	3	600	sec

Parameter	Function	Min. setting	Factory setting	Max. setting	Unit
Delta time	To program the difference in running hours to allow the central controller to decide starting another pump	10	168	672	hrs
Local	If activated, a local command is possible from the commands screen	-	On	-	-
System Forced function	To allow the central controller to force another sequencing by starting a new pump at the interval programmed in "Forced Time"	-	On	-	-
Auto restart	When power recovers within this time, the automatic restart function will be performed. If power recovers beyond this time, no automatic restart will be executed.		Infinite		
Maximum power down time	If ArAF is set to "Active" (e.g. instead of "Infinite"), then the system will only restart automatically within this power down time.	15	20	3600	sec
Sequence method	Equal wear or manual sequence	-	Equal wear	-	-
Operation mode	Change controller to be Local, Remote or LAN controlled	-	Local control	-	
Group sequence X	Only when manual sequence is active. Set up manual sequence.	-	-	-	-
Manual Sequence Shift Up Delay	Only when Manual sequence is active. Time how long it will take to shift the sequence one up.	2	0	600	sec
Manual Sequence Shift Down Delay	Only when Manual sequence is active. Time how long it will take to shift the sequence one down.	2	0	600	sec

The following settings can be found under the ES > Slave X submenu.

In normal circumstances they should not be changed. Please contact BeaconMedaes.

Parameter	Function	Min. setting	Factory setting	Max. setting	Unit
Scheme X priority	To put this pump in a certain priority queue, based on the scheme selected (see master parameter "Scheme In Use")	1	1	6	-
Start/load reaction time	To program the time interval in which the start command from the central controller should result in the pump running	1	40	300	sec
Stop reaction time	To program the time interval in which the stop command from the central controller should result in the pump stopping	1	60	300	sec

Parameter	Function	Min. setting	Factory setting	Max. setting	Unit
Running hours	To adjust running hours for pump X to influence the even wear control algorithm	0	X	500000	hrs
Mode	See below	-	Integrated	-	-
Manual sequence group	Only when Manual sequence is active. Defines to which manual sequence group this slave belongs.	1	1	6	-

Starting

To start the system, after having completed the CAN and ES setup described above, carry out the following steps:

1. Turn the pumps' main switch to On and the Local/LAN switch to LAN. The Emergency Forced Local warning (see [Interface icons and menu structure](#)) and red LED is present on the display since the pressure is above -590 mbar(e). Once the pressure is below -590 mbar (on the display of the pump controller), the Escape button must be pressed on the pump controller (see [Interface icons and menu structure](#)) which will make the warning to disappear and the red LED to go out.
2. Start the ES system (full access mode, see above).

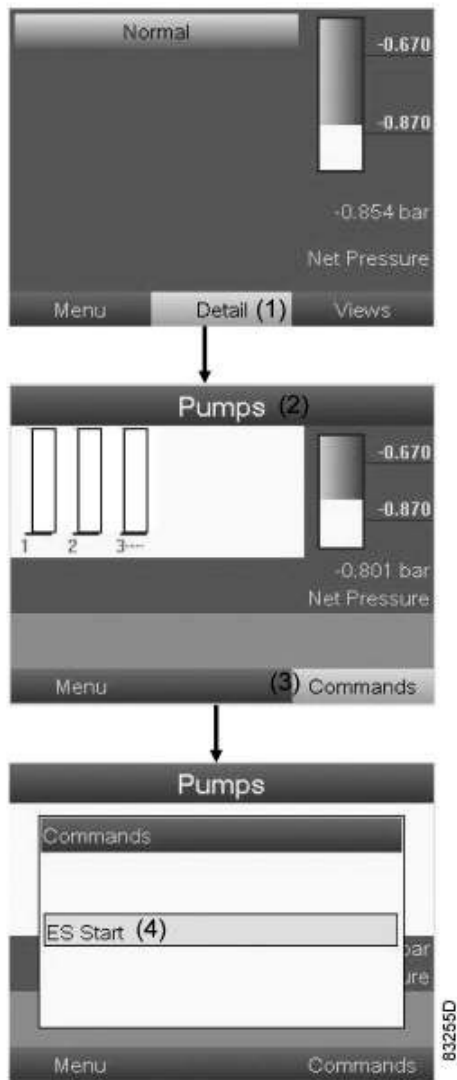

Text on image

(1)	Detail	(3)	Commands
(2)	Pumps	(4)	ES Start

Navigate to the Start button and press Enter. A spinning circle on the display should appear to indicate that the ES system is operating.

Stopping and resetting

To stop a certain pump, see section [Pump controller operation](#). To force all pumps local, go to the commands screen and select the Local button.

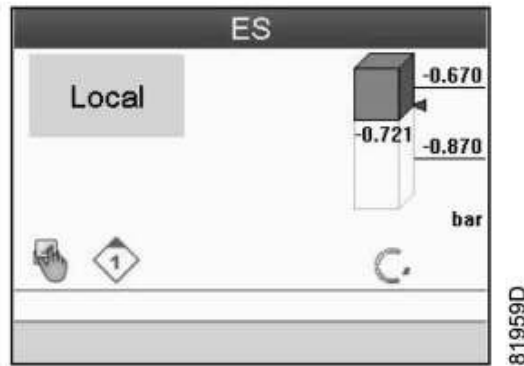

The spinning circle symbol will disappear, indicating that the ES-VAC is not active (controlling the pumps) any more. The pumps are now in *Forced Local Mode*, even though their Local/LAN switch may still be in LAN position. This allows the operator to do maintenance or troubleshooting on the central controller while vacuum is guaranteed by the local pumps.

To reset, after having pressed Local, turn off the ES-VAC (see above), then select On again. Then proceed to paragraph *Starting* to start the central controller, putting it in charge of the pumps again. Alternatively, switch CAN Off and On.

Isolating a pump controller

To carry out maintenance on a pump without transmitting alarms, select the ES submenu from the main menu (requires full access, see above). Browse to the pump that needs to be isolated and press Enter. In the following selection menu, navigate to Mode and select Isolated. Important: after maintenance, this same process shall be followed to select the mode to Integrated again.

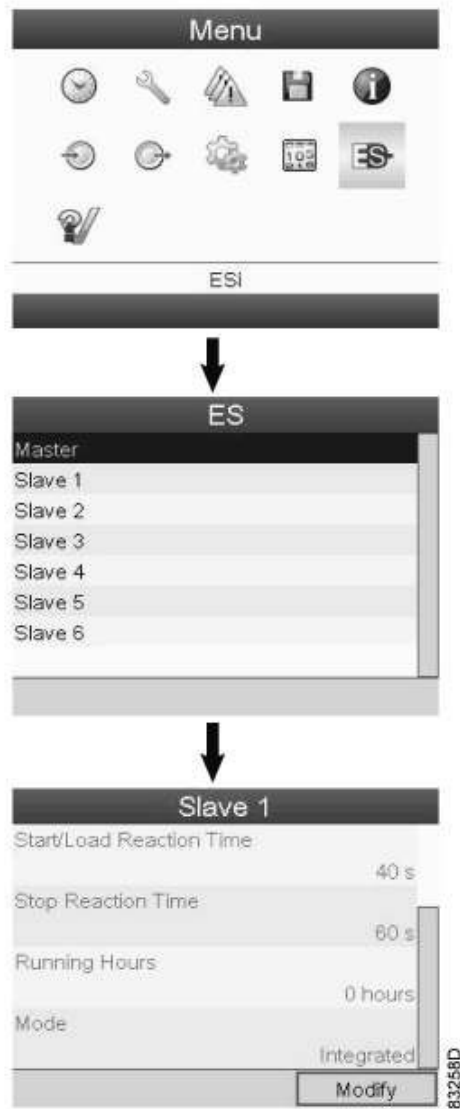

Event history

When an alarm is triggered, the full situation (inputs, outputs, time stamp) is logged into the event history. To take a look, follow the following steps:



The event history keeps track of the last 30 events. To store all events, as well as get a more in-depth and graphical history of inputs and outputs (e.g. pressure), the AirConnect option needs to be installed additionally. Please contact BeaconMedaes.

Viewing information about the central controller

Through the following submenu, information regarding MAC address, software, IP settings, etc. can be viewed.



Viewing the amount of module hours

Through the Counters submenu, the amount of hours that the central controller was powered can be viewed



Viewing the input & output status

The direct inputs of the central controller are the pressures measured upstream (net) and downstream (pump) of the bacterial filters, and consequently the difference thereof (Delta P). The outputs are the alarms or normal status that are transmitted potential free to the hospital control room. "Closed" corresponds to "active".

Through the following procedure, the inputs and outputs of the central controller can be viewed in real time. The configuration of the potential free contact is dual. As such, there is for instance *Plant Fault* and *2nd Plant Fault*. One set of alarms is intended for the BMS (Building Management System), the other set is provided with additional resistors and intended to

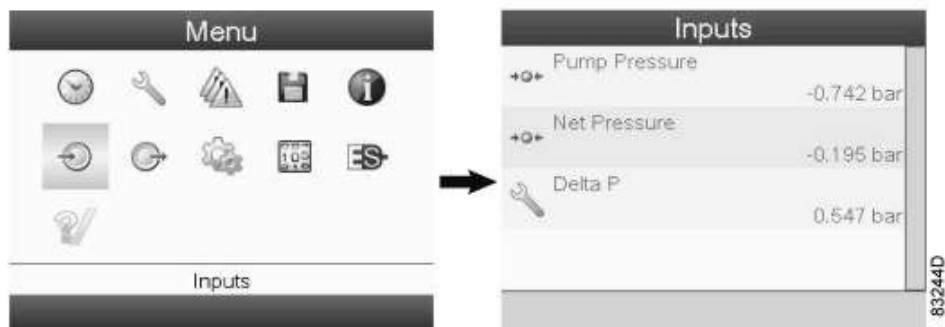

connect to the MP125 (Central Alarm System Medipoint 125 from BeaconMedaes). Consult the service diagram for the correct configuration.



Web browser

Carry out the following steps to set a custom IP address, gateway and subnet mask. After connecting an ethernet cable between your network and the controller, the plant can be monitored on line when browsing to the set IP address.

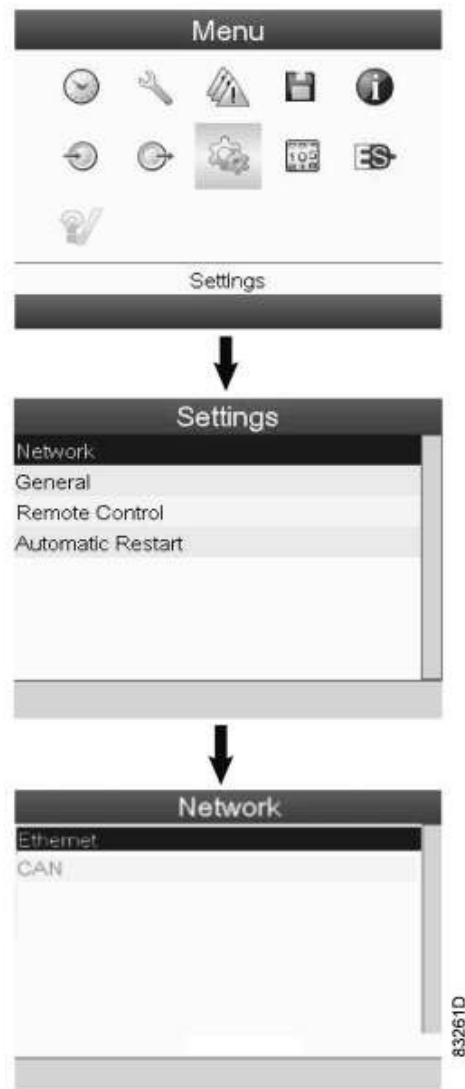

Protections menu

When there is a problem with one of the direct inputs (see previous paragraph), the red warning LED or blue service LED will be lit. When no problem is visible on the pump overview screen (see [Interface icons and menu structure](#)), the Protections submenu must be consulted. The reset button is only applicable for the Delta P warning. For all other faults, the warning disappears when the problem is remedied. The following four situations are important (the fault is indicated in yellow):

1. *Delta P warning*: the real pressure drop over the bacterial filters exceeds the predefined limit (limit can be adjusted, please contact BeaconMedaes if needed). After carrying out the filter replacement successfully (see [Bacterial filter replacement](#)), press *Reset* in the following screen to clear the warning and turn off the blue service LED:

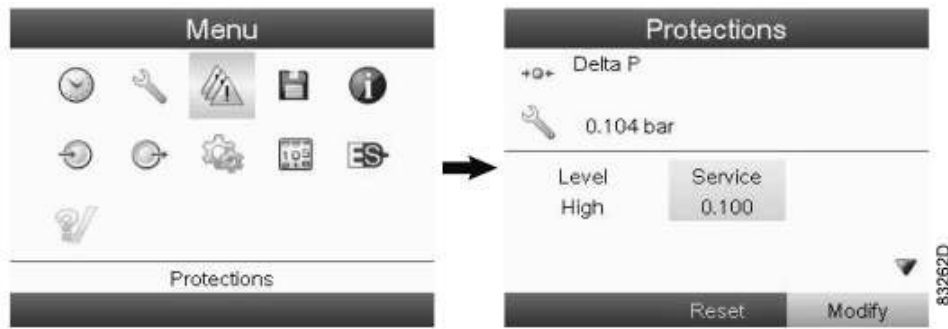

2. *Pump pressure warning:* When the limit is exceeded or no readout is obtained (indicated by stars ***), a problem with the sensor, cable or connections occurred. As long as this fault is active, Delta P can not be calculated. Taking into account the maintenance notes (see [Maintenance notes](#)), check the sensor, the cable and the connections for proper connection and correct wiring according to the service diagram. The fault should be physically remedied (spare parts can be ordered, consult the spare part list), whereby the yellow warning will automatically reset.

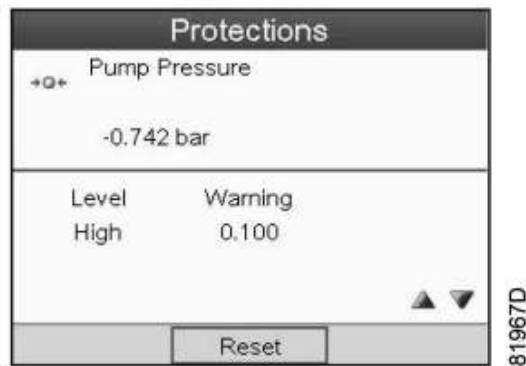

3. *Net pressure warning:* When the limit is exceeded or no readout is obtained (indicated by stars ***), a problem with the sensor, cable or connections occurred. As long as this fault is active, the even wear algorithm uses the Pump pressure readout to control the pumps, if available. Taking into account the maintenance notes (see [Maintenance notes](#)), check the sensor, the cable and the connections for proper connection and correct wiring according to the service diagram. The fault should be physically remedied (spare parts can be ordered, consult the spare part list), whereby the yellow warning LED will automatically reset.



4. *No valid pressure control*: When both the pump pressure sensor and the net pressure sensor are unavailable, the central controller has no pressure feedback and can not control the pumps. Therefore it sends the pump controllers in Forced Local mode until the problem is remedied.



Service menu

Menu icon, Service



Function

- To reset the service plans which are carried out.
- To check when the next service plans are to be carried out.
- To find out which service plans were carried out in the past.
- To modify the programmed service intervals.
- To enable or disable the digital outputs for Plant Faults
- To activate or deactivate a plant fault when the backup pump is integrated.

To access certain service menus and functions, the access key needs to be entered, See section Central controller operation, paragraph *Gaining full access to all menus* how to navigate to the Access Key menu.

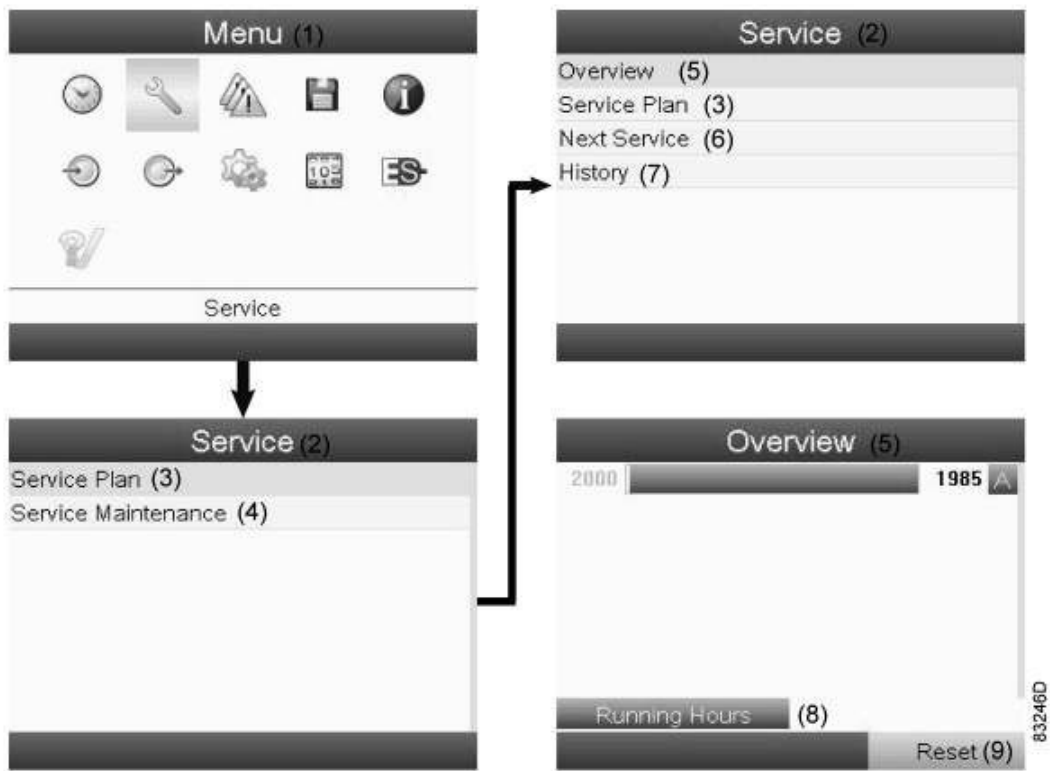

(1)	Menu	(6)	Next service
(2)	Service	(7)	History
(3)	Service plan	(8)	Running hours
(4)	Service maintenance	(9)	Reset
(5)	Overview		

Overview

Example for Service Plan A:

The figure at the left represents the programmed service interval. For Service Plan A, the programmed number of running hours is 2000 hours. The figure at right side of the green status bar is the number of hours to go till the next service intervention. In the example above, the mVAC was just started up, which means it still has 1985 running hours to go before the next service intervention needs to be carried out.

Service Plan

The interval can be changed and adapted to local conditions / requirements

Service Plan (1)		
Level (2)	Running Hours (3)	Real Time (4)
A	2000	
B		
C		
D		
E		
F		
		Modify (5)

83247D

(1)	Service plan
(2)	Level
(3)	Running hours
(4)	Real time hours
(5)	Modify

Next Service Plan

Visualization when the next service intervention needs to be planned.

Next Service (1)		
Level (2)	Running Hours (3)	Actual (4)
		15
A	2000	

83248D

(1)	Next service
(2)	Level
(3)	Running hours
(4)	Actual

In the example above, the A Service level is programmed at 2000 running hours, of which 15 hours have passed.

History

The History screen shows a list of all service actions done in the past, sorted by date. The date at the top is the most recent service action. To see the details of a completed service action (e.g. Service level or Running hours), use the Scroll keys to select the desired action and press the Enter key.



Service maintenance

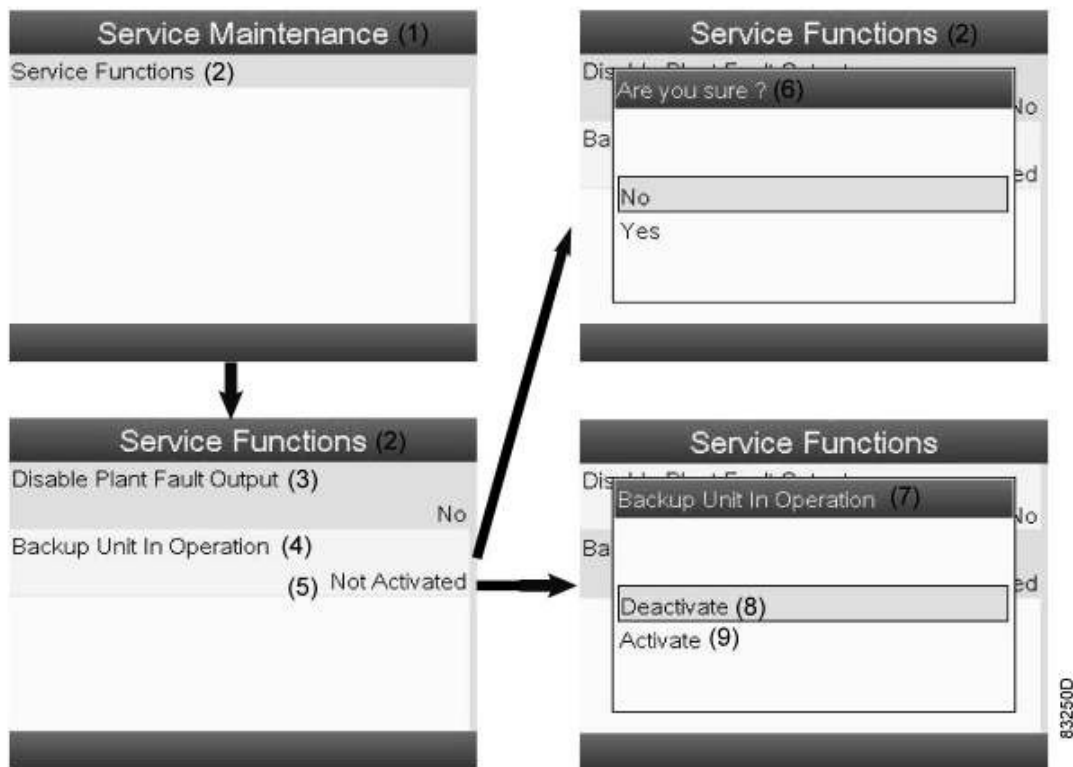

(1)	Service Maintenance	(6)	Are you sure?
(2)	Service Functions	(7)	Backup unit in operation
(3)	Disable plant fault output	(8)	Deactivate
(4)	Backup unit in operation	(9)	Activate
(5)	Not activated		

- Disable Plant Fault Output
 - "No" (default): any Plant Fault will also activate the Digital Output signals.
 - "Yes": the Plant Fault is only visible on the display. The Digital Outputs are not activated anymore. Take utmost care when selecting this option !
- Backup Unit in Operation
 - "Activated" (default): When all pumps including the backup pump are called this will illuminate the red LED and generate a Plant Fault.
 - "Not Activated": No red LED neither Plant Fault is generated when the backup pump is called to assist when high air demand is requested.

6.4 Controller alarms and faults

6.4.1 Controller alarms and faults

Different alarms can be transmitted to the hospital control room by means of digital outputs. The configuration of the potential free contacts is dual. As such there is for instance " Plant Fault " and "2nd Plant Fault". One set of alarms is intended for BMS (Building Management System), the other set is provided with additional resistors and intended to connect to MP125 (Central Alarm System Medipoint 125 from BeaconMedaes). Consult the Service Diagram for the correct configuration.

When an alarm is shown on the central controller, the pump controller and/or the hospital's control room, the necessary actions must be undertaken to investigate and remedy as soon as possible.

There are three different alarm levels. A single alarm or a combination of alarms is possible.

Per alarm, the possible originating faults are described along with their remedies. When trying to remedy problems, always take into account the maintenance notes (see [Maintenance notes](#)).

When no alarm is active, the normal status is shown in green color on the display.

6.4.2 Plant fault

Description

A fault has occurred which potentially leads to the system performing suboptimal, and if left unattended could result in the loss of vacuum.

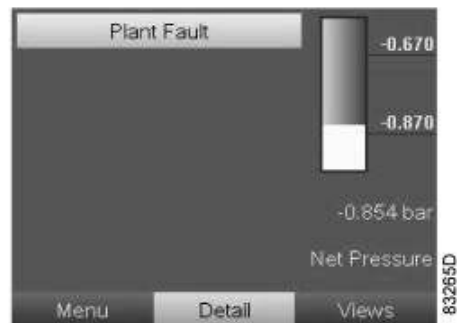

Causes and remedies

First, all pump controllers must be checked for the presence of red LED's being lit (unless if causes 1 or 2 apply, see below). Navigate to the pump overview screen to ensure no warning icons (see [Interface icons and menu structure](#)) are present on any of the pump bars.

When no red LED is lit on one or more pump controllers and no warning icon is present on the pump status bars of the central controller, it is possible there was an unexpectedly high air demand which is larger than the design flow. In such case, all vacuum pumps - including the backup pump - will be called to assist in order to cope with the high air demand. If this situation prevails, the red LED on the central controller is lit. The red LED will be extinguished as soon as vacuum equals the value under *Pressure band 1 High* (default is

-870 mbar(e)) is reached and the backup pump is stopped.

In case it is not desired that a Plant Fault is generated when the backup pump is called at high air demands, there is the option to deactivate this function in the submenu *Service Maintenance*. Put *Backup unit in Operation* to "Not Activated" and no red LED neither Plant Fault will be shown on the central controller.

It is also possible to suppress the relay output for Plant fault on the IO2 module. This can be done by putting *Disable Plant Fault Output* to "Yes" in the submenu *Service Maintenance*. In this case the red LED and Plant Fault is shown on the central controller but there will be no Digital output to BMS (Building Management System) nor MP125. Take care with this option because selecting "Yes" for "Disable Plant Fault Output" will be valid for any Plant Fault which might prevail.

If a red LED is lit on a pump controller, the corresponding problem should occur both on the pump overview screen and on the main display of the pump controller, where it should appear as a blinking icon (see [Interface icons and menustructure](#)):

1. a. *Slave switched to Local:*

Check if the Emergency Forced Local symbol and red LED are present on the pump controller (see [Interface icons and menu structure](#)). If so, a fault may have occurred whereby the system itself did not sustain the vacuum at the required minimum.

Emergency Forced Local will start every pump (that is not in Local Stopped status) automatically based on only one input: the pump's local pressure transducer sensing a pressure less deep than -590 mbar(e). Please contact your customer contact. Once the cause is fixed, and pressure is deeper than -590 mbar(e), the user can only reset the warning by pressing the Escape button, otherwise the pump will run infinitely in this safety mode. If the Local/LAN switch is set to Local and there is no reason for it, please switch it back to LAN control.

This is not a fault as such but constitutes a situation which is sub-optimal (the central controller can't control the pump to ensure even wear or respond to the demand based on pressure difference per unit of time).

b. *No answer:*

Interrelated with the previous fault, sometimes the Emergency Forced Local fault can cause the central controller (ES-VAC) not to find the pump controller. After resetting the Emergency Forced Local as described above, also the following procedure must be carried out (full access needs to be obtained, see [Central controller operation](#)): go to submenu Commands and press Reset.

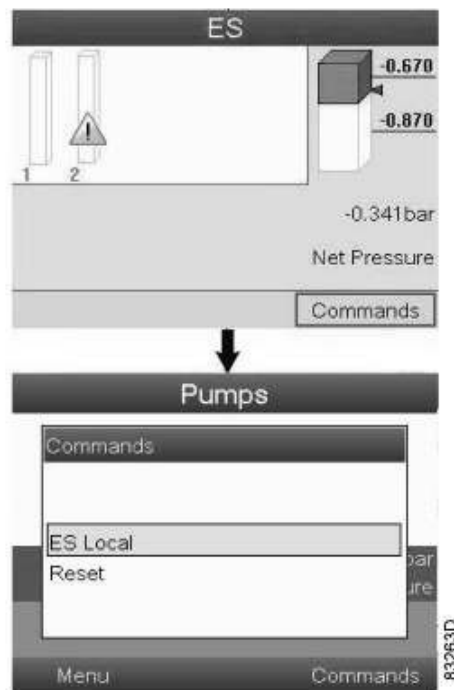

2. **No Communication:** Either the controller has no electrical supply or there is a CAN network error. Taking into account the precautions of chapter [Maintenance notes](#), check that the controller is adequately electrically supplied and fix if necessary. If supply is adequate, check the software CAN settings in both the pump controllers and the central controller (see previous chapters).
Verify that the CAN cables at the backside of the cubicles are correctly connected to the other cubicles. If so, open the cubicle and verify that the CAN cable is correctly connected between the cubicle back plate and the controller. If that is the case, open the CAN connectors and verify that the wires are correctly connected. Contact BeaconMedaes for further investigation.
After fixing the problem, the status should automatically reset. If it doesn't, press "Local" in the commands screen of the central controller and select ES "Off" in the ES menu (see Central controller operation).
Then select On again and press Start in the commands menu. Alternatively, in the CAN menu, press CAN Off and On.
3. **Sensor error:** A problem with the pump's local pressure sensor, cable or connections has occurred or the pressure is out of range (e.g. -1,1 bar). Unless if the pump is in Local Off mode, this error will always start the pump (Emergency Forced Local mode).
Taking into account the precautions of chapter [Maintenance notes](#), check the sensor, the cable and the connections for proper connection and correct wiring according to the service diagram. The fault should be physically remedied (spare parts can be ordered, consult the spare parts list), whereby the alarm will automatically reset. If however the pressure is believed to be out of range (pump runs in Emergency Forced Local mode and plant inlet is closed or no vacuum demand), this error will reset automatically once the pressure is in range again.
4. **Failed To Go On Load (FTGOL):** Two situations can be discerned:
 - When the fault appears when the pump is running, two causes can lead to this fault:
 - The switch, cable or connections lead to a short circuit. Taking into account the precautions of chapter [Maintenance notes](#), check the sensor, the cable and the

connections for proper connection and correct wiring according to the service diagram. The fault should be physically remedied (spare parts can be ordered, consult the spare parts list), whereby the alarm will automatically reset.

- The pump does not succeed in producing a vacuum deeper than -380 mbar(e) (-285 mmHg) within 10 seconds after the pump has been called (asked to run by the controller). This means that the pump is most likely defect. Check that the pump is rotating when called. If not, verify the electrical connections to the pump. If the pump does rotate, flow demand may exceed the plant flow capacity, there may be a leak or a blockage.
- When the fault appears when the pump isn't running, following causes are possible:
 - The switch, cable or connections are broken or loose. Check the sensor, the cable and the connections for proper connection and correct wiring according to the service diagram. The fault should be physically remedied (spare parts can be ordered, consult the spare parts list), whereby the alarm will automatically reset.
 - The non-return valve, installed upstream of the FTGOL (Failed To Go On Load) switch and pump inlet, is locked in open position. This could lead to oil being sucked out from the pump into the piping and must be attended to as soon as possible. Order a non-return valve service kit (consult the spare parts list) and proceed to replacing the non-return valve according to chapter [Non-return valve and inlet screen replacement](#).

	Pump is called	Pump is not called
<<0>> signal received from FTGOL switch	OK	PLANT FAULT ALARM - switch, cable or connections disconnected - non-return valve locked open
<<1>> signal received from FTGOL switch	PLANT FAULT ALARM - switch, cable or connections short-circuited - pump defect	OK

5. Motor tripped: (In case an oil level switch is installed: see cause 6 first.) The motor draws more current (for several seconds) than the value set in the overload protection. This fault will always stop the pump and hence requires immediate attention.

Taking into account the precautions of chapter Maintenance notes, open the corresponding cubicle and verify if the overload setting is according to the recommendation of chapter Fuse values. If so, verify that the supply matches the required voltage +/-10%.

A voltage dip or current surge may have occurred. If the supply is adequate, verify that all connections between cubicle and motor are in order and attached correctly (see service diagram). If so, verify that the pump is maintained as required by chapter Checks and intervals in terms of e.g. oil and filter replacements and inspect the pump for any defaults or blockages. If no cause can be established, please contact BeaconMedaes.

After fixing the problem, press the Reset button on the overload protection inside the cubicle (see picture), close the cubicle and switch On the isolating switch. Press the Escape button (see Interface icons and menu structure to clear the display. Verify that the pump runs without problems for 10 minutes at least (e.g. by testing with JOG function, see Pump controller operation).

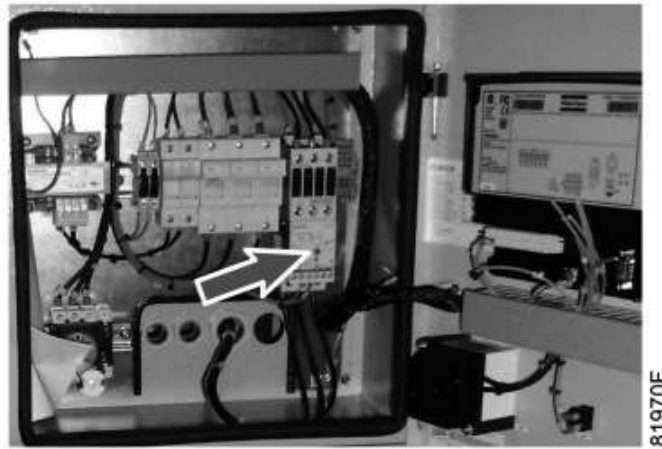

Position of reset button in cubicle.

6. Oil level low (Motor tripped when the oil level switch option is installed): In this case, the red warning LED is lit on the pump controller, additional to the warning sign on the corresponding pump bar graph shown on the central controller and the oil droplet icon on the pump controller. Verify the oil level and replenish if needed (see [Oil, oil filter and oil separator change](#)). If the fault does not disappear automatically, proceed to cause 5.

6.4.3 Plant emergency

Description

The net pressure that is measured upstream of the bacterial filters exceeds -600 mbar(e) (-450 mmHg). Evidently, this situation must be attended to as soon as possible.

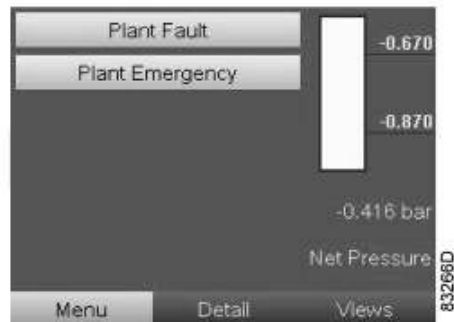

Causes and remedies

The flow demand in vacuum can not be sustained. One of the following causes could lead to this alarm:

1. The plant is not properly sized to meet the flow demand. Conduct a flow test and consult BeaconMedaes.
2. A ball valve is not in the correct position. Check all valve positions (see section [Setting the pneumatic system](#)).
3. One or more pumps are not performing to their full capacity. Check that maintenance is carried out as required according to section [Checks and intervals](#) and that the drawn current on the amp meter (see section

[Interface icons and menu structure](#)) corresponds to the values found in section [Fuse values](#) and as written in the logbook during commissioning.

4. The pressure drop over the bacterial filters exceeds 100 mbar. Carry out maintenance (see section [Bacterial filter replacement](#)).
5. A leak or rupture is present in the piping, hoses, vessels, filters or pumps. Investigate the plant for leaks. When a leak or rupture is found in a section which can be isolated from the main flow, remedy the problem after isolating the section (for spare parts, consult the spare part list).
When the leak or rupture is situated in the main flow pipeline of the plant and cannot be isolated, please contact BeaconMedaes.
6. The piping, hoses or inlets of the pumps are blocked. When a blockage is found in a section which can be isolated from the main flow, remedy the problem after isolating the section (for spare parts, consult the spare part list).
When the blockage is situated in the main flow pipeline of the plant and cannot be isolated, please contact BeaconMedaes.
7. A non-return valve of a pump (situated upstream of the FTGOL switch) is locked in closed position. Pump by pump, verify if there is an impact on the pressure between the pump running and not running (Contact BeaconMedaes). If there is no impact, order a non-return valve service kit (consult the spare parts list) and proceed to replacing the non-return valve according to section [Non-return valve and inlet screen replacement](#).
If there is no impact, order a non-return valve service kit (consult the spare parts list) and proceed to replacing the non-return valve according to section [Non-return valve and inlet screen replacement](#).

6.4.4 Pressure fault

Description

The net pressure that is measured upstream of the bacterial filters exceeds -480 mbar(e) (-360 mmHg). Evidently, this situation requires immediate attention.

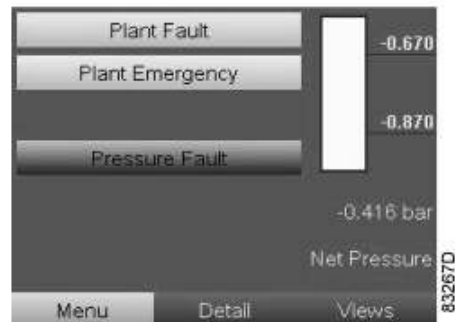

Causes and remedies

This situation is the escalation of the Plant emergency alarm above, and the same causes and remedies apply.

7 Maintenance

7.1 Introduction

Medical vacuum plant installations require periodic routine maintenance to ensure trouble free and reliable operation throughout the life of the plant.

BeaconMedaes offers several types of service contracts, relieving you of all preventive maintenance work. Consult BeaconMedaes.

7.2 Maintenance notes



Additional to the safety precautions mentioned in section [Safety precautions during maintenance or repair](#), special care must be taken when servicing the bacterial filters, pumps, non-return valves, inlet screens, piping, vessels or other components of the mVAC.

1. Proper protective clothing (face mask, eye protection, overall, disposable gloves and apron) must be worn when installing, servicing or handling this equipment.
 -  A service kit with face masks, gloves and overall is available. Consult the Spare Part List for the part number.
2. Danger to health during inspection, cleaning or replacement and danger to the environment: Contaminated filters elements, inlet screens, non-return valves or other components must be disposed of using the hospital procedure for contaminated waste, and drain flasks must be sterilised using hospital equipment and procedures. Any type of particular matter or liquid within a drain flask or inlet screen must be treated as potentially biologically contaminated. Any moisture drained from vessels or other drain points must be treated as biologically contaminated. Prior to transportation, items will be decontaminated as well as possible and the contamination status shall be stated in a [Declaration of contamination](#) form.
3. Prior to vacuum pump maintenance, stop the pump and let it cool down for no more than 20 minutes (in case of oil replacement). Make sure the pump is shut down and locked against inadvertent start up. Prior to opening cubicles, isolate the cubicle from supply by either switching off the isolating switch (pump controllers) or by shutting off the supply at the plant room (central controller).
4. During operation, the surface of the pump may reach temperatures of more than 70° C, risk of burns.
5. Filling oil through the suction (inlet) connection will result in breakage of the vanes and destruction of the vacuum pump. Oil must be filled through the oil fill port only. Risk of injury from hot oil mist with open oil inlet plug, remove only when vacuum pump is stopped. The pump must only be operated with the oil plugs firmly inserted.
6. Degraded oil can choke pipes and coolers. Risk of damage to the vacuum pump due to insufficient lubrication. Risk of explosion due to overheating. If there is suspicion that deposits have gathered inside the vacuum pump, oil must be flushed (contact

BeaconMedaes).

Therefore strictly adhere to the maintenance intervals, checks and procedures as described in this chapter, and strictly adhere to the limitations as described in chapter [Reference conditions and limitations](#).

If a maintenance interval has not been adhered to these and potentially resulting in sludge formation, proceed to procedure [Change from mineral oil to synthetic oil](#).

7. Improper work on the vacuum pump puts the operating safety at risk, approval for operation and warranty will be void. Any dismantling that is beyond of what is described in this manual must be done by specially trained personnel (contact BeaconMedaes).
8. All maintenance work must be carried out by a competent person who must be fully conversant with the procedures and standards required when working on medical vacuum systems. Maintenance personnel must follow the information contained in this manual and must fully appreciate the safety precautions required. Electrical work must only be executed by qualified personnel that knows and observes the following regulations:
 - BS 7671
 - IEC 364 or CENELEC HD 384
 - IEC-report 664
 - National accident prevention regulation.
9. The vacuum pumps emit noise of high intensity. Risk of damage to the hearing. Persons staying in the vicinity of a non noise insulated vacuum pump over extended periods shall wear ear protection.
10. Before disconnecting any piping or opening bypass valves (e.g. over filters), pneumatically isolate the section and slowly in-bleed air to raise the pressure to atmospheric pressure. Do not suddenly open any isolating valve that may cause rapid evacuation of any section that may be at atmospheric pressure. Open valves slowly and allow sufficient time for pressure to stabilise.
11. Check with the hospital if a work permit is required, obtain if necessary.
12. It is essential that only genuine spare parts are used during maintenance. Any damage or malfunction caused by the use of unauthorised parts is not covered by warranty or product liability.
13. The electrical power supply to the central controller must be switched off and isolated prior to carrying out any electrical maintenance work to the central controllers' cubicle.
14. Foresee the correct tools before beginning any maintenance work. During use, it is possible that tools will become contaminated with oil or grease, it is therefore important that tools are cleaned and degreased following any maintenance operation, especially if the same tools are subsequently used with an Oxygen System. When the tools come into contact with possible bacteria contaminated parts (e.g. if the bacterial filters were ruptured), they must be sterilised after completion.
15. Should maintenance personnel come across a doubtful situation such as contamination by mucus or blood, they must stop work and report the situation to the hospitals authorised person. If asked to proceed with maintenance, personnel must follow the guidance of the hospital, and regardless, the following rules must always be observed:
 - a. Biological contamination may appear crystalline or organic.
 - b. Do not be deceived by appearance and treat any foreign material as a possible hazard.
 - c. Do not commence any work on a vacuum system suspected of contamination without authorisation and guidance of the authorised person.
 - d. Do not eat or smoke when working on vacuum systems or components

- suspected as being contaminated.
- e. Do not dispose potentially contaminated material and oil in ordinary waste bins, but according to hospital procedures (e.g. sealed in marked bag and entrusted to hospital authorities for safe disposal). Contact the authorised person if in doubt.
 - f. Do not place contaminated tools or equipment into your tool box.
 - g. Inspect for cuts or abrasions before applying waterproof dressing as necessary to effectively cover all lesions.
 - h. Wear all protective clothing throughout all work stages. Wear the waterproof gloves provided and ensure that they remain intact throughout all work stages. Wear an overall and ensure that it remains fully buttoned.
 - i. Take care not to cut yourself. If a glove is punctured, remove glove and allow wound to bleed freely. The contaminated area should be washed gently under running water and not scrubbed. Inform the authorised person of the incident immediately, and seek medical advice on appropriate action. Report the incident in accordance with company rules.
16. Immediately upon completion of work, remove any contaminated clothing and wash hands (and, if necessary, contaminated tools) in a 2% glutaraldehyde solution (or similar) and rinse under running water.
 17. Any leakage should be attended to immediately. Damaged hoses or flexible joints must be replaced.
 18. Always consult BeaconMedaes if a timer setting has to be changed.
 19. Do not overfill with oil as this may lead to oil loss at high intake pressures.
 20. If the bacterial filter drain is often filled with fluid, it could indicate contamination of the pipeline and must be investigated. The bacterial filter must be replaced after the source of contamination has been identified and removed, and after the filter pipeline has been dried out.
 21. A logbook will be kept with all maintenance activities and their date and running hours.

7.3 Checks and intervals

Regular checks

When no alarm system is in place that warns personnel directly, check the controller displays daily for readings and messages.

When problems with the power supply have occurred, it is advised to check the displays immediately. Normally, the display shows the plant / pumps inlet pressure and the status of the plant / pumps.

Remedy the problem if alarm LED's are lit or alarms are present on the displays, see section [Interface, icons and menu structure](#).

The service (blue) LED's will be lit or the display will show a service message if a service level for a monitored component has been exceeded. Carry out the service actions of the indicated plans or replace the component and reset the relevant item, see following sections.

Maintenance and inspection of vacuum vessels

The applicable national regulations must be observed. The corrosion allowance is 1 mm. After internal checks, the seals of the inspection opening(s) must be replaced.

No measures which will in any way modify the structure (e.g. welding, heat treatment, etc.) must be performed on the pressure vessel.

Intervals (see also the service plan on the controller)



The following intervals are a guideline for nominal working conditions. BeaconMedaes may overrule the maintenance schedule, especially the service intervals, depending on the environmental and working conditions of the plant.

Weekly

- Check the oil level of each pump. After stopping, the oil level should be around the middle of the sight glass.
The oil colour should be light, either transparent, a little foamy or a little tarnished. A milky discoloration that does not vanish after sedation of the oil indicates contamination with foreign material.
 - If the level is too low, add oil. See section [Oil, oil filter and oil separator change](#).
 - If the oil is abnormally discoloured, replace the oil, oil filter and the oil separator. See section [Oil, oil filter and oil separator change](#). Oil that is either contaminated with foreign material or burnt, oxidated or carbonised must be changed. In such case, replace oil filter, exhaust oil separators, cooler, and any other component that is suspected or inspected/verified to contain oil sludge to prevent oil sludge from blocking the oil channels.
If the discoloration happens sooner than expected based on the intervals described below, it is advised to check if the ambient temperature regularly exceeds 30 °C. If this is the case, it is advised to use synthetic oil instead of mineral oil. Change-over between oil types must be carried out strictly according to the procedure described in paragraph [Change from mineral oil to synthetic oil](#).
Ambient temperatures consistently over 40 °C are not covered by the operating conditions and will necessitate very frequent maintenance. Synthetic oil is mandatory and it is advised to install sufficient cooling.
- An oil analysis can additionally be carried out every 500 running hours to establish the change interval based on the specific operating conditions.
- Visually inspect all vacuum pumps for dust, security and any sign of oil leakage. Clean off dust and rectify all defects as necessary taking into account the warnings in paragraph [Maintenance notes](#).
- Check the bacterial filter drain flask and the pump exhaust drain flask to ensure no liquid is present. If any liquid is present, proceed to paragraph [Drain flask change](#).
- Check the bacterial filter breakdown indicator. The pressure drop across a bacterial filter depends upon the flow passing through the filter. Therefore this check should be carried out with at least one vacuum pump running. If the differential pressure indicator is in the red zone, replace the bacterial filter element in accordance with section [Bacterial filter replacement](#). This is also the case when the central controller warns for a pressure difference over 100 mbar. (see [Central controller operation](#))

Monthly

Check the function of the oil separator by inspecting the drawn current on the amp meter. It should be in the usual range and as written down in the logbook during commissioning. If

there is a substantial decrease or increase in the nominal drawn current, the oil separator is clogged or ruptured and must be replaced with new ones. Oil in the exhaust drain flask can also be indicative of a saturated or ruptured oil separator. See section [Oil, oil filter and oil separator change](#) to replace the oil separator.

6 - monthly or every 1000 running hours(*)

Every 6 months or 1000 hours, oil change and oil filter change is required if standard mineral oil is being used. See paragraph [Oil, oil filter and oil separator change](#). Order the small maintenance kit that corresponds to your pump type (consult the spare parts list). Order also the right amount of 5 litre oil cans to cover the total amount of oil needed for your pumps, see [Design data](#).

- Clean the fan cowlings, fan wheels, ventilation protection screen and cooling fins.
- Inspect the flexible hoses and pipes for damaged braiding, loose connections and corrosion. Rectify or replace as necessary.
- Drain the vessels. Vessel per vessel, close the air isolation valve and dismount the plug underneath the drain valve, open the drain valve and allow any liquid to drain into a receptacle. Dispose according to section [Maintenance notes](#), close the drain valve and open the vessel isolation valve.

Yearly or every 2000 running hours(*) - Service plan A

Additional to the previously described maintenance procedures, each pump now requires an oil change, oil filter change and oil separator change. See paragraph [Oil, oil filter and oil separator change](#). Order the maintenance kit that corresponds to your pump type. Order also the right amount of 5 litre oil cans to cover the total amount of oil needed for your pumps, see [Design data](#).

At least once a year, the bacterial inlet filters need to be replaced. Proceed to chapter [Maintenance notes](#). Order the kit that corresponds to your plant type.

2 - yearly or every 4000 running hours(*)

Additional to the previously described maintenance procedures, the pump inlet system requires replacement, see paragraph [Non-return valve and inlet screen replacement](#).

5- yearly or every 10000 running hours(*)

At this point, each pump requires a major check and all flexible hoses must be replaced. Please contact BeaconMedaes.

(*): whichever comes first.

7.4 Oil, oil filter and oil separator change

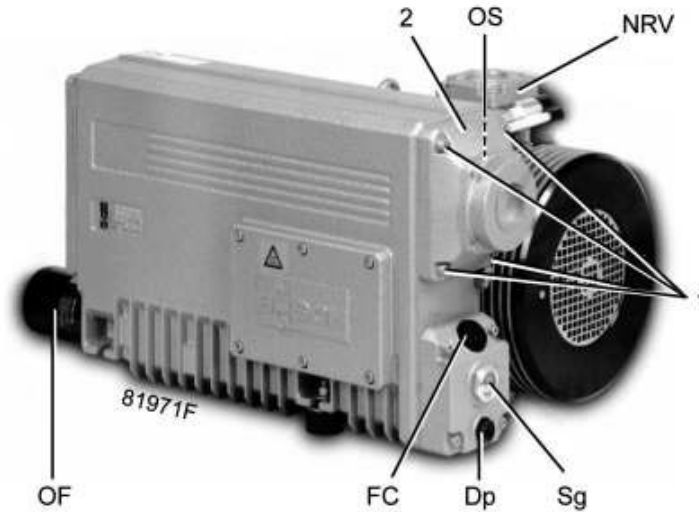

View of one pump.

	Description		Description
1	Cover bolts (4x)	NRV	Non return valve
2	Discharge cover	OF	Oil filter
Dp	Drain plug	OS	Oil separator
FC	Oil fill plug	Sg	Oil sight glass



Please respect the maintenance notes. See [Maintenance notes](#).



Important:

The sight glass might be discolored because of the oil and hence the actual level might be difficult to see. Therefore, upon oil change, between oil drain and oil fill, clean the inside of the oil glass if this is the case.

The procedure for oil and oil filter change is as follows:

1. Ensure that this procedure is carried out one pump at a time, as to ensure that the other pumps can still maintain the vacuum required. Check that the other pumps are fully operational.
2. If you do not wish to transmit alarms to the hospital staff, go to chapter [Isolating a pump controller](#) in section [Central controller operation](#).
3. Close the ball valve upstream the pump which is due to service. Switch off the pumps' isolating switch on the corresponding cubicle, ensure that the power LED on its' controller is unlit and let the pump cool off for no more than 20 minutes. Make sure that the pump is vented to atmospheric pressure.
4. Put a drain tray underneath the oil drain port, remove the oil drain plug (Dp) and drain the oil.
5. Replace the O-ring in the drain plug and firmly re-insert the drain plug.
6. Remove the oil filter (OF).

7. Apply a drop of fresh oil on the seal ring of the new oil filter, mount it and tighten by hand.
8. Remove the oil fill plug (FC) and fill in oil until the level in the sight glass (Sg) is close to the MAX indication.
9. Replace the O-ring in the fill plug and re-insert the fill plug firmly.
10. Open the ball valve upstream the pump, switch the isolating switch back to On and integrate the pump in the software.
11. Observe the pump during a few cycles to make sure it is running normally.
12. Reset the Service counter in the pump controller (d.4), see chapter Resetting service running hours in section [Pump controller operation](#).

The procedure for changing the oil separator (OS) is as follows:

1. Ensure that this procedure is carried out one pump at a time, as to ensure that the other pumps can still maintain the vacuum required. Check that the other pumps are fully operational.
2. If you do not wish to transmit alarms to the hospital staff, go to chapter [Isolating a pump controller](#) in section [Central controller operation](#).
3. Close the ball valve upstream the pump, switch off the pumps' isolating switch on the corresponding cubicle, ensure that the power LED on its' controller is unlit and let the pump cool off for no more than 20 minutes. Make sure that the pump is vented to atmospheric pressure.
4. Unscrew the 4 bolts (1) in the discharge cover (2). Bend the flexible hose of the discharge line slightly so that the discharge cover is removed from the pump. If required, loosen the coupling ring at the copper stub connection, effectively disconnecting the flexible hose from the exhaust pipe.
5. Release and remove the spring elements by unscrewing the attached screws.
6. Remove the oil separator element(s), O-ring and seal ring.
7. Insert the new oil separator, O-ring and seal ring. Be sure to fit the oil separator correctly as indicated by the arrow.
8. Mount the spring elements and apply a tension to them by means of the tension screws.
9. Bring the exhaust flexible back into place and mount the discharge cover (2) with the screws (1). Remount the coupling ring, re-attaching the flexible hose to the exhaust pipe, if applicable.
10. Open the ball valve, switch the isolating switch back to On and integrate the pump in the software.
11. Observe the pump during a few cycles to make sure it is running normally.
12. Reset the service counter in the central controller (ES-VAC), see chapter Service in section [Central controller operation](#).

7.5 Oil specifications

It is strongly recommended to use only the genuine recommended lubricants.

They are the result of years of field experience and research. See section [Checks and intervals](#) for the advised replacement intervals and consult your spare parts list for part number information.



Never mix lubricants of different brands or types as they may not be compatible and the oil mix will have inferior properties.
Always drain the pump as good as possible. Used oil left in the pump shortens the lifetime of the new oil.

Petroleum based vacuum pump oil

Petroleum based vacuum pump oil is a lubricant, specially developed for use in rotary vane vacuum pumps using standard ISO-100 mineral based oil. Its specific composition keeps the pumps in excellent condition. It can be used for pumps operating at ambient temperatures between 0 °C (32 °F) and 30°C (86 °F). If the pump is regularly operating in ambient temperatures between 30°C (86 °F) and 40 °C (104 °F), it is recommended to use PAO-based vacuum pump oil.

PAO-based vacuum pump oil

PAO-based vacuum pump oil is a high quality synthetic lubricant for rotary vane vacuum pumps operating at ambient temperatures between 0 °C (32 °F) and 40 °C (104 °F). Because of its excellent oxidation stability, PAO-based vacuum pump oil is recommended for pumps operating at ambient temperatures between 30 °C (86 °F) and 40 °C (104 °F).

7.6 Bacterial filter replacement

	<p>Always respect the maintenance notes. See Maintenance notes. Filter elements cannot be cleaned or reused. Dispose of in accordance with hospital procedures for contaminated waste. Do not overtighten the filter element as distortion of the O-ring seals may occur and prevent an effective seal.</p>
---	---

The procedure to replace the bacterial filter is as follows:

1. For mVAC types with the filters housed in a (separate) frame, it is allowed to dismount the support beams at the side to allow easier access to the filters.
2. Set the filter(s) that is (are) not going to be changed online by slowly, fully opening the valves before and after the filter(s).
3. Isolate the filter(s) that is (are) going to be changed by fully closing the valves before and after the filter(s).
4. Isolate the drain flask (Df) in use by closing the isolating valve. If any liquid is present, follow the instructions as given in [Maintenance notes](#) and notify the Authorised Person (MGPS) immediately. Otherwise, remove the drain flask.
5. Remove the filter housing. Unscrew/unclamp the filter housing and remove. To unscrew the filter housing, it may be convenient to use a special strap tool.
6. Remove the filter element (Bfe) and dispose it according to hospital procedures for contaminated waste.
7. Fit the new filter element and secure it with the retaining nut (if applicable). Tighten by hand.
8. Refit the filter bowl housing, screw the drain flask back on and open the drain valve.

9. Reset the Delta P warning in the ES-VAC if necessary (see paragraph Service Menu in section [Central controller operation](#)).

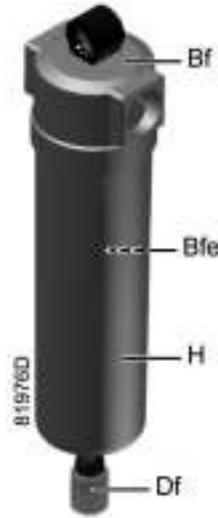

Bacterial filter with drain flask

Bf	Filter head	Df	Drain flask
Bfe	Bacterial filter element	H	Filter housing

7.7 Drain flask change

	<p>Please respect the maintenance notes. See Maintenance notes. If any liquid is present in the drain flask, inform the Authorised Person (MGPS) immediately; otherwise, remove the drainage flask and replace it according below described procedure.</p>
--	--

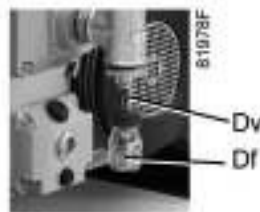

Drain flask on a pump

The procedure to replace a drain flask (Df) is as follows:

1. Close the corresponding drain valve (Dv).
2. Unscrew the drain flask (Df) (treat as contaminated waste) and mount the new one. A drain flask is suitable for sterilisation.
3. Open the drain valve (Dv).

7.8 Non-return valve and inlet screen replacement

	<p>Always respect the maintenance notes. See Maintenance notes.</p>
--	---

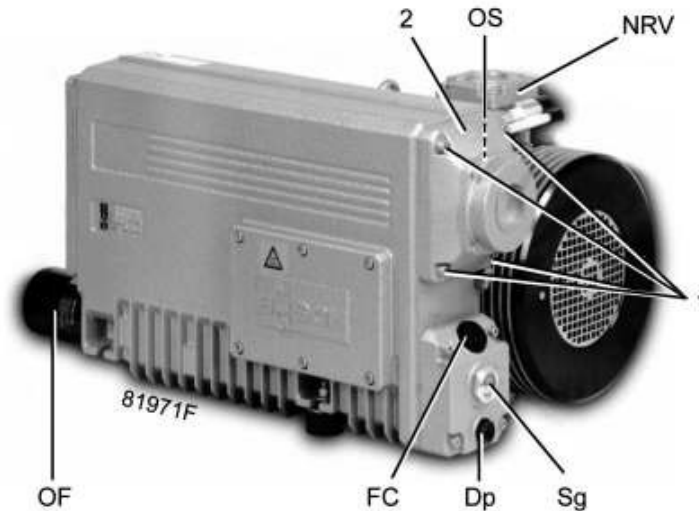

The procedure to replace the non-return valve (NRV) and the inlet screen is as follows:

1. Ensure that this procedure is carried out on one pump at a time, as to ensure that the other pumps can still maintain the vacuum required. Check that the other pumps are fully operational.
2. If you do not wish to transmit alarms to the hospital staff, follow the procedures explained in section [Central controller operation](#).
3. Switch off the pumps' isolating switch on the corresponding cubicle, ensure that the power LED on its controller is off and let the pump cool down. Make sure that the pump is vented to atmospheric pressure.
4. Close the valve at the inlet side of the corresponding pump.
5. Dismount the 4 screws from the inlet chamber and bend the flexible hose slightly so that the inlet cover is removed from the pump.
6. From the top section behind the inlet cover, remove the inlet screen and the O-ring.
7. From the lower section, closest to the vane chamber, remove the O-rings, the non-return valve and the spring.
8. In the same order, insert the new non-return valve components, inlet screen and O-rings. The cylindrical housing is reused. By pressing gently up and down, test that the new non-return valve is fitted correctly and see to it that all O-rings are positioned correctly.
9. Remount the 4 screws tightly to fix the inlet chamber to the pump.
10. Reopen the inlet valve and switch the pumps' isolating switch to On.
11. Listen closely as the pump runs to ensure that no leaks have been created. Observe the controllers' display of the pump as it starts up and shuts down to ensure that the non-return valve is working correctly. See section [Plant fault](#), FTGOL switch.
12. Observe the pump during a few cycles to make sure it is running normally.

7.9 Change from mineral oil to synthetic oil

To prevent the synthetic oil dissolving residual oil sludge (and hence blocking channels), the following procedure must be strictly followed:

1. Drain the used oil completely.
2. Clean the carter housing inside manually as good as possible (e.g. with clean dry cloth).
3. Change the oil filter, but leave the existing exhaust oil separators in place.
4. Fill the pump with new synthetic oil in the correct amount.
5. Run the pump for about 2 hours (jog mode), then stop it. Drain the oil, clean inside as before

- and change the oil filter.
6. Refill with new synthetic oil and change the exhaust oil separators. Repeat this procedure until the oil remains clean (sight glass).

7.10 Vacuum pump replacement



Please respect the maintenance notes. See [Maintenance notes](#).

A special lifting device which facilitates this job and allows to carry out this intervention in a safe way is available. Please contact your representative in case of interest or need for assistance.

The procedure to replace a single vacuum pump while the plant installation remains operative is as follows:

1. Ensure that this procedure is carried out one pump at a time, as to ensure that the other pumps can still maintain the vacuum required. Check that the other pumps are fully operational.
2. If you do not wish to transmit alarms to the hospital staff, go to Central controller operation.
3. Switch off the pumps' isolating switch on the corresponding cubicle, ensure that the power LED on its' controller is unlit and let the pump cool off for no more than 20 minutes. Make sure that the pump is vented to atmospheric pressure.
4. Close the valve at the inlet side of the corresponding pump.
5. Dismount the flexible hoses from the inlet and outlet of the pump and unscrew the bolts at the underside of the plate on which the pump is fixed.
6. Open the motor electrical box and disconnect the wires.
7. Lift the pump slightly upward and outward towards the exhaust side of the plant. It might be needed to dismount cable guiders or support beams, do this carefully and re-attach them after removing the pump.
8. The new or refurbished pump can then be refit in the same manner: gently lift the pump into place, mount connection bolts, inlets and outlets and connect the electric wires.
9. Make sure to install and commission the pump according to sections [Electrical functional check](#).
10. Reopen the inlet valve and switch the pumps' isolating switch to On.
11. Observe the pump during a few cycles to make sure it is running normally.

7.11 Dismantling and disposal



Please respect the maintenance notes. See [Maintenance notes](#).

The procedure to dismantle and dispose of the vacuum plant is as follows:

1. Switch off all isolating switches and the main power supply switches.
2. Clean drains and filters as described in sections [Bacterial filter replacement](#) and [Drain flask change](#).
3. Close the inlet connection point valve and open one of the drain valves without drain flask slowly to bring the pressure inside the pipes to atmospheric pressure.
4. Disconnect all electric cables and dismount the cubicles.
5. Drain all oil from the vacuum pumps and remove the oil filters.
6. Separate all materials and components to be treated as special waste from the pump.
7. Dispose of the oil and contaminated items (piping, filters, .) in compliance with the

- applicable regulations.
8. Dispose of electric components according to the applicable regulations.
 9. Dispose of any other uncontaminated material as scrap metal.

7.12 Service kits

A wide range of service kits is available. Service kits comprise all parts required for servicing components and offer the benefits of genuine parts while keeping the maintenance budget low. Consult the spare parts list for part numbers. For parts which are not listed (e.g. pump parts not included in the service kits), please contact your supplier.

7 Pictographs

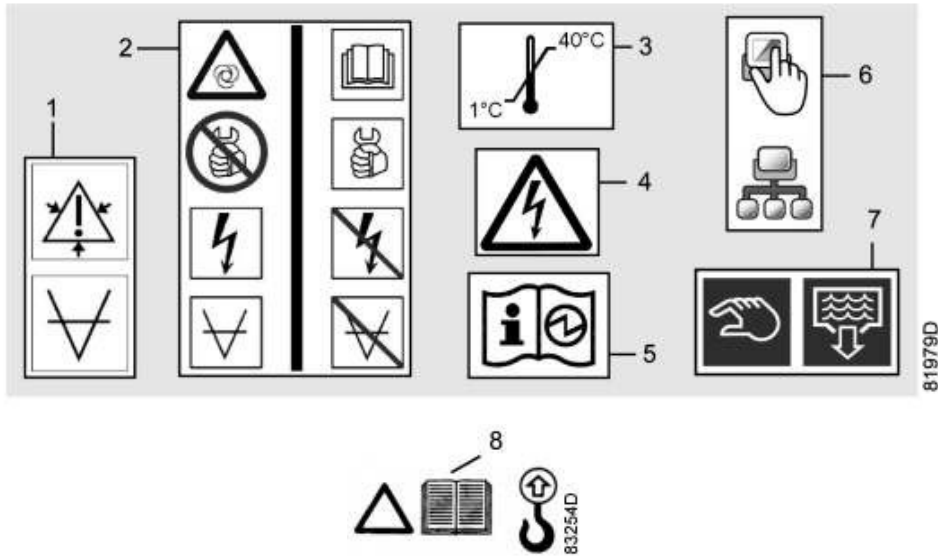

Reference	Description
1	Pressurized (vacuum), open slowly.
2	Warning: automatic operation. Read the manual. Service only allowed on components not under voltage or vacuum.
3	Ambient temperature limits.
4	Warning electricity (isolate before opening).
5	Read the manual, manual provided electronic.
6	Local control/LAN control (see section Pump controller operation).
7	Manual drain.
8	Read instructions in the manual how to lift the unit

9 Problem solving

9.1 Introduction and warnings

	<p>For location and names of components, refer to the previous chapters. Item numbers of spare parts needed to remedy problems can be found in the spare part list.</p> <p>If not, please contact BeaconMedaes.</p> <p>When a remedy corresponds to a procedure specifically explained in chapter Maintenance, consult the relevant paragraph and follow the procedure.</p>
---	---

All precautions of chapter [Safety precautions during maintenance or repair](#) and [Maintenance notes](#) apply when attempting to remedy faults.

9.2 Faults and remedies

Drive

Component	Condition	Potential cause of the fault	Remedy
Motor	Motor does not rotate	Defect of motor Impeller or motor mechanically blocked	Check motor connections Check for obstructions in the housing
	Motor can rotate, but stops during startup process	Protection active Voltage interruption Voltage too low Load too high Supply phase missing Earth fault Short circuit	Check motor connections Check software Check supply
	Motor rotates in reverse direction (after test)	Motor phases connected in wrong order	Switch 2 phases
	Motor runs too slow	Load too high Supply phase interrupted Wear Back pressure rise (oil separator saturation)	Check motor connections Replace oil separator Replace defective components (contact BeaconMedaes)
	Motor runs too fast	Wrong frequency	Check frequency of supply voltage and frequency of mVAC
	Motor runs irregularly	Bearing defect Winding defect Wire loose	Check motor connections Replace worn parts (contact BeaconMedaes)
	Motor speed decreases over time	Back pressure rise (oil separator saturation)	Replace oil separator Replace defective components (contact BeaconMedaes)

	Motor draws too high current or even trips on overload.	Clogged or saturated oil separator filters Too high back pressure in the outlet piping	Replace oil separator and investigate reason for clogging. Check size of outlet piping.
--	---	---	---

Component	Condition	Potential cause of the fault	Remedy
Encasing	Holes exposing moving parts	Supplier fault Hole exposed during operation/maintenance	Cover hole (contact BeaconMedaes)

Pump

Component	Condition	Potential cause of the fault	Remedy
Pump	Pump does not rotate	Rotor blocked Check for obstructions in the Coupling defect housing	
	Pump vane(s) broken	Wear/damage Start-up with too much oil Wrong oil type Dirt intrusion in pump	Check sight glass for too much oil Check inlet screen Replace defective components (contact BeaconMedaes)
	Pump runs irregularly	Wear/damage Too high pressure ratio Debris in the pump inlet	Replace oil separator Replace defective components (contact BeaconMedaes) Check inlet screen
	Pump starts in reverse rotation	Motor phases connected in wrong order	Switch 2 phases
	Pump starts in reverse rotation when there is no voltage on motor connections	Back pressure at the outlet Non-return valve defective	Check non-return valve Check back-pressure (to be < 60 mbar(e)) Replace worn parts
	Pump gives insufficient or varying air flow	Wear/damage Debris in the inlet pipe Inlet filter clogged Debris in the inlet of the pump	Cleaning of piping Replace filters Replace defective components (contact BeaconMedaes)
	Pumps' temperature limit exceeded	Wear/damage Debris in the inlet pipe Inlet filter clogged Debris in the inlet of the pump (inlet filter ruptured) Too much back pressure Too high ambient temp Oil level too low Wrong oil used	Check ambient temperature (to be < 40 °C) Cleaning of piping Check back-pressure (to be < 60 mbar(e)) Check current on A-meter Replace defective components (contact BeaconMedaes) Check oil sight glass Replace oil

Component	Condition	Potential cause of the fault	Remedy
Oil	Pump has no oil	Forgot to fill Oil depleted through inlet (non- return valve failed) Oil depleted through outlet (oil separator ruptured/saturated) Leak in oil circuit	Check oil level in sightglass Check oil circuit Fill oil Consider oil level switch option
	Oil level too low	Insufficient quantity filled Oil depleted through inlet (non- return valve failed) Oil depleted through outlet Leak in oil circuit	Check oil level in sightglass Check oil circuit Add oil Consider oil level switch option
	Oil level too high	Overfilling Sucking in oil from other pump due to defective non-return valve	Check sight glass Replace non-return valves, starting by checking pump with least oil
Non-return valve	Non-return valve does not close (partial/complete closing)	Mechanical defect	Check non-return valve Replace worn parts
	Non-return valve does not open (partial/complete opening)	Mechanical defect	Check non-return valve Replace worn parts
Screen (inlet filter mesh)	Inlet screen does not block particles	Screen ruptured / badly assembled Bacteria filters ruptured Components coming loose from mVAC piping system	Check screen Check inlet filters Replace worn parts (contact BeaconMedaes Check/clean piping
	Inlet screen blocks flow (partial/ complete blocking)	Clogged Bacteria filters ruptured Components coming loose from mVAC piping system	Check screen Check inlet filters Replace worn parts Check/clean piping

Vacuum inlet system

Component	Condition	Potential cause of the fault	Remedy
Bacterial filter element	Filter does not filter or filters insufficiently	Wrong assembly/service of filter element Filter ruptured	Check filter Replace filter
	No or little passage of air through filter	Filter element contaminated Filter blocked	Check filter Replace filter

Component	Condition	Potential cause of the fault	Remedy
Connection pipes/hoses from inlet pipe to pumps	Transport of air obstructed or constricted in the piping/hoses	External/loose internal particles/oil	Check/clean piping
	Rupture in the piping/hoses	Vibrations Corrosion Ageing Shorter bend than specified Contact of hose	Check bending radius/contact of hoses Replace defective parts
	Leakage in the piping/hoses	Bad assembly of connections	Check connections Replace defective parts
	Oil is visible in a hose	A non-return valve is broken	Check non-return valves, starting by pump with least oil Replace non-return valve if non functional

Outlet system

Component	Condition	Potential cause of the fault	Remedy
Connection pipes/hoses from outlet pumps to piping network	Transport of air obstructed or constricted in the exhaust piping/hoses	External/loose internal particles / oil	Check/clean piping Empty/replace drain flask
	Rupture in the exhaust piping/hoses	Vibrations Ageing Shorter bend than specified Contact of hose	Check bending radius / contact of hoses Replace worn parts
	Leakage in the exhaust piping/hoses	Bad assembly of connections	Check connections Replace worn parts

Auxiliaries

Component	Condition	Potential cause of the fault	Remedy
Drain flask (filters)	Drain flask broken	Construction fault Transport damage Installation damage Maintenance damage	Check for cracks/leaks after handling Replace defective parts
	Drain flask full	Regular check not performed	Regular checks Empty/replace drain flask
Vessel	Vessel buffers less than designed	(Partial) obstruction Condensate/oil buildup in vessel	Regular check of vessel drain flask Empty/replace drain flask

	Oil is present in the vessel	A non-return valve is broken	Check non-return valves, starting by pump with least oil Replace the defective valve
--	------------------------------	------------------------------	---

Frame

Component	Condition	Potential cause of the fault	Remedy
Frame	Frame gives insufficient support	Overload and/or deformation of frame because of mechanical causes Loose bolts Incorrect positioning	Contact BeaconMedaes

Measurement system

Component	Condition	Potential cause of the fault	Remedy
Line pressure sensor	Line pressure sensor: malfunctioning	Mechanical defect	Replace defective components (contact BeaconMedaes)
	Line pressure sensor: no measurement (error signal)	Electrical connection of sensor (internal or external) interrupted Mechanical damage (too high mounting torque) Connection plugs not connected Crack because of vibration or incorrect mounting Sensor internally defect No supply voltage	Check electrical connections Check sensor
	Line pressure sensor: measurement too low (e.g. measures -620 instead of true -600 mbar)	Condense on connection plugs Faulty supply signal Clogging or contamination Sensor internally defect Deviation due to ageing Deviation due to incorrect production	Check sensor Replace defective components (contact BeaconMedaes)
	Line pressure sensor: measurement too high (e.g. measures -580 instead of true -600 mbar)	Condense on connection plugs Faulty supply signal Clogging or contamination Sensor internally defect Deviation due to ageing Deviation due to incorrect production	If difference with true pressure surpasses 40 mbar: Check sensor Replace defective components (contact BeaconMedaes)

Component	Condition	Potential cause of the fault	Remedy
Overall pump pressure	Overall pump pressure sensor (after filters) :	Mechanical defect	Replace defective components (contact BeaconMedaes)

sensor	malfunctioning		
	Overall pump pressure sensor (after filters) : no measurement (zero- signal)	Electrical connection of sensor (internal or external) interrupted Mechanical damage (too high mounting torque) Connection plugs not connected Crack because of vibration or incorrect mounting Sensor internally defect No supply voltage	Check electrical connections Check sensor
	Overall pump pressure sensor (after filters) : measurement too low (e.g. measures -630 instead of -600 mbar)	Condense on connection plugs Faulty supply signal Clogging or contamination Sensor internally defect Deviation due to aging Deviation due to incorrect production	If difference with true pressure surpasses 40 mbar: Check sensor Replace defective components (contact BeaconMedaes)
	Overall pump pressure sensor (after filters): measurement too high (e.g. measures -570 instead of -600 mbar)	Condense on connection plugs Faulty supply signal Clogging or contamination Sensor internally defect Deviation due to ageing Deviation due to incorrect production	Allowed situation within limits. If difference with true pressure surpasses 40 mbar: Check sensor Replace defective components (contact BeaconMedaes)

Component	Condition	Potential cause of the fault	Remedy
Single Pump Pressure sensor	Pressure sensor per pump: malfunctioning	Mechanical defect	Replace defective components (contact BeaconMedaes)
	Pressure sensor per pump: no measurement (zero- signal)	Electrical connection of sensor (internal or external) interrupted Mechanical damage (too high mounting torque) Connection plugs not connected Crack because of vibration or incorrect mounting Sensor internally defect No supply voltage	Check electrical connections Check sensor
	Pressure sensor per pump: measurement too low	Condense on connection plugs Faulty supply signal Clogging or contamination Sensor internally defect Deviation due to aging Deviation due to incorrect production	If difference with true pressure surpasses 40 mbar: Check sensor Replace defective components (contact BeaconMedaes)
	Pressure sensor per pump: measurement too high	Condense on connection plugs Faulty supply signal Clogging or contamination Sensor internally defect Deviation due to ageing Deviation due to incorrect production	Allowed situation within limits. If difference with true pressure surpasses 40 mbar: Check sensor Replace defective components (contact BeaconMedaes)
Single Pump Pressure switch (FTGOL)	FTGOL switch per pump: gives status "No vacuum" when vacuum is demanded from pump	Pump defect Switch defect / wrong setting Doesn't open Wires short-circuited	Check pump (e.g. JOG function) Check switch / setting Check electrical cables/ connections Replace defective components (contact BeaconMedaes)
	FTGOL switch per pump: gives status "Vacuum" when vacuum isn't demanded from pump	Non-return valve defect: doesn't close Wrong switch setting: doesn't close Wire/connection broken Vaness block off back-flow	Check the non return valve Check switch / setting Check electrical cables/ connections Replace defective components (contact BeaconMedaes)

Control and Regulation System

Component	Condition	Potential cause of the fault	Remedy
Central control module (ES-VAC)	Central controller: doesn't read in pressures	Software fault	Re-download software
	Central controller: doesn't read in (correct) Slave states	Software fault	Re-download software
	Central controller: software too slow	Software fault	Re-download software
	Central controller: doesn't produce run queue	Software fault	Re-download software
	Central controller: doesn't operate		
	Central controller: gives out "Run" command too slowly	Software fault	Re-download software
	Central controller: gives out "Not Run" command too slowly	Software fault Connection fault between ES-VAC and hospital control room display	Re-download software Check connection between ES-VAC and hospital control room display
	Central controller: doesn't issue alarm(s) while it should	Software fault	Re-download software
	Central controller: doesn't issue service warning(s) while it should	Software fault	Re-download software
Pump module (unit controller)	Pump controller: doesn't read in pressure	Software fault	Re-download software
	Pump controller: doesn't operate	Software fault Communication fault to motor (/cable disconnected)	Re-download software Check cable connections

Auxiliary Electrical components

Component	Condition	Potential cause of the fault	Remedy
Cubicle	Cubicle: does not comply with IP54	Insufficient sealing Holes in cubicle Cable glands not closed Locks defect Cubicle ruptured mechanically	<ul style="list-style-type: none"> • After handling, check sealing/ cracks/holes • Replace defective components

	Cubicle: insufficient protection	Door open Locks defect Cubicle under voltage <<Finger proof>> protections removed	After handling, check sealing/ cracks/holes Replace defective components (contact BeaconMedaes
Power supply cable of drive motor	No voltage to motor Inadequate current allowed through	Supply problem Broken cables High contact resistance Power cable mechanically damaged	Check Elektronikon module (/LED)/A-meter Check cables/connections Replace defective components (contact BeaconMedaes Restore power
	Insufficient or no insulation	Insulation is damaged	Check cables/connections Replace defective components (contact BeaconMedaes
Fuses	Fuse opens too late or not at all	(Re)placed by wrong size	Check fuse specification/state Replace defective components (contact BeaconMedaes
	Fuse opens too soon	(Re)placed by wrong size	Check fuse specification/state Replace defective components (contact BeaconMedaes
Transformer	Gives no voltage Gives the wrong voltage to the line circuit	Faulty transformer Loose connections No main power voltage Wrong connections Wrong replacement	Check Elektronikon module (/LED)/A-meter Check cables/connections Replace defective components (contact BeaconMedaes
	Incomplete insulation between primary and secondary windings Gives the primary voltage to the line circuit	Faulty insulation of the transformer	Check cables/connections Replace defective components (contact BeaconMedaes

Component	Condition	Potential cause of the fault	Remedy
Electrical connections	Electrical connection broken	Faulty connection Connection came loose	Check Elektronikon module (/LED)/A-meter Check cables/connections Replace defective components (contact BeaconMedaes

	Insufficient or no Insulation	Faulty insulation	Check cables/connections Replace defective components (contact BeaconMedaes)
LAN/Local switch	LAN/Local switch: does not open	Faulty button Faulty control module Bad wire connections	Check button orientation with regard to label Check connections
	LAN/Local switch: does not close	Faulty button Faulty control module Bad wire connections	Check button orientation with regard to label Check connections
Oil level switch (option)	Doesn't indicate when oil level is too low	Wrong assembly Wrong switch Switch fault Short circuit	Check orientation Check switch Replace defective components (contact BeaconMedaes)
	Indicates too low level while level is O.K.	Level switch is installed as <<Rise to open>> instead of <<Fall to open>> Broken wire	Check orientation Check switch Replace defective components (contact BeaconMedaes)
A-meter	Does not indicate (correct) current	Faulty connection Faulty component	Check in test procedure Check connections Replace defective components (contact BeaconMedaes)
Main switch	Does not connect	Contactor is blocked open	Check contactor Replace defective components (contact BeaconMedaes)
	Does not disconnect	Contactor is blocked closed	Check contactor Replace defective components (contact BeaconMedaes)
	Door can be opened	Lock does not work	Check during test and commissioning and regularly (e.g. during servicing)
Power supply cable ES-VAC	No/inadequate power	Supply problem Broken cables High contact resistance Power cable mechanically damaged	Check Elektronikon module (/LED)/A-meter Check cables/connections Replace defective components (contact BeaconMedaes)

Component	Condition	Potential cause of the fault	Remedy
Earthing	Earthing of hoses broken	Badly connected during production Connection broken during production	Check during test and commissioning and regularly (e.g. during servicing)

Instruction book, labels and plates

Component	Condition	Potential cause of the fault	Remedy
Instruction book	Not present or not clearly readable No clear instructions and/or explanations	Soiled Not delivered Disappeared Bad copy or translation	Replace (contact BeaconMedaes)
Rotation indicators for motor	Missing or flipped direction	Not present Not readable or hard to read Applied in flipped direction at supplier Soiled Covered	Adjust Clean Replace
Electrocution warning label	Live components are not identified	Not present Not readable or hard to read Not in the correct location Soiled Covered	Adjust Clean Replace
Automatic operation LED	LED not lit: people are not adequately warned	Failed internal electrical connection Soiled Covered	Re-download software
Service diagram	No explanation of electrical components and/or wiring	Not present Not readable or hard to read	Replace (contact BeaconMedaes)
Warning sticker	No warning	Not present Not readable or hard to read Not in the correct location Soiled Covered	Clean Replace
Data label	No/wrong/incomplete information	Not present Not readable or hard to read Not in the correct location Soiled Covered	Clean Replace
Number indication label	No information	Not present Not readable or hard to read Not in the correct location Soiled Covered	Clean Replace

10 Technical data

10.1 Electric cable size

Important warning

	To preserve the protection degree of the electric cubicle and to protect its components from dust from the environment, it is mandatory to use a proper cable gland when connecting the supply cable to the cubicle.
---	--

	<ul style="list-style-type: none"> The voltage on the terminals of the pump controller cabinets must not deviate more than 10% of the nominal voltage (for the 50 Hz variants) (5 % for the 60 Hz variants). It is however highly recommended to keep the voltage drop over the supply cables at nominal current below 5 % of the nominal voltage (IEC 60204-1). If cables are grouped together with other power cables, it may be necessary to use cables of a larger size than those calculated for the standard operating conditions. Use the original cable entry. See section Dimension drawings. Local regulations remain applicable if they are stricter than the values proposed below.
---	--

Supply Cables calculation IEC

For IEC designed control panels, the below suggested **cable sections** are calculated according to IEC 60364-5-52 electrical installations of buildings, part 5: selection and erection equipment, section 52: current carrying capacities in wiring systems.

<p>Table A.52-4 (52-C3) - Current-carrying capacities in Amperes for methods of installation in table A.52-1 (52-B1) - PVC insulation / three loaded conductors / copper. Conductor temperature: 70° C / Ambient temperature: 30° C in air, 20° C in ground. Temp conversion for 30° C, 40° C and 45° C.</p>

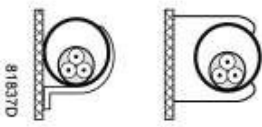
	<p>Installation methods of table A.52-1 B2 Multi-core cable in conduit on a wooden wall.</p>
---	---

Method B2		
Ambient temp. 30° C	Ambient temp. 40° C	Ambient temp. 45° C

Current (A)	Cable size mm2	Current (A)	Cable size mm2	Current (A)	Cable size mm2
<15	1,5	<13	1,5	<12	1,5
<20	2,5	<17	2,5	<16	2,5
<27	4	<23	4	<21	4

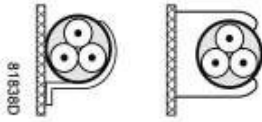

Installation methods of table A.52-1
C
Single core or multi core cable on a wooden wall.

Method C					
Ambient temp. 30° C		Ambient temp. 40° C		Ambient temp. 45° C	
Current (A)	Cable size mm2	Current (A)	Cable size mm2	Current (A)	Cable size mm2
<17	1,5	<15	1,5	<14	1,5
<24	2,5	<21	2,5	<19	2,5
<32	4	<28	4	<25	4

9.2 Fuse values

Fuse calculations for IEC are done according to IEC 60364-4-43 - electrical installations of buildings, part 4: protection for safety, section 43: protection against overcurrent. Fuse sizes are calculated in order to protect against short circuit.

The mVAC cubicles are foreseen with fuses and a main switch per pump, but it is recommended to also install fuses in the supply lines and a general main switch. Fuse type aM is recommended.

The cubicles are also foreseen with an overload protection. The overload value is given here for information purposes.

	Voltage	Freq.	Approval	Current (1)	Main fuses (2)	Overload relay (3)
	(V)	(Hz)		(A)	(A)	(A)
RA0040	400	50	IEC	2.9	12	3.3
RA0040	380	60	IEC	4.0	12	4.6
RA0063	400	50	IEC	3.8	12	4.4
RA0063	380	60	IEC	5.7	12	6.6
RA0100	400	50	IEC	5.2	12	6.0
RA0100	380	60	IEC	7.4	12	8.5
RA0255	400	50	IEC	12.4	25	15.5
RA0255	380	60	IEC	18.5	25	21.3
RA0305	400	50	IEC	15.6	25	18.0
RA0305	380	60	IEC	20.8	25	23.0

Remarks :

(1): Nominal motor current

(2): Maximal fuse size (IEC class gL/gG) - to be installed by customer - see F0' (and F10) on service diagram (3): see F21 on service diagram

10.3 Reference conditions and limitations

Reference conditions

Condition	Unit	Value
Inlet pressure	mbar(e)	-600
Atmospheric pressure	mbar(a)	1013
Pressure drop bacteria filter	mbar	30
Exhaust back pressure	mbar	0
Air inlet temperature	°C	20
Ambient temperature	°C	20
Oil type		Standard: ISO-100 mineral based oil (optional: PAO oil)

Limitations for operation

Condition	Unit	Value
Maximum atmospheric pressure	mbar(a)	1040
Minimum atmospheric pressure	mbar(a)	700
Maximum ambient temperature *	°C	40
Minimum ambient temperature	°C	1
Maximum inlet temperature	°C	40
Minimum inlet temperature	°C	1
Minimum pump inlet pressure	mbar(e)	-980
Maximum exhaust back pressure	mbar	60
Minimum exhaust back pressure	mbar	0
Maximum pressure drop bacteria filter	mbar	100

 Remark: To obtain pressure values in mmHg instead of mbar, multiply by 0.75.

* To guarantee service intervals as stated in chapter [Checks and intervals](#), it is recommended to use PAO oil if the average ambient temperature exceeds 30 °C.

10.4 Performance data

At the reference conditions described in the previous paragraph, the following performance data are given with a tolerance of 10%. FAA stands for the Free Air Aspiration in terms of mass through-put. FAA and volumetric flow rate are measured according to ISO 5167 / ISO 21360 / ISO 1607-1. The sound pressure level is measured as the maximum free

field noise level at 1 m distance from the pump according to ISO 2151 / DIN 45635.

HTM 02-01 50 Hz

mVAC type	Unit	250	330	500	660	1000	1280	2560	3300	3840	4950	6000	6600
FAA	l/min	250	330	500	660	1000	1280	2560	3300	3840	4950	6000	6600
Volume flow rate	m ³ /h	40	52	79	105	159	203	406	524	609	786	952	1047
Nominal power per pump	kW	1.1	1.5	2.2	1.5	2.2	5.5	5.5	7.5	5.5	7.5	7.5	7.5
Sound pressure per pump	db(A)	67	69	70	69	70	72	72	75	72	75	75	75

HTM 02-01 60 Hz

mVAC type	Unit	300	400	620	800	1200	1500	3000	3900	4500	5850	7800
FAA	l/min	300	400	620	800	1200	1500	3000	3900	4500	5850	7800
Volume flow rate	m ³ /h	48	63	98	127	190	238	476	619	714	928	1238
Nominal power per pump	kW	1.7	2.4	3.4	2.4	3.4	9.2	9.2	10.0	9.2	10.0	10.0
Sound pressure per pump	db(A)	67	75	72	75	72	74	74	77	74	77	77

HTM 2022 50 Hz

mVAC type	Unit	250	500	660	1000	1500	2560	3840	4950	6000	6600	8000
FAA	l/min	250	500	660	1000	1500	2560	3840	4950	6000	6600	8000
Volume flow rate	m ³ /h	40	79	105	159	238	406	609	786	952	1047	1270
Nominal power per pump	kW	1.1	1.1	1.5	2.2	2.2	5.5	5.5	7.5	7.5	7.5	7.5
Sound pressure per pump	db(A)	67	67	69	70	70	72	72	75	75	75	75

HTM 2022 60 Hz

mVAC type	Unit	300	500	800	1200	1860	3000	4500	5850	7800	9200
FAA	l/min	300	500	800	1200	1860	3000	4500	5850	7800	9200
Volume flow rate	m ³ /h	48	79	127	190	295	476	714	928	1238	1460
Nominal power per pump	kW	1.7	1.7	2.4	3.4	3.4	9.2	9.2	10.0	10.0	10.0
Sound pressure per pump	db(A)	67	67	75	72	72	74	74	77	77	77

Altitude corrections

These performance data apply for the reference condition of 1013 mbar atmospheric pressure. When the mVAC is installed at an altitude where the average atmospheric pressure is lower (e.g. more than 50 m above

sea level), the following derating table must be used. Multiply the required hospital flow rate by the altitude derating factor to obtain the flow rate which will be used to size the plant.

Interpolate as required, or use the calculation tool. Contact BeaconMedaes.

Altitude (m)	Atmospheric pressure (mbar)	Flow rate derating factor (-)
50	1007	1
500	955	1.09
1000	900	1.19
1500	846	1.3
2000	795	1.42

Also the cut-in and cut-out settings need to be adjusted in the central controller software (see: [Central controller operation](#)) according to the following table.

Altitude (m)	Atmospheric pressure (mbar)	Cut-in (mbar)	Cut-out (mbar)
50	1007	-670	-870
500	955	-670	-850
1000	900	-670	-800
1500	846	-670	-740
2000	795	-630	-690

10.5 Design data

mVAC HTM 02-01 / ISO 7396-1

50 Hz	mVAC	250	330	500	660	1000	1280	2560	3300	3840	4950	6000	6600
60 Hz	mVAC	300	400	620	800	1200	1500	3000	3900	4500	5850	7800	-
Pump type	RA	0040	0063	0100	0063	0100	0255	0255	0305	0255	0305	0305	0305
Number of pumps		3	3	3	4	4	3	4	4	5	5	6	6
Oil capacity per pump	l	1.0	2.0	2.0	2.0	2.0	6.5	6.5	6.5	6.5	6.5	6.5	6.5
Cooling air flow per pump	m /s	0.1	0.1	0.2	0.1	0.2	0.3	0.3	0.4	0.3	0.4	0.4	0.4
Weight per pump	kg	38	52	70	52	70	190	190	190	190	190	190	190

mVAC HTM 2022

50 Hz	mVAC	250	500	660	1000	1500	2560	3840	4950	6000	6600	8000
60 Hz	mVAC	300	500	800	1200	1860	3000	4500	5850	7800	-	9200

Pump type	RA	0040	0040	0063	0100	0100	0255	0255	0305	0305	0305	0305
Number of pumps		2	3	3	3	4	3	4	4	5	5	6
Oil capacity per pump	l	1.0	1.0	2.0	2.0	2.0	6.5	6.5	6.5	6.5	6.5	6.5
Cooling air flow per pump	m /s	0.1	0.1	0.1	0.2	0.2	0.3	0.3	0.4	0.4	0.4	0.4
Weight per pump	kg	38	38	52	70	70	190	190	190	190	190	190

11 Usability

Intended use

1. Description

The mVAC plant provides a source for vacuum (suction) for a variety of applications in the hospital, mainly in operating theatres, intensive care, emergency and respiratory units. Specific applications include:

- Wound drainage
- Assisted wound closure
- Chest and lung drainage
- Removal of excess blood during surgery
- Collection of other bodily fluids
- Gastric emptying
- Cleaning endotracheal tubes
- Liposuction (lipoplasty)

2. mVAC application specification

• **Medical purpose**

1. To provide vacuum (suction) for a variety of applications in the hospital, mainly in operating theatres, intensive care, emergency and respiratory units
2. Condition(s) or disease(s) to be screened, monitored, treated or diagnosed: none

• **Patient population**

1. Age: newborn to geriatric
2. Weight: not relevant
3. Health: not relevant
4. Nationality: multiple
5. Patient state:
 - Patient is operator: patient is never intended to be the operator
 - Patient is not operator: default case

• **Part of the body or type of tissue applied or interacted with**

Direct contact is not foreseen, the device connects to the patient via a transport piping system.

• **Intended operator**

1. Education:
 - minimum: At least 21 years old, high school or equivalent.
 - maximum: none
2. Knowledge:
 - minimum: Can read and understand westernized Arabic numerals. Basic technical knowledge and software understanding required.
 - maximum: none

3. Language understanding: Language of the instruction book and preferably also English
 4. Experience:
 - minimum: no special experience necessary
 - maximum: none
 5. Permissible impairments: Mild reading vision impairment or vision corrected to log MAR 0,2 (6/10 or 20/32), at least one arm/hand capable of guiding device, average degree of ageing-related short term memory impairment.
- **Applications**
 1. Environment:
 - general: plant room in a hospital
 - conditions of visibility: well lit room
 - physical: 1 to 40°C
 2. frequency of use: every day intermittently or continuously
 3. mobility: stationary device

Primary operating functions

1. **Critical functions**
: Switching On
Maintenance
2. **Frequent functions:**
None

Risk analysis

1. **Intended use**
: See above
2. **Operator Profile:**
See above : **Intended operator**
3. **Things that could go wrong :**
Sources: literature, complaint file, sales force, nursing experts, risk analysis.
 - a. During normal use: See: [Faults and remedies](#) e.g. loss of vacuum
 - b. Use errors: Misuse / no or wrong maintenance
 - c. Environment:
 - above 40 °C
 - below 1 °C
 - d. Patient: not applicable
 - e. Reading: not applicable
 - f. Hygiene: not applicable
 - g. Application: outside of operating room
4. **Task requirements:**
Maintenance

5. **The context of use:**
See above: **Applications**
6. **Information on Hazards known for existing similar device:** Included in **Things that could go wrong**.
7. **Resulting Hazards:**
See [section 2.3 for WARNINGS](#) and [2.4 for CAUTIONS](#).
8. **Preliminary review of the Operator-Equipment interface concept:** According to design process.
Conclusion: no issue.

Use scenarios

Worst case scenarios to provide a basis for validation with <<Patient = Operator>> is not applicable.

- Patient is never intended to be the operator.

1. **Operator actions related to primary operating functions:** See operation userguide
2. **Operator-equipment interface requirements for the primary operating functions:** According to design process.
3. **Operator-equipment interface requirements for those use scenarios that are frequent or related to basic safety or essential performance:**
According to design process.

12 Reporting Serious Incidents

In accordance with Regulation (EU) 2017/745 (MDR), a notice to the user and/or patient that any serious incident that has occurred in relation to the device should be reported to the manufacturer and the competent authority of the Member State in which the user and/or patient is established.

A serious incident is defined as any incident that directly or indirectly led, might have led, or might lead to:

- the death of a patient, user, or other person,
- the temporary or permanent serious deterioration of a patient's, users, or other person's state of health,
- a serious public health threat.

These events may occur during device use, due to device failure, malfunction, labeling error, or IFU omission.

User Responsibilities

The user or healthcare professional should report any suspected serious incident without delay. (Immediately, but no later than 2 calendar days after the manufacturer becomes aware of the threat.)

If a serious incident is suspected, users must:

- Immediately discontinue use of the device, if safe to do so
- Retain the device (if possible) for investigation
- Notify the manufacturer without delay using the contact information below
- Report the event to the local competent authority of their country as required

Contact Information for Reporting Serious Incidents

- **Manufacturer:** www.beaconmedaes.com
- **Support Email:** BMCS@beaconmedaes.com
- **Phone:** 01246 474242
- **Authorized Representative (EU):** Atlas Copco Airpower n.v. Boomsesteenweg 957 2610 Wilrijk-Belgium
- **Competent Authority:** https://health.ec.europa.eu/md_authorities

13 Online access:

IFUs are available in digital format on the BeaconMedaes BeaconMedaes official website [HTM/ISO products \(beaconmedaes.com\)](http://HTM/ISO_products(beaconmedaes.com)), where the latest versions can be accessed and downloaded. For previous versions, end users may contact us via the "Request Information" section on the website.

14 Appendix

14.1 Declaration of contamination status

From (consigner) : Address	To (consignee) : Address
Reference Emergency tel.	Reference

Type of equipment

Manufacturer

Description of

equipment Other

identifying marks

Model No.

Serial

No.

Fault

Is the item contaminated ?	Yes * <input type="checkbox"/>	No <input type="checkbox"/>	Don't know <input type="checkbox"/>
* State type of contamination: blood, body fluids, respired gases, pathological samples, chemicals (including cytotoxic drugs), radioactive material or any other hazard			
Has the item been decontaminated ?	Yes + <input type="checkbox"/>	No ++ <input type="checkbox"/>	Don't know <input type="checkbox"/>
+ What method of decontamination has been used ? Please provide details			
Cleaning :			
Disinfection :			
Sterilisation :			
++ Please explain why the item has not been decontaminated ?			

Contaminated items should not be returned without prior agreement of the recipient

This item has been prepared to ensure safe handling and transportation :	
Name	Position
Signature	
Date	Tel.



Atlas Copco Airpower n.v.
Boomssteenweg 957
2610 Wilrijk - Belgium



BeaconMedaes Limited
Greaves Close, Markham Vale, Chesterfield S44 5FB, UK

