

- Notes:
1. DISCHARGE CONNECTION HAS INTEGRATED FLEX HOSE DESIGN.
 2. SYSTEM WEIGHT: 4838 LBS.
 3. ☒ INDICATES LIFTING POINT.
 4. ● DENOTES CENTER OF GRAVITY.

SYSTEM CONNECTIONS	
ID	DESCRIPTION
D	DISCHARGE LOCATION
C	CONDENSATE DRAIN LOCATION

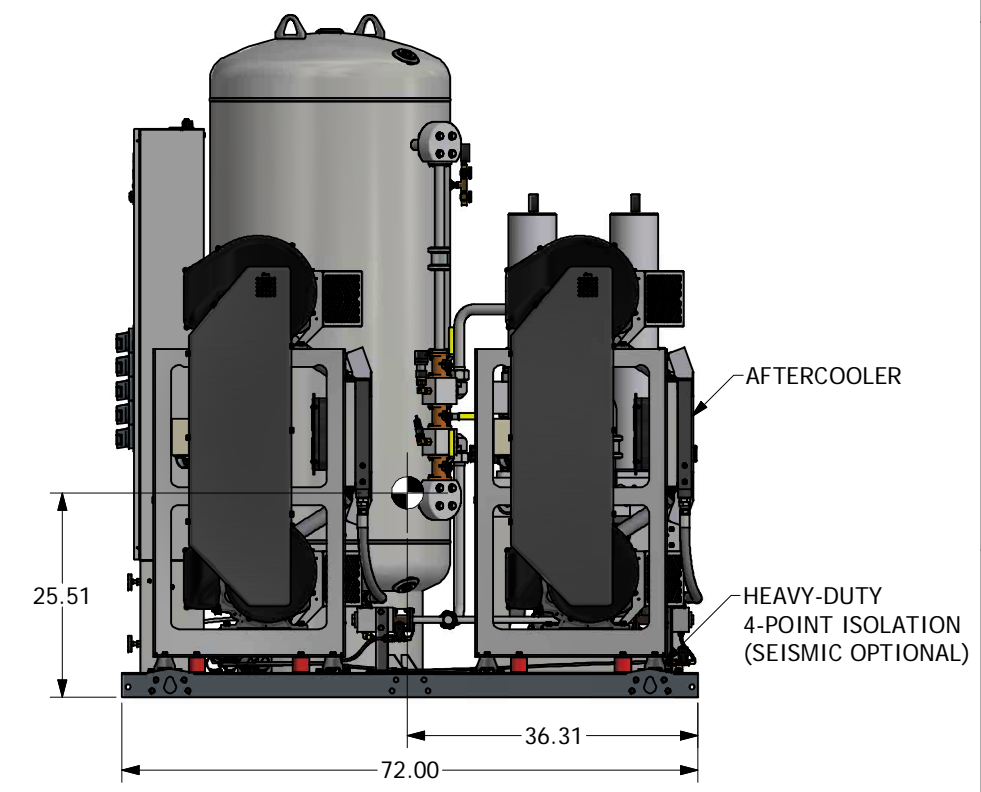
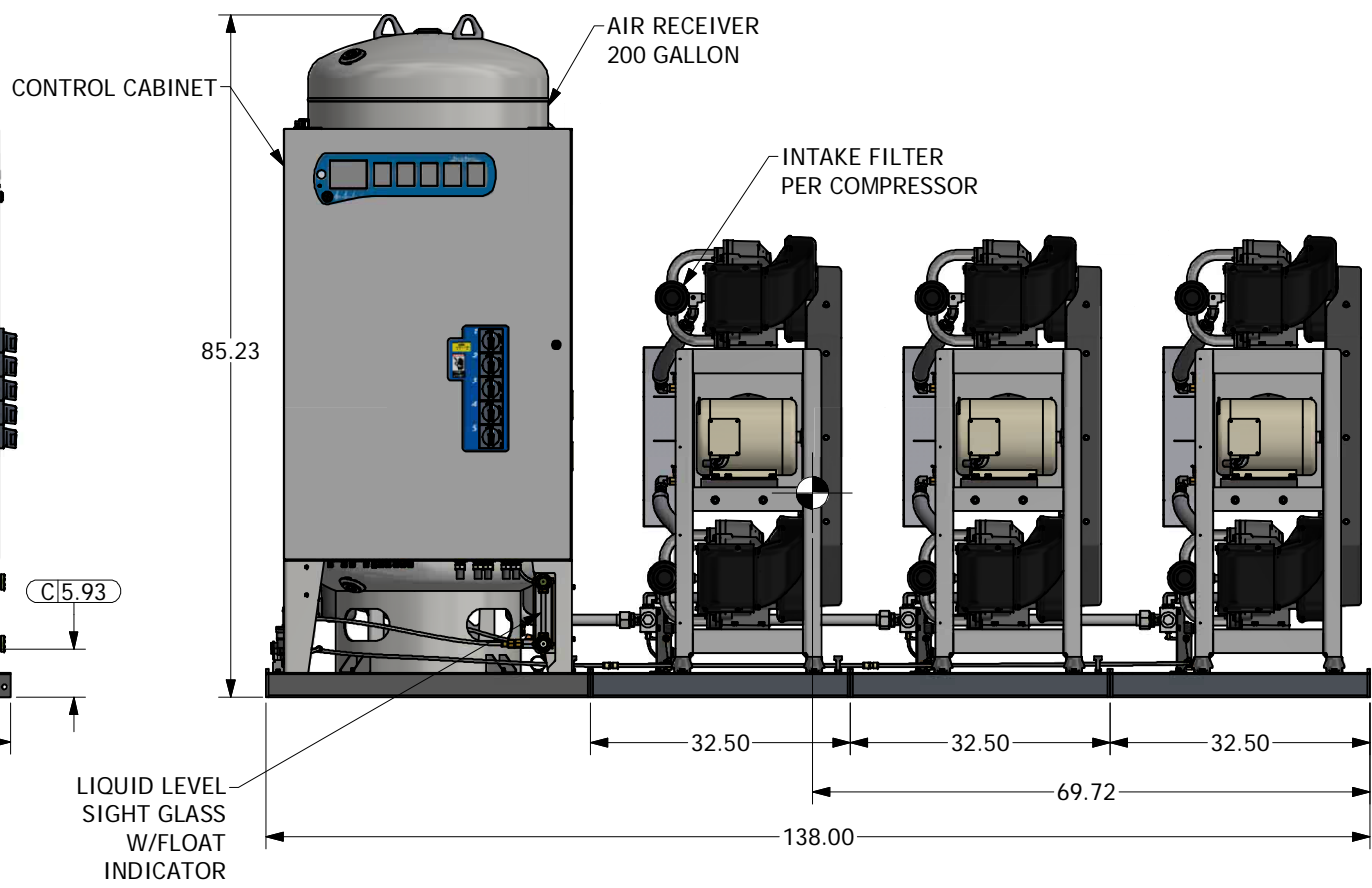
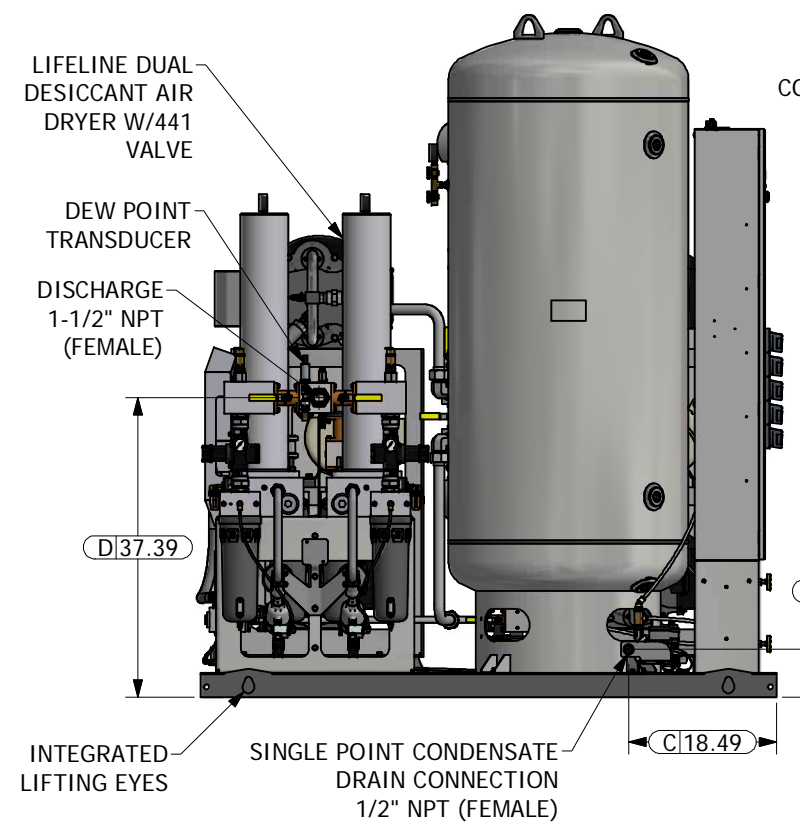
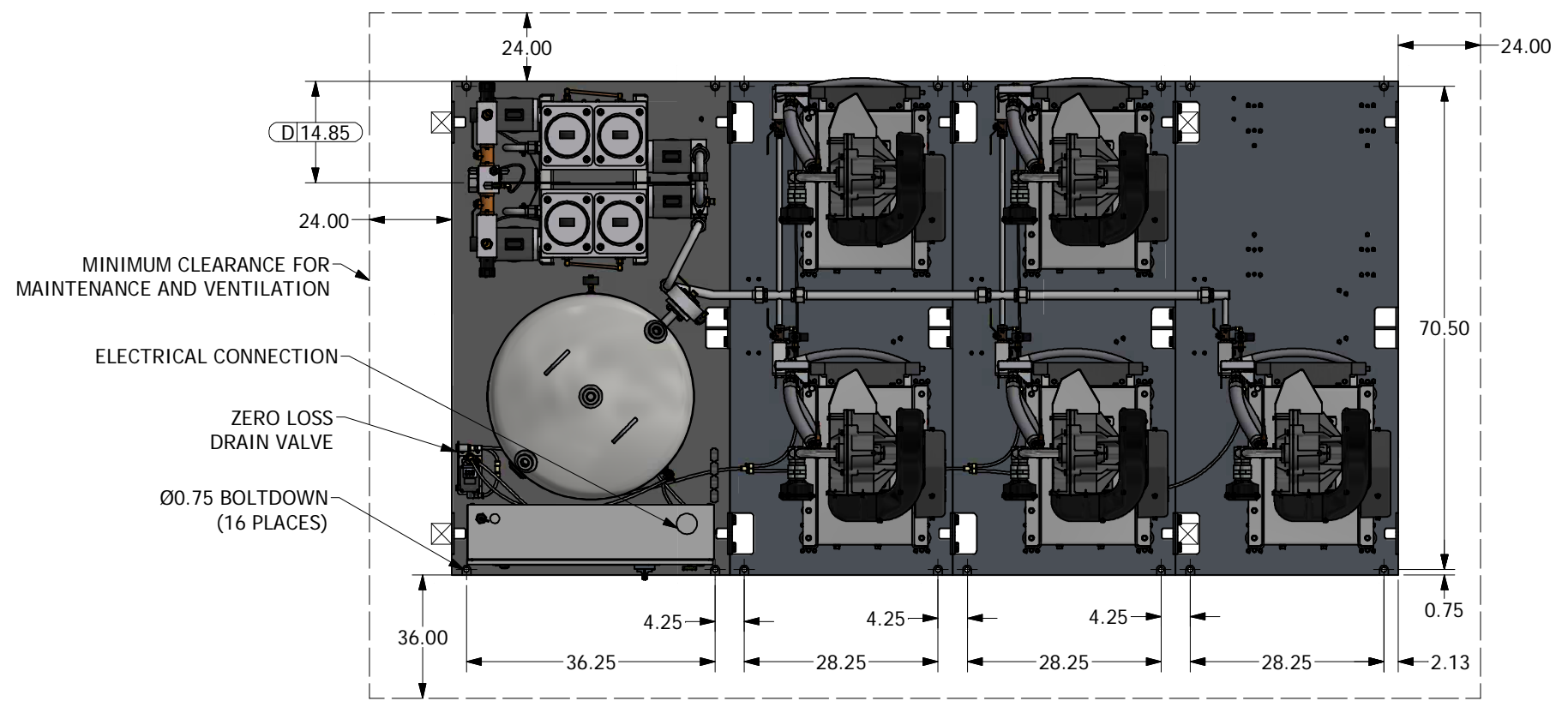

Revised: MD	Date: 4/9/2020	Drawn: GE CIA	Date: 3/29/2013
		This drawing and the information contained therein remain the property of BeaconMedes and may not be used for other than the purpose for which it is loaned without the expressed written permission from BeaconMedes Engineering.	
Description: GENERAL ASM - LAB AIR PX SCROLL SPC 15HP 10 BAR 200G W/ DESC DRYER		Part Number: 4107 8544 72 DN: HOP200057 Rev: 03 Sheet 1 of 1	
		Scale: D DO NOT SCALE THIS DOCUMENT	