

This drawing and the information contained thereon remain the property of BeaconMedics and may not be used for other than the purpose for which it is loaned without the expressed written permission from BeaconMedics Engineering.

- Notes:
1. SYSTEM WEIGHT: 653 LBS
 2. ☒ INDICATES LIFTING POINTS
 3. ● DENOTES CENTER OF GRAVITY

SYSTEM CONNECTIONS	
ID	DESCRIPTION
I	INLET LOCATION
D	DISCHARGE LOCATION
T	TANK DRAIN

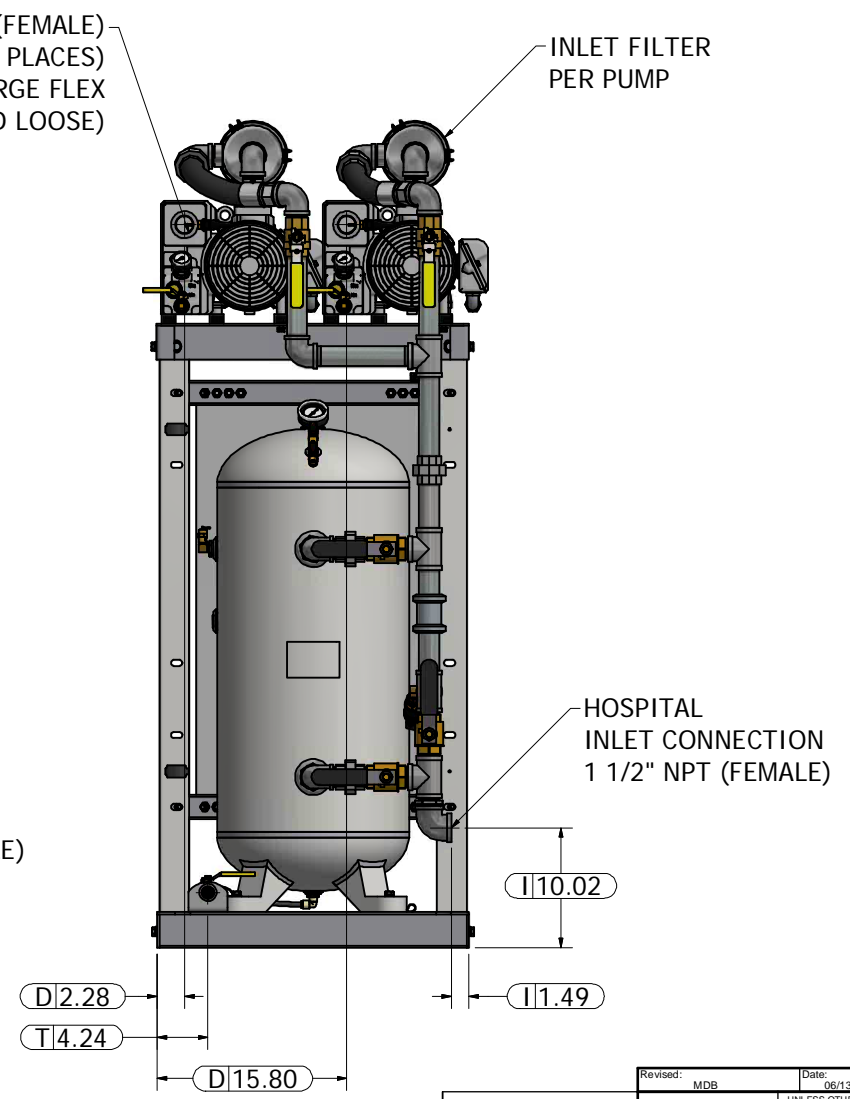
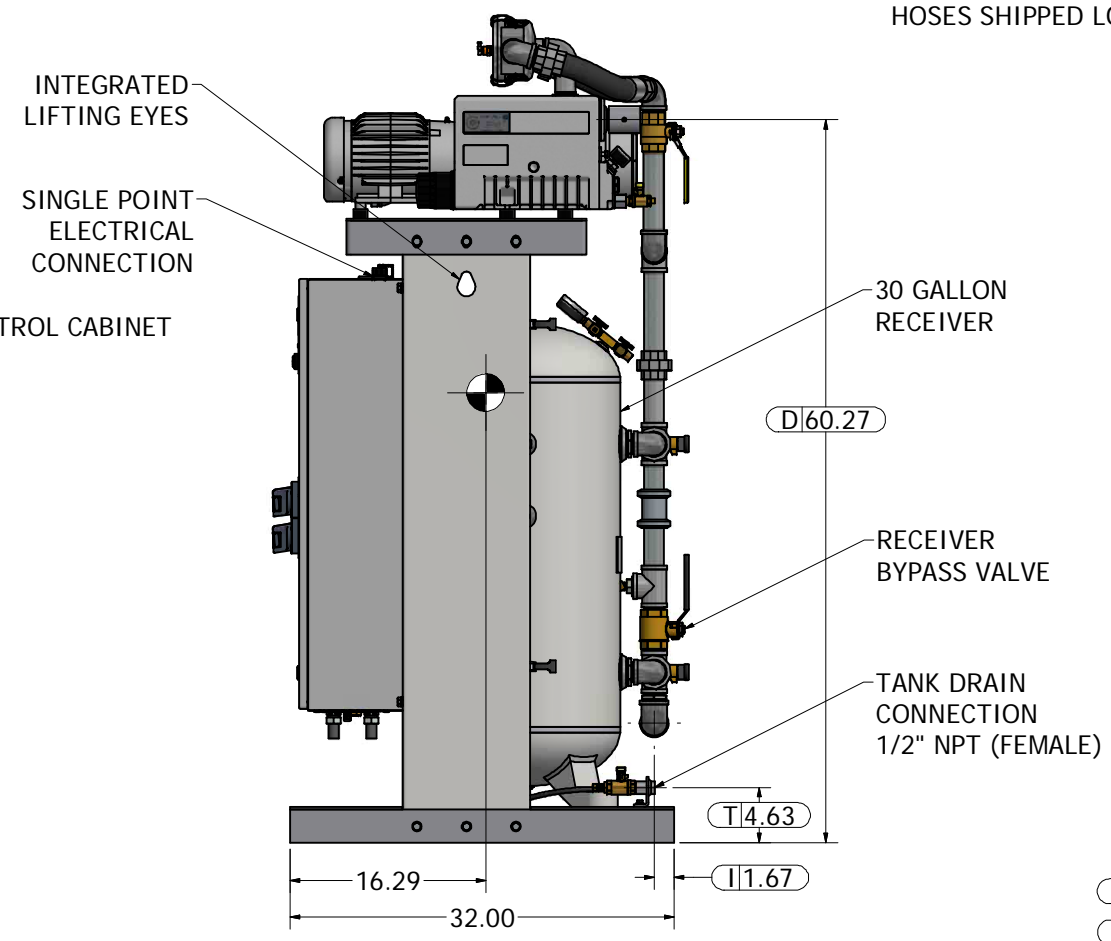
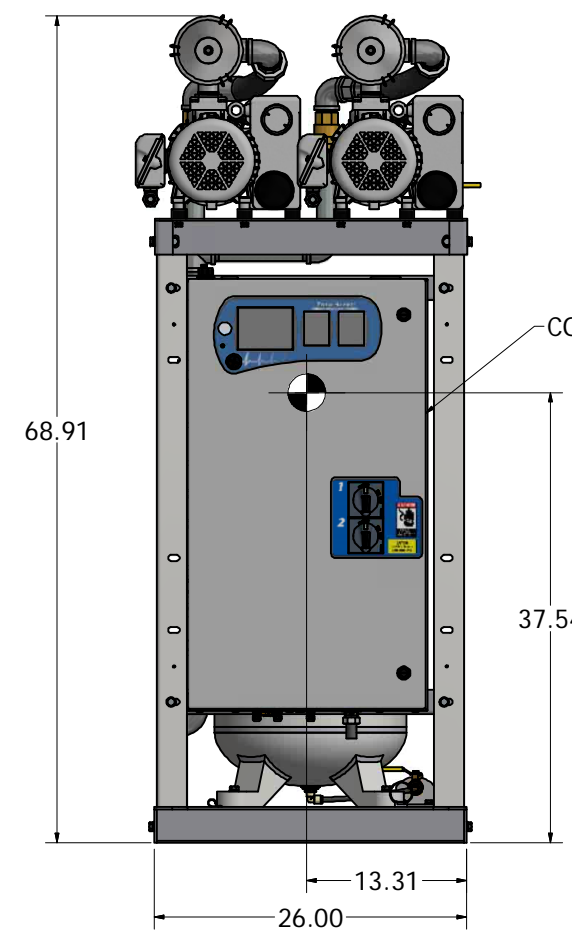
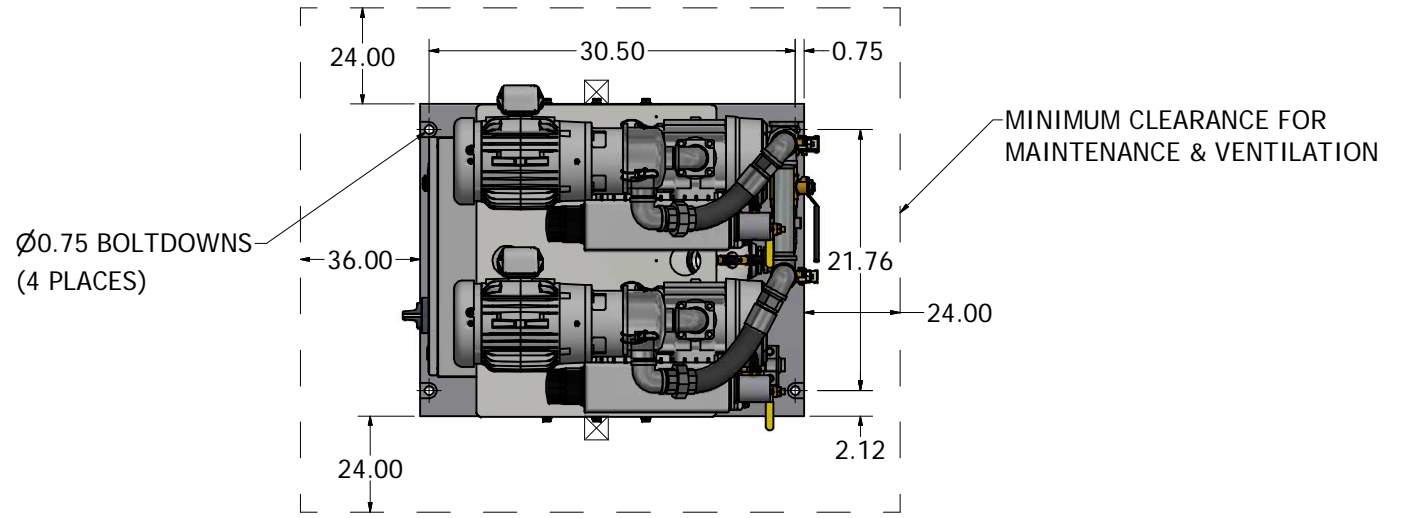

Revised: MDB	Date: 06/13/2019	Drawn: JOL	Date: 07/13/2015
UNLESS OTHERWISE SPECIFIED: ALL DIMENSIONS ARE TO BE INSPECTED		UNLESS OTHERWISE SPECIFIED ALL DIMENSIONS ARE IN INCHES AND TOLERANCES ARE: XX ± .02 XXX ± .005 ANGLES ± .5°	
Description: GENERAL ASSEMBLY DX 2HP LUBE VTM V 30G TAE		Part Number: 4107 8553 38	Scale: D
EQUIPMENT TO BE USED DURING RECEIVING INSPECTION SHALL BE PER QUALITY SYSTEM PROCEDURES		Rev: 02	Sheet 1 of 1