





This drawing and the information contained thereon remain the property of BeaconMedes and may not be used for other than the purpose for which it is loaned without the expressed written permission from BeaconMedes Engineering.

Notes:

1. SYSTEM WEIGHT: 680 LBS
2.  INDICATES LIFTING POINTS
3.  DENOTES CENTER OF GRAVITY

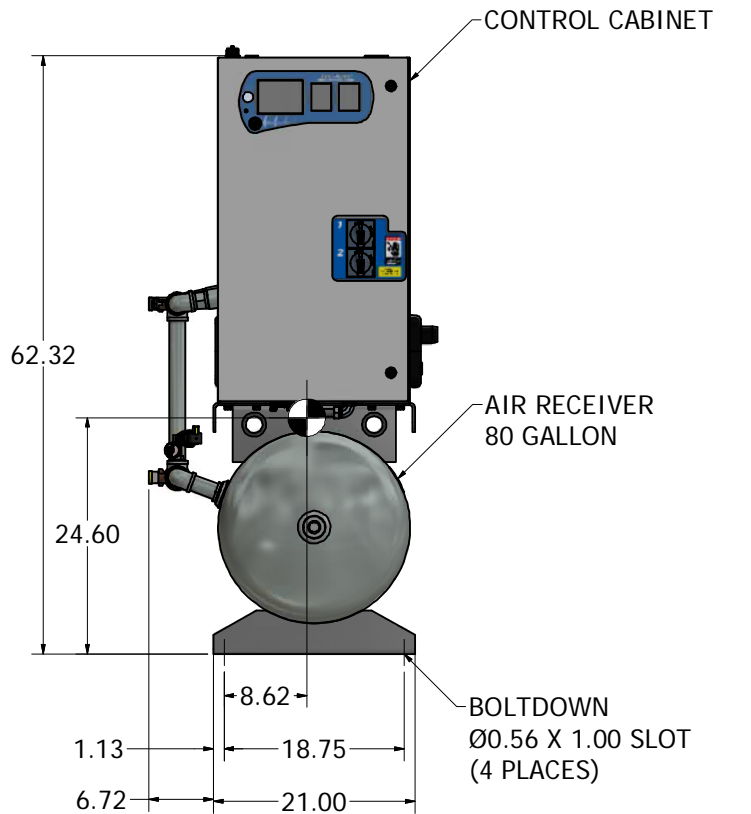
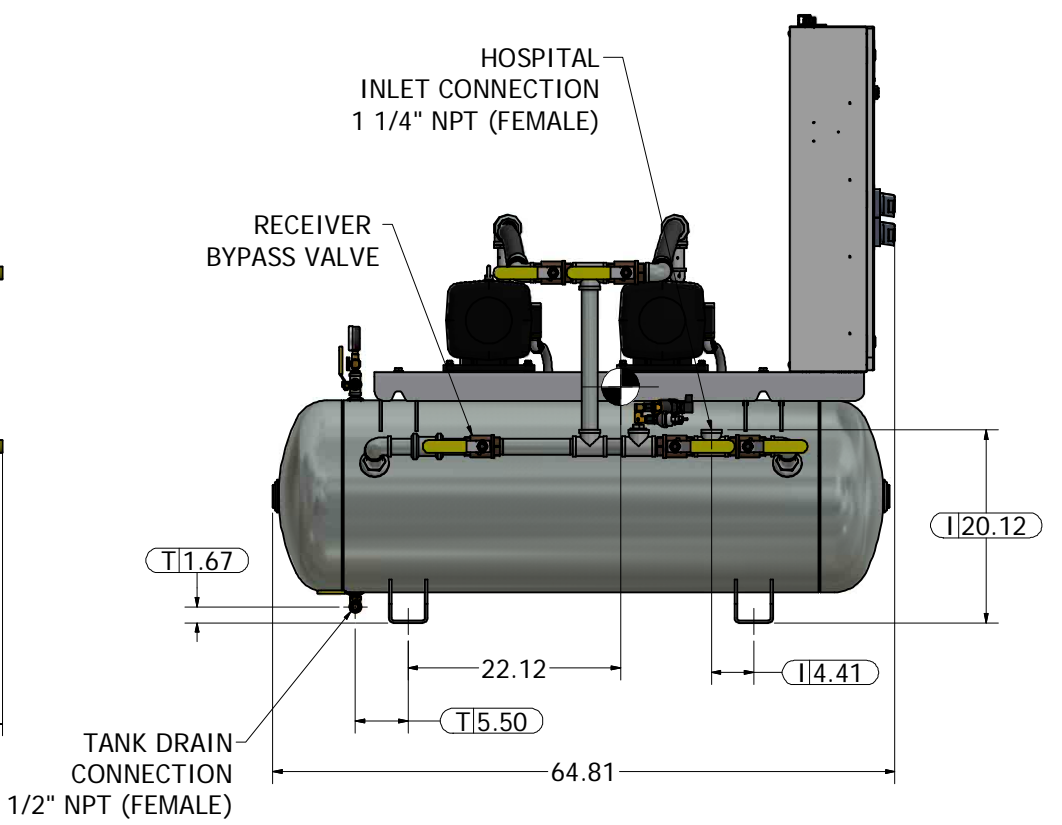
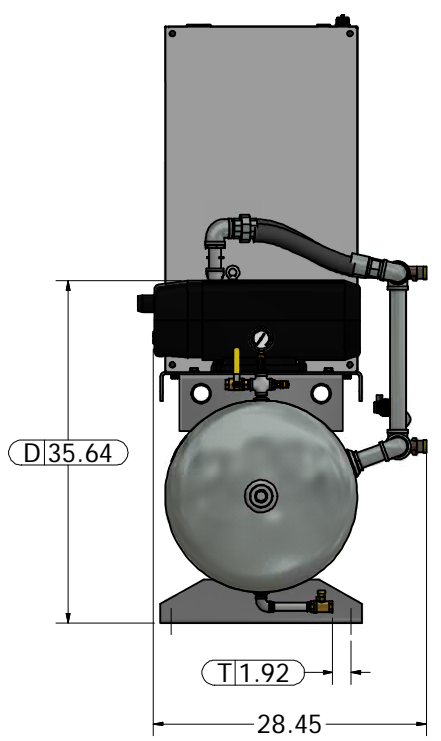
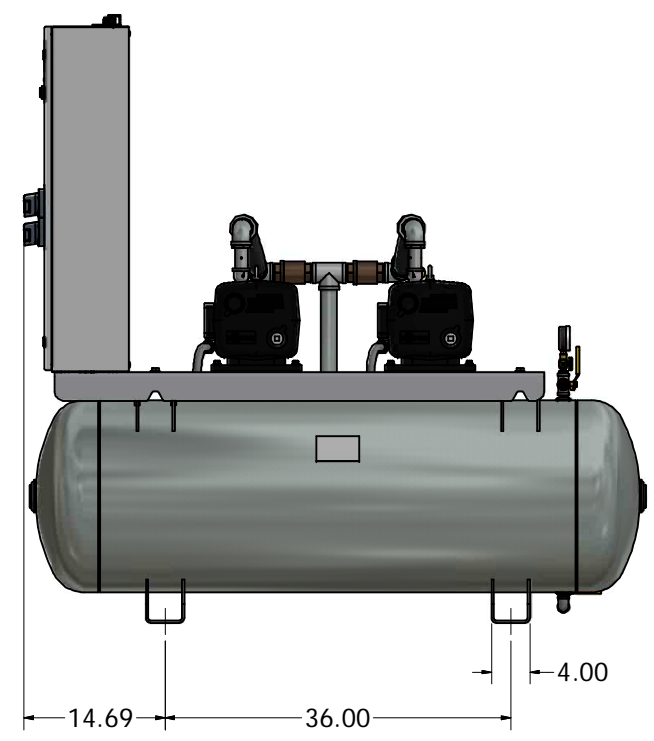
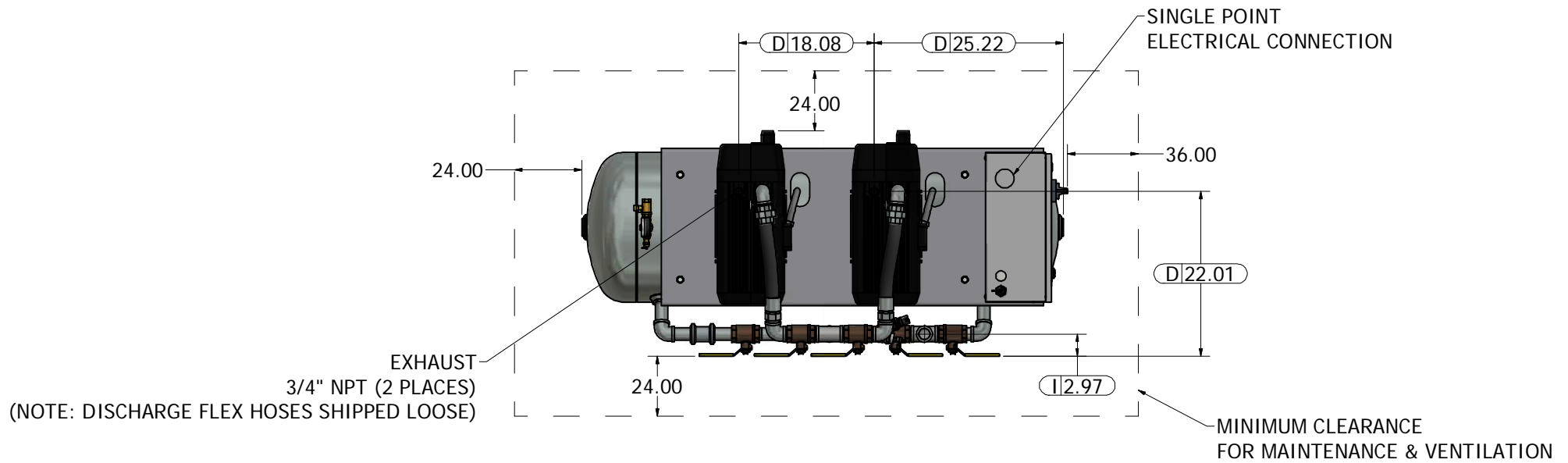
SYSTEM CONNECTIONS	
ID	DESCRIPTION
I	INLET LOCATION
D	DISCHARGE LOCATION
T	TANK DRAIN



Revised: MDB	Date: 05/13/2019	Drawn: JOL	Date: 07/03/2015
INSPECTION CHECKLIST UNLESS OTHERWISE SPECIFIED:   ALL ITEMS MARKED BY ONE OF THE ABOVE SYMBOLS ARE TO BE INSPECTED EQUIPMENT TO BE USED DURING RECEIVING INSPECTION SHALL BE PER QUALITY SYSTEM PROCEDURES		UNLESS OTHERWISE SPECIFIED ALL DIMENSIONS ARE IN INCHES AND TOLERANCES ARE: XX ± .02 XXX ± .005 ANGLES ± .5°	Scale: <b>D</b>
Description: GENERAL ASSEMBLY DX 2HP DRY HTM V 80G TAE		Part Number: 4107 8553 24	Rev: 02
DN: BM190344		Sheet 1 of 1	DO NOT SCALE THIS DOCUMENT