

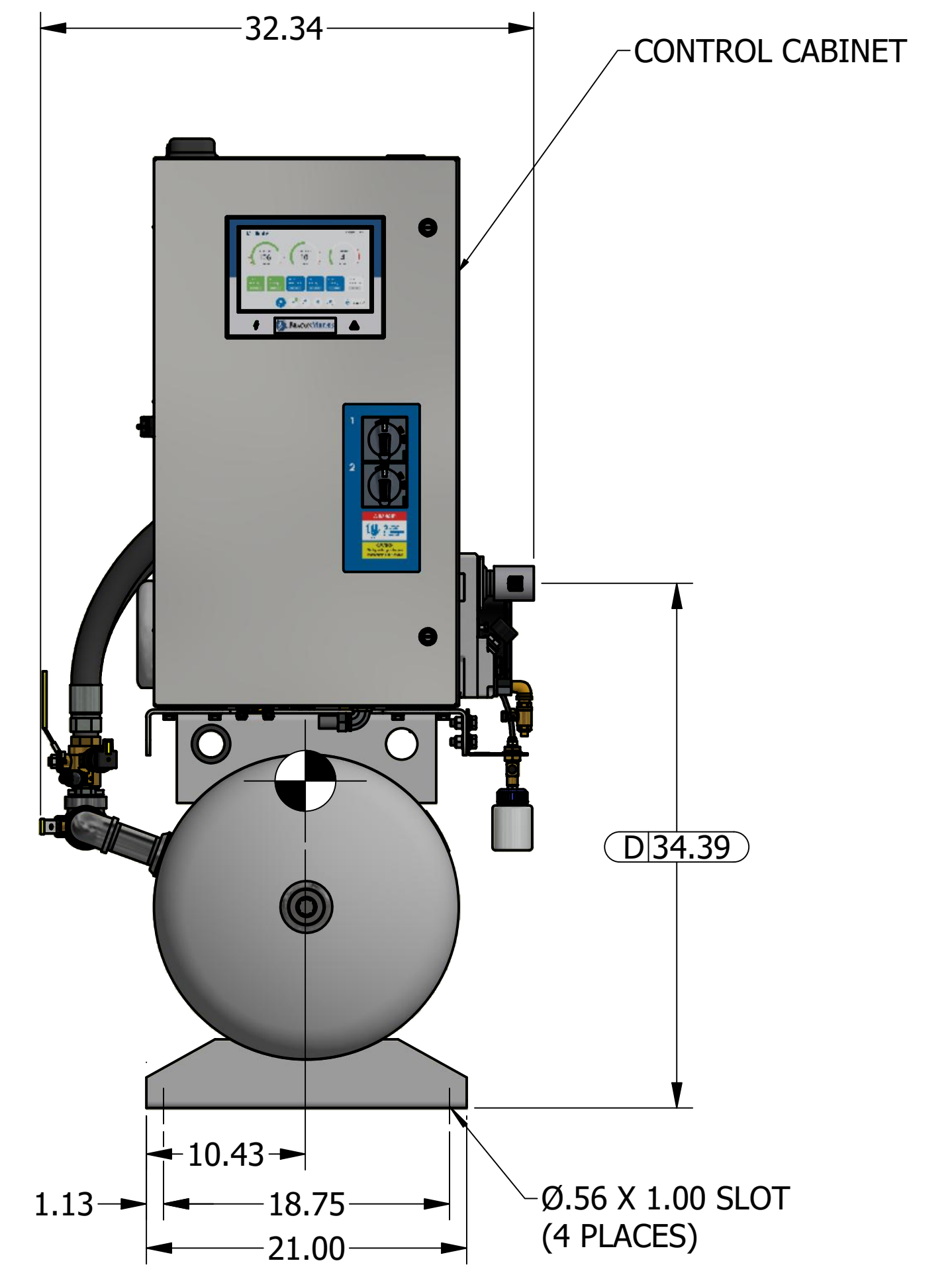

Notes:

1. SYSTEM WEIGHT: 720 LBS.
2.  DENOTES CENTER OF GRAVITY.

SYSTEM CONNECTIONS	
ID	DESCRIPTIONS
I	INLET LOCATION
D	DISCHARGE LOCATION
T	TANK DRAIN

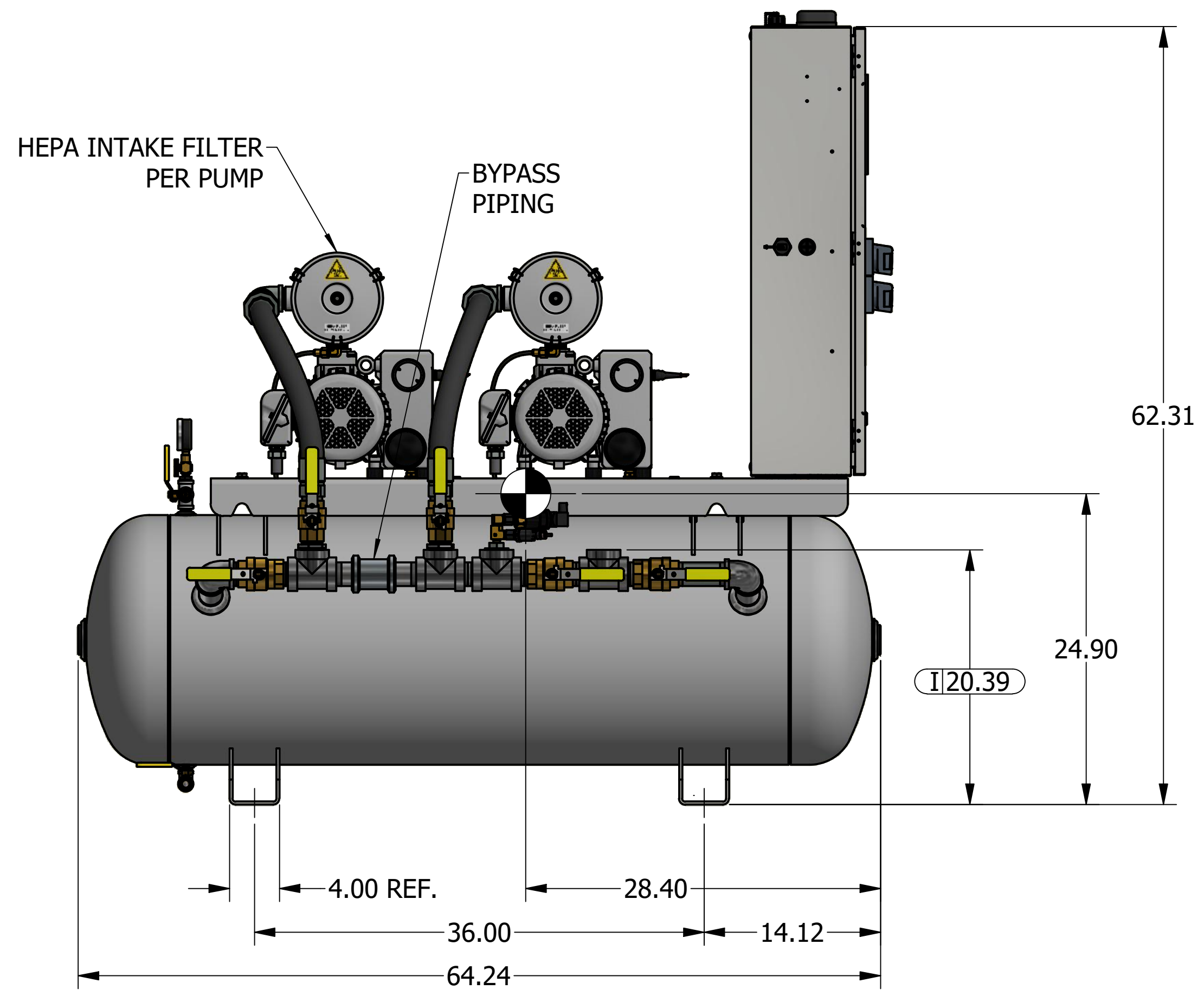
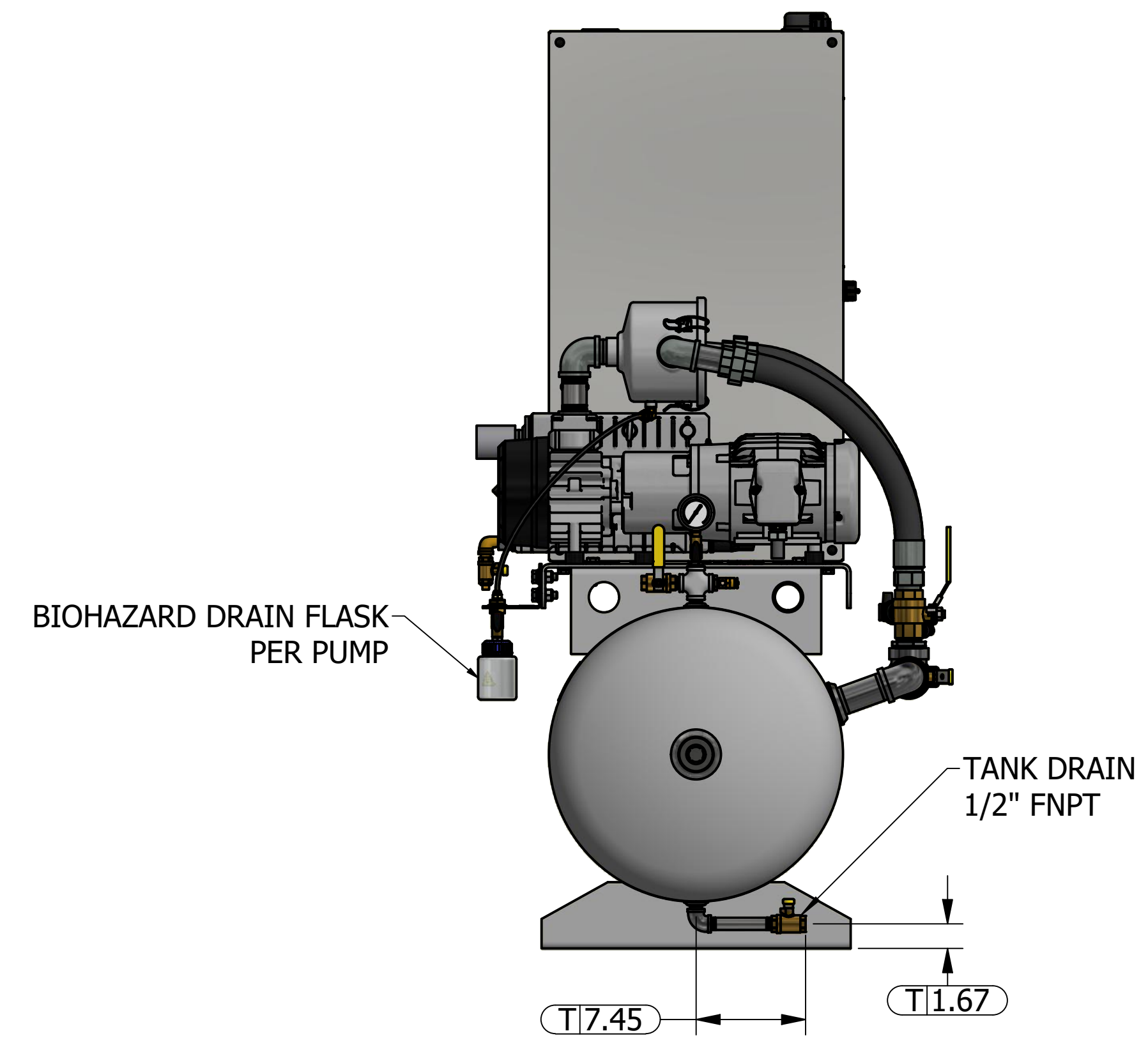
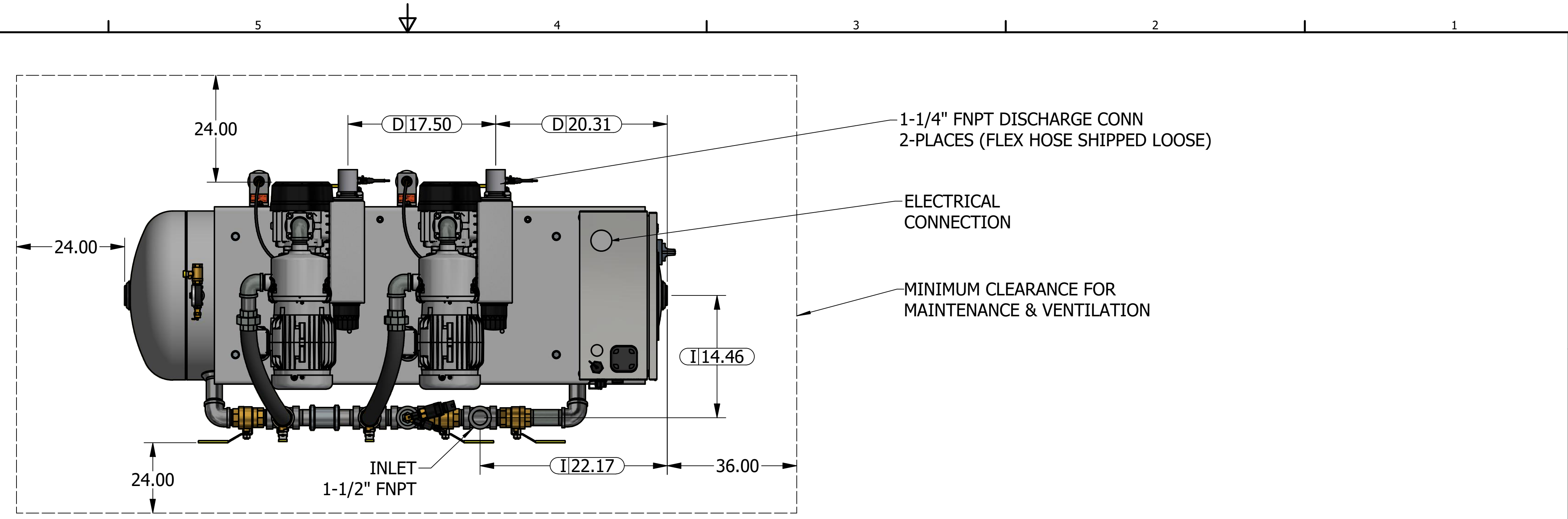

Revised: APS	Date: 3/29/2023	Drawn: Jeb	Date: 4/1/2011
		This drawing and the information contained herein remain the property of BeaconMedaes and may not be used for other than the purpose for which it is loaned without the expressed written permission from BeaconMedaes Engineering.	
Description: GENERAL ASSEMBLY DX 1.5HP LUBE VAC TANK MOUNTED 80G RECEIVER		Drawing Number: 4107 8530 63 Rev: 04 Sheet 1 of 1	