





This drawing and the information contained thereon remain the property of BeaconMedes and may not be used for other than the purpose for which it is loaned without the expressed written permission from BeaconMedes Engineering.

Notes:

1. SYSTEM WEIGHT: 470 LB
2.  INDICATES LIFTING POINTS
3.  DENOTES CENTER OF GRAVITY

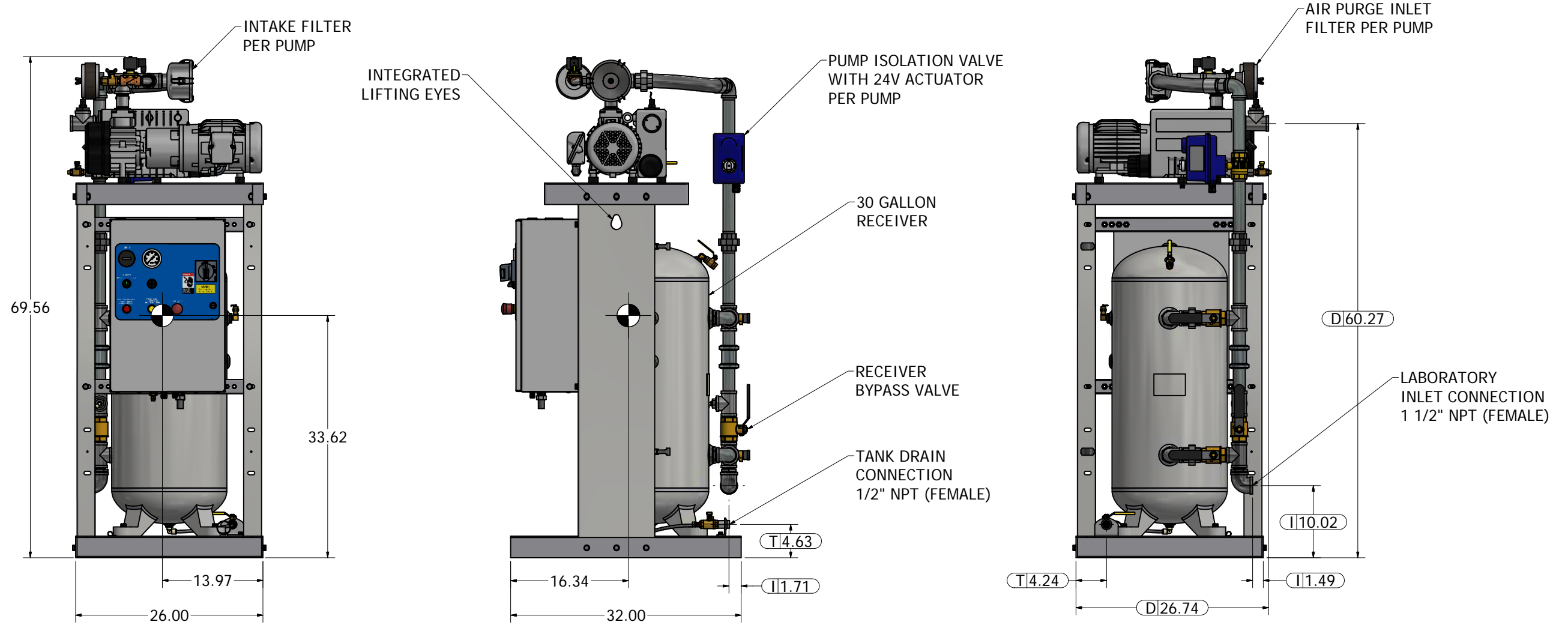
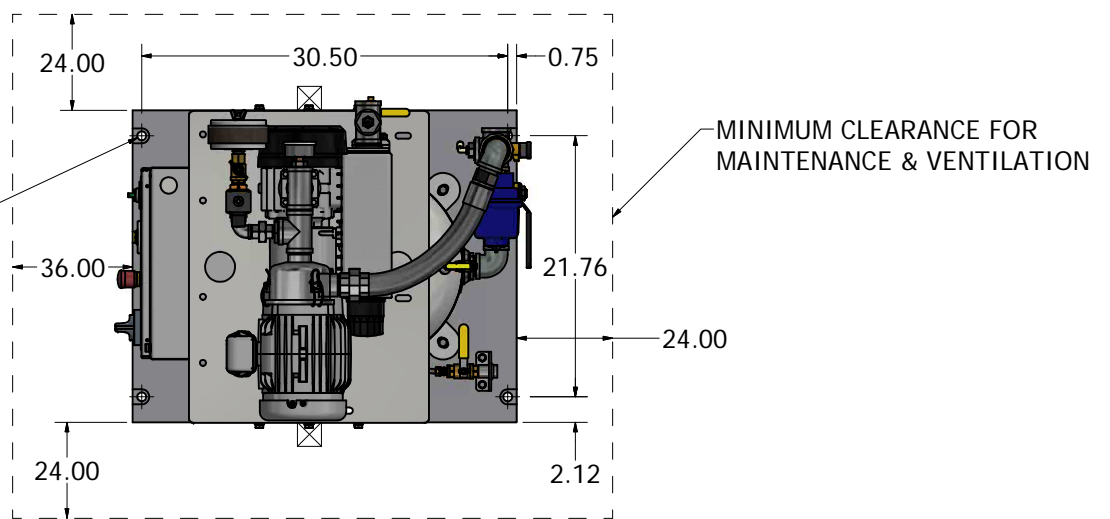
SYSTEM CONNECTIONS	
ID	DESCRIPTION
I	INLET LOCATION
D	DISCHARGE LOCATION
T	TANK DRAIN



Revised: MDB	Date: 7/26/2021	Drawn: MDB	Date: 11/30/2017
UNLESS OTHERWISE SPECIFIED:		UNLESS OTHERWISE SPECIFIED ALL DIMENSIONS ARE IN INCHES AND TOLERANCES ARE:	
 		XX ± .02 XXX ± .005 ANGLES ± .5°	
ALL ITEMS MARKED BY ONE OF THE ABOVE SYMBOLS ARE TO BE INSPECTED EQUIPMENT TO BE USED DURING RECEIVING INSPECTION SHALL BE PER QUALITY SYSTEM PROCEDURES		Description: GENERAL ASSEMBLY SX 1.5HP LAB LUBE VTM V 30G BASIC	Part Number: 4107 8562 75 DN: HOP211049 Rev: 01 Sheet 1 of 1 DO NOT SCALE THIS DOCUMENT