

Notes:

- DISCHARGE MUFFLERS WILL BE SHIPPED LOOSE.
- SYSTEM WEIGHT: 5,677 LBS.
- ☒ INDICATES LIFTING POINT.
- ⊙ DENOTES CENTER OF GRAVITY.

SYSTEM CONNECTIONS	
ID	DESCRIPTION
I	INLET LOCATION
D	DISCHARGE LOCATION
T	TANK DRAIN LOCATION
C	CONDENSATE DRAIN LOCATION

MINIMUM CLEARANCE FOR MAINTENANCE & VENTILATION

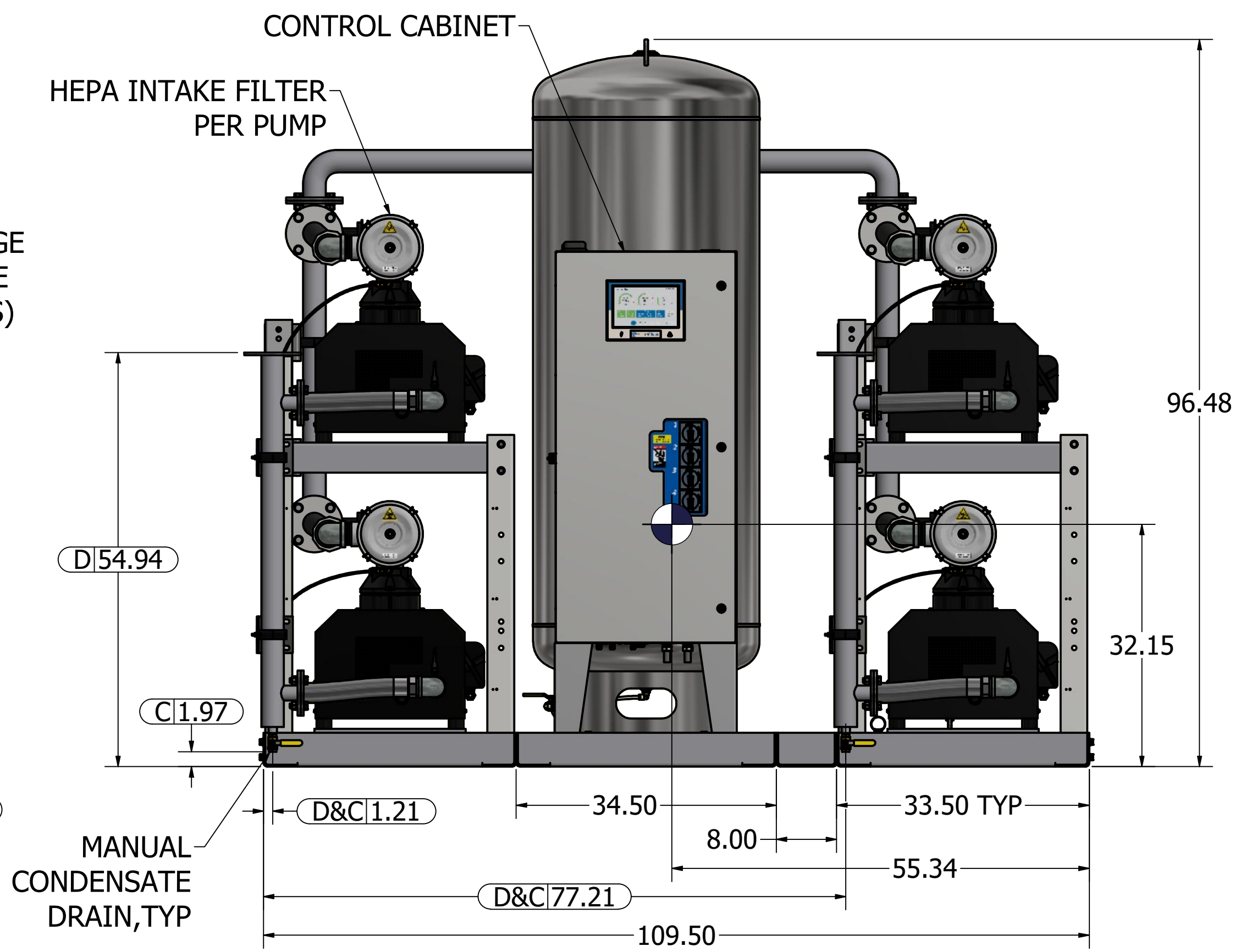
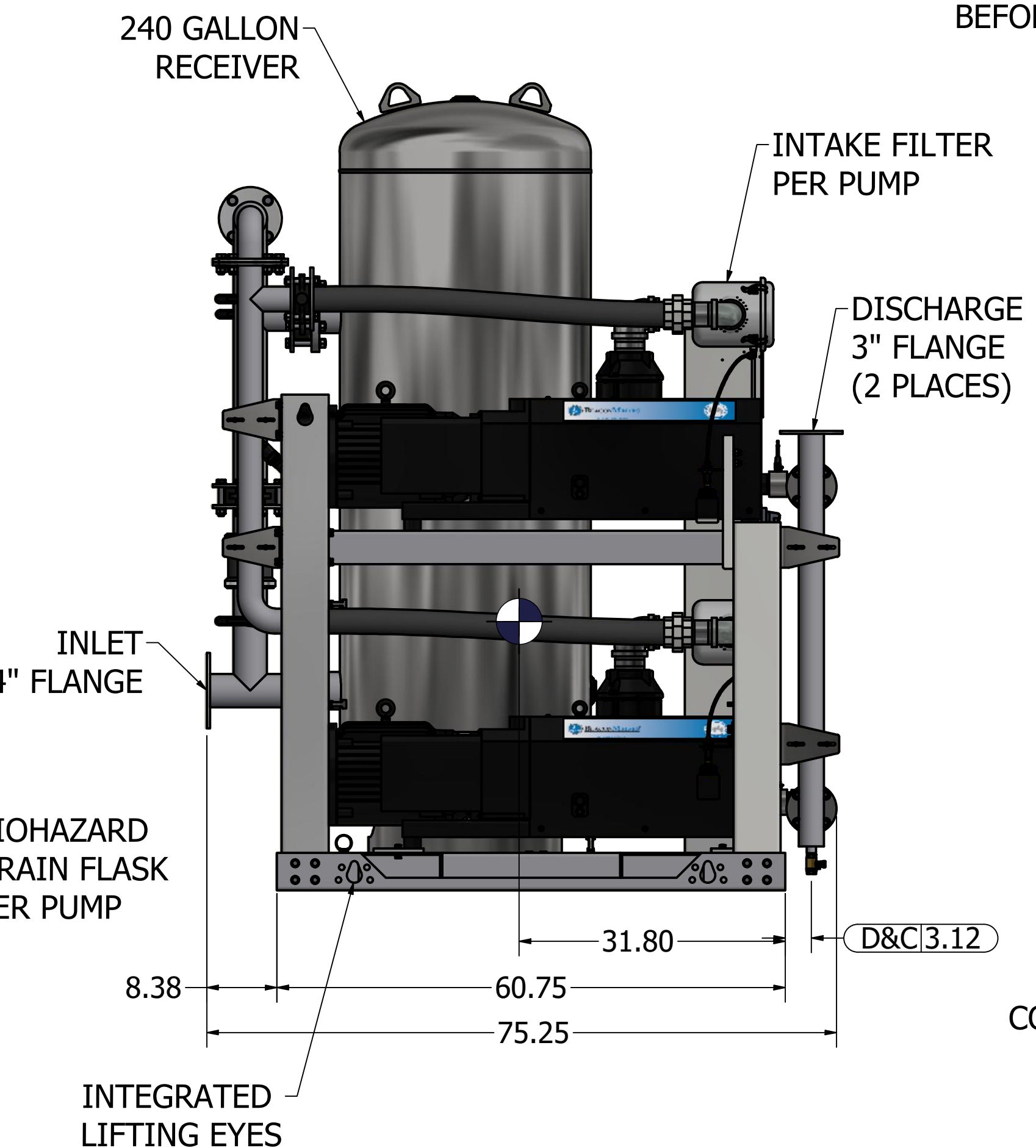
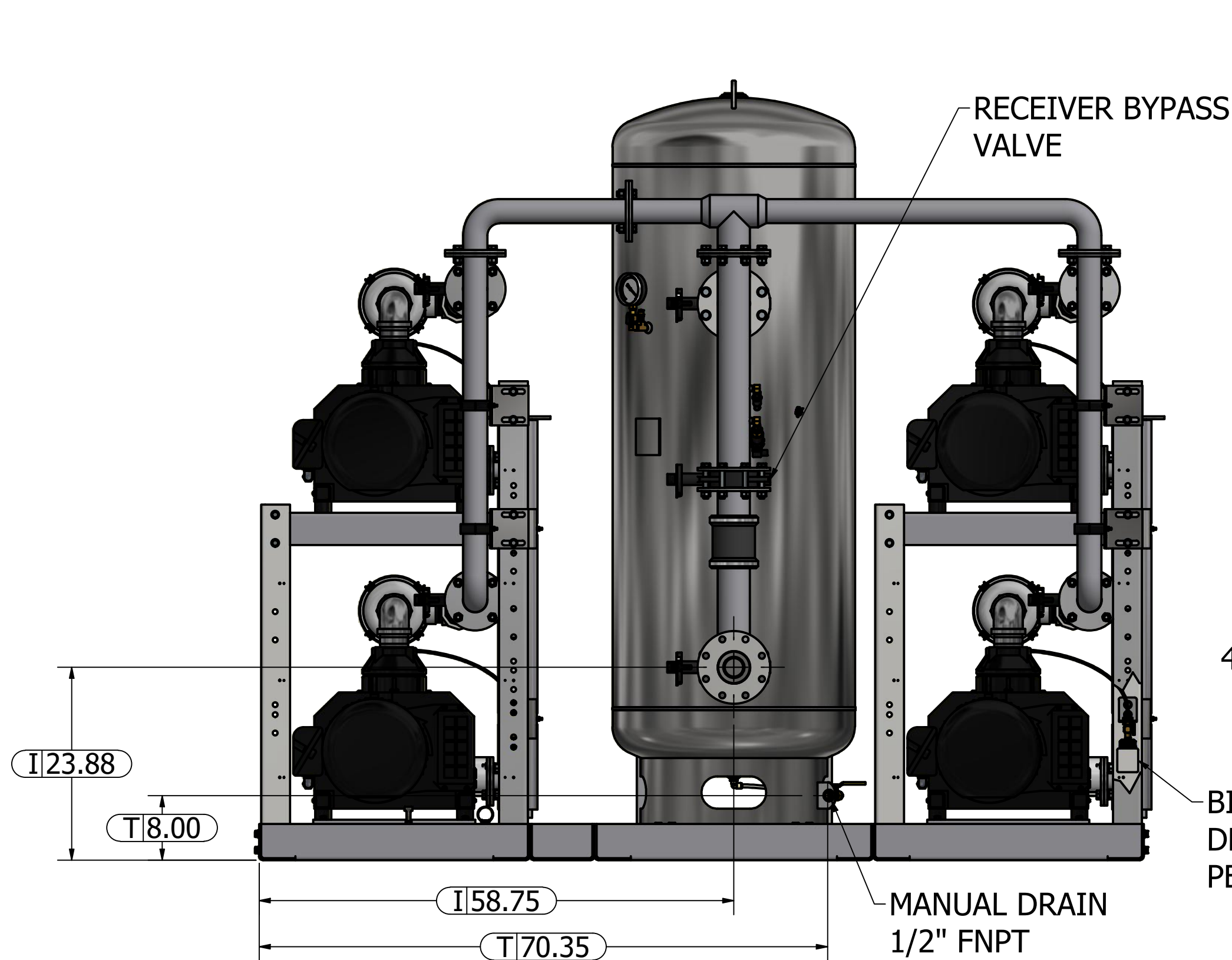
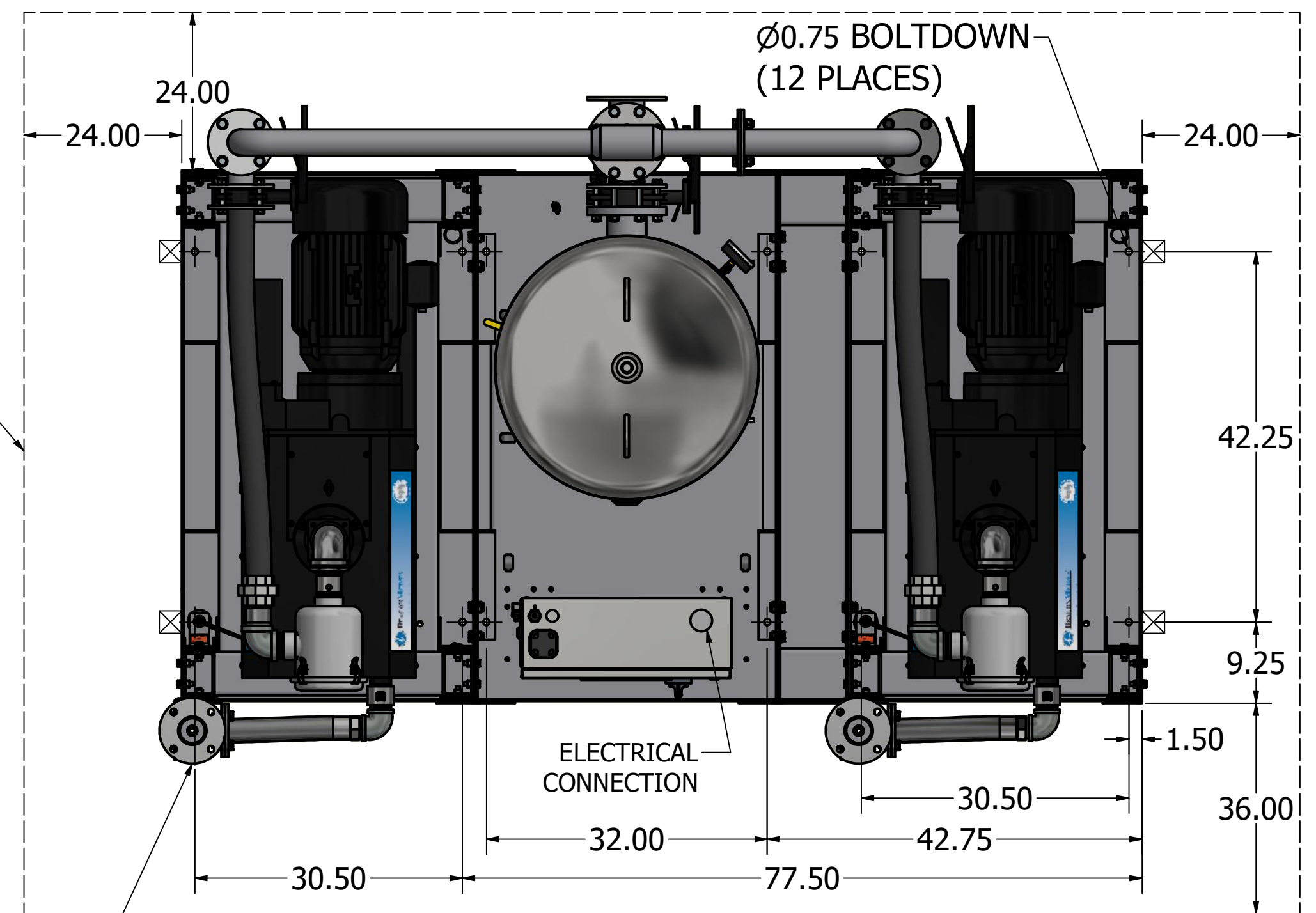

Revised: APS	Date: 1/24/2023	Drawn: JWO	Date: 2/10/2014
		This drawing and the information contained herein remain the property of BeaconMedaes and may not be used for other than the purpose for which it is loaned without the expressed written permission from BeaconMedaes Engineering.	
Description: GENERAL ASSEMBLY 15HP QX CLAW VAC SPC 240G RECEIVER		Part Number: 4107 8549 17	
DN: HOP220669		Rev: 03	
Sheet 1 of 1		DO NOT SCALE THIS DOCUMENT	