

Notes:

- DISCHARGE MUFFLERS WILL BE SHIPPED LOOSE.
- SYSTEM WEIGHT: 7,021.5 LBS. (INCLUDES FUTURE EXPANSION PUMP)
- ☒ INDICATES LIFTING POINT.
- ⊙ DENOTES CENTER OF GRAVITY. (INCLUDES FUTURE EXPANSION PUMP)

SYSTEM CONNECTIONS	
ID	DESCRIPTION
I	INLET LOCATION
D	DISCHARGE LOCATION
T	TANK DRAIN LOCATION
C	CONDENSATE DRAIN LOCATION

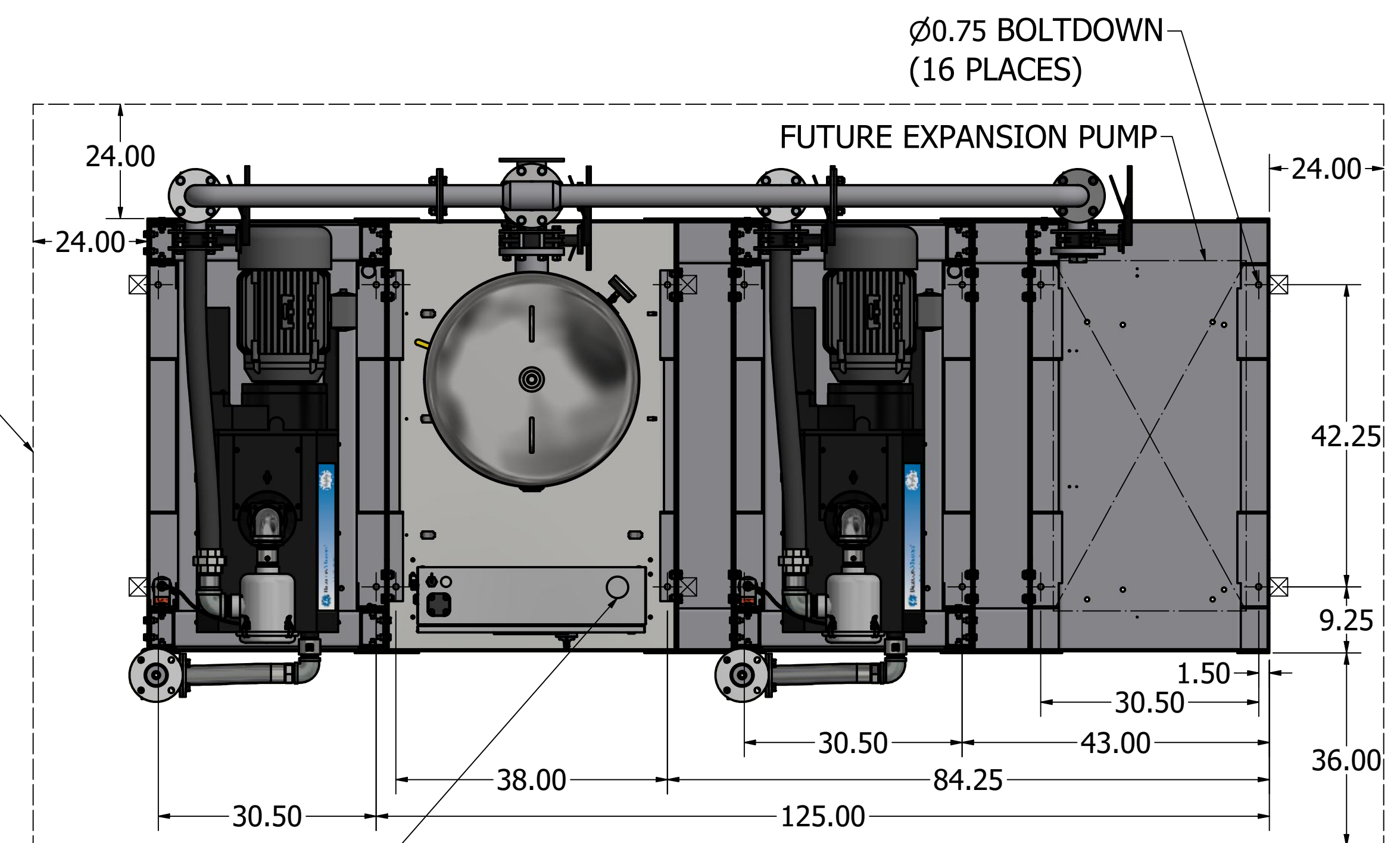

MINIMUM CLEARANCE FOR MAINTENANCE & VENTILATION

ELECTRICAL CONNECTION

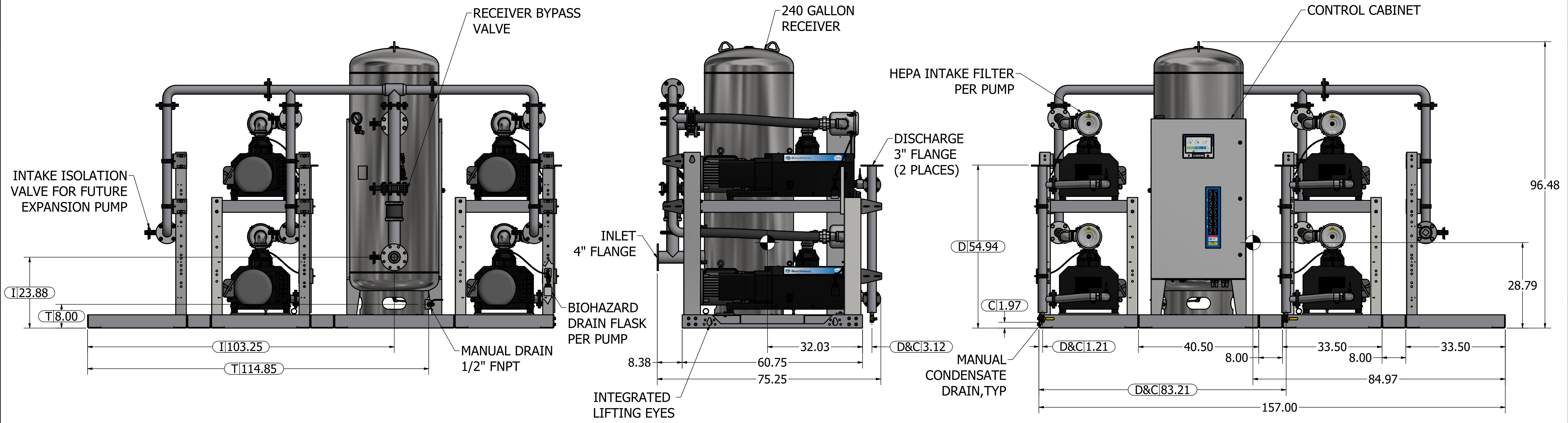

Revised: a00551998	Date: 3/28/2023	Drawn: JWO	Date: 1/13/2014
		This drawing and the information contained therein remain the property of BeaconMedaes and may not be used for other than the purpose for which it is loaned without the expressed written permission from BeaconMedaes Engineering.	
Description: GENERAL ASSEMBLY 15HP QX-EXP-PX CLAW VAC SPC 240G RECEIVER		Part Number: 4107 8549 55 DN: HOP230841 Rev: 03 Sheet 1 of 1	