

Notes:

1. MAIN DISCONNECT PROVIDED BY OTHER.
2. FIELD WIRING TO BE COPPER RATED FOR 75°C MINIMUM.
3. - - - - - INDICATES FIELD WIRING OUTSIDE OF CABINET.
4. AUXILIARY CONTACTS LIST ON SHEET 4.
5. THE AMPACITY OF CONDUCTORS SUPPLYING THE CONTROL PANEL TO BE ROUNDED UP TO THE NEXT SIZE LARGER STANDARD WIRE GAUGE.
6. MOP VALUES TO BE ROUNDED DOWN TO THE NEAREST STANDARD RATING OF THE OVERCURRENT PROTECTION DEVICE.
7. SHORT CIRCUIT CURRENT RATING (SCCR): 65 kA

MINIMUM CIRCUIT AMPACITY (MCA)

SYSTEM HP	208 V	230 V	380 V	460 V
10 HP	166.1 AMPS	150.9 AMPS	97.6 AMPS	76.1 AMPS
15 HP	246.9 AMPS	224.4 AMPS	144.9 AMPS	112.8 AMPS

MAXIMUM OVERCURRENT PROTECTION (MOP)

SYSTEM HP	208 V	230 V	380 V	460 V
10 HP	192.5 AMPS	175.0 AMPS	112.5 AMPS	87.5 AMPS
15 HP	288.8 AMPS	262.5 AMPS	168.8 AMPS	131.3 AMPS

PENTAPLEX SYSTEM FULL LOAD AMPERES

SYSTEM HP	208 V	230 V	380V/50Hz	460 V
10 HP	131.5 AMPS	123.2 AMPS	69.5 AMPS	62.1 AMPS
15 HP	197.0 AMPS	178.2 AMPS	105.0 AMPS	89.6 AMPS

INDIVIDUAL FULL LOAD AMPERES

SYSTEM HP	208 V	230 V	380V/50Hz	460 V
10 HP	25.6 AMPS	24.0 AMPS	13.4 AMPS	12.0 AMPS
15 HP	38.7 AMPS	35.0 AMPS	20.5 AMPS	17.5 AMPS

FUSE SELECTION CHART (MAX FUSE SIZES SHOWN)

SYSTEM HP	FUSES	208 V	230 V	380 V	460 V
ALL	F1/F2/F4/F5 F7/F8/F10 F11/F13/F14	6.0 AMPS	6.0 AMPS	6.0 AMPS	6.0 AMPS
	F3/F6/F9 F12/F15	---	---	6.0 AMPS	6.0 AMPS
	F21-F25	4.0 AMPS	4.0 AMPS	4.0 AMPS	4.0 AMPS
	F31/F32 F33/F34	1.0 AMP	1.0 AMP	1.0 AMP	1.0 AMP
	F35	0.5 AMP	0.5 AMP	0.5 AMP	0.5 AMP

F1-F15 ARE LITTELFUSE KLDK 600V TYPE  
F21-F25/F31-F35 ARE LITTELFUSE 2AG 250V TYPE

DEFAULT PUMP PSI SETTINGS

PUMP SEQUENCE	PSI
LEAD CUT-OFF	140
LAG CUT-ON	120

BACKUP PRESSURE SWT SETTINGS

BPS-1 CUT-OFF	PSI
BPS-1 CUT-ON	105

PUMP/DRYER PCB JUMPER/SWT SETTINGS

JPR/SWT	POSITION
JP1	1-2
S1	A (AUTO)

AUTO OPERATION:

DURING NORMAL OPERATION, THE MASTER PCB WILL SIGNAL THE LEAD COMPRESSOR TO START WHEN THE PRESSURE FALLS BELOW THE SET-POINT FOR THE LEAD PUMP. IF ONE PUMP CAN CARRY THE LOAD, THE PRESSURE WILL RISE TO 140 PSI. THE MASTER PCB WILL THEN SIGNAL THE PUMP PCB TO TURN OFF THE LEAD COMPRESSOR. WHEN THE SYSTEM PRESSURE DROPS AGAIN BELOW THE LEAD SET-POINT, THE MASTER PCB WILL SEQUENCE THE LEAD ROLE TO THE NEXT COMPRESSOR AND IT WILL START. IF ANY LEAD COMPRESSOR RUNS FOR MORE THAN 17 MINUTES AND CANNOT REACH 140 PSI, THE MASTER PCB WILL TURN OFF THE COMPRESSOR THAT IS RUNNING AND SEQUENCE TO THE NEXT COMPRESSOR.

PUMP PCB S1 POSITION:

POSITION (A) - AUTO (DEFAULT):

THE PUMP WILL OPERATE NORMALLY AS DESCRIBED ABOVE IN "AUTO OPERATION".

POSITION (X) - OFF:

THE PUMP IS DISABLED FROM RUNNING.

POSITION (O) - MANUAL:

THE PUMP WILL START AND STOP ON THE BACK UP PRESSURE SWITCH (BPS-1).

PCB FAULT:

IF A PUMP PCB ETHERNET FAULT OR A TRANSDUCER FAULT OCCURS, THE PUMP PCB WILL AUTOMATICALLY SWITCH TO MANUAL MODE. COMPRESSORS WILL START WHEN BPS-1 (BACKUP PRESSURE SWITCH) CLOSSES AND STOP WHEN IT OPENS. COMPRESSORS WILL NOT SEQUENCE IN THIS CONDITION AND CAN OPERATE UNTIL THE ETHERNET OR TRANSDUCER FAULT IS REPAIRED.

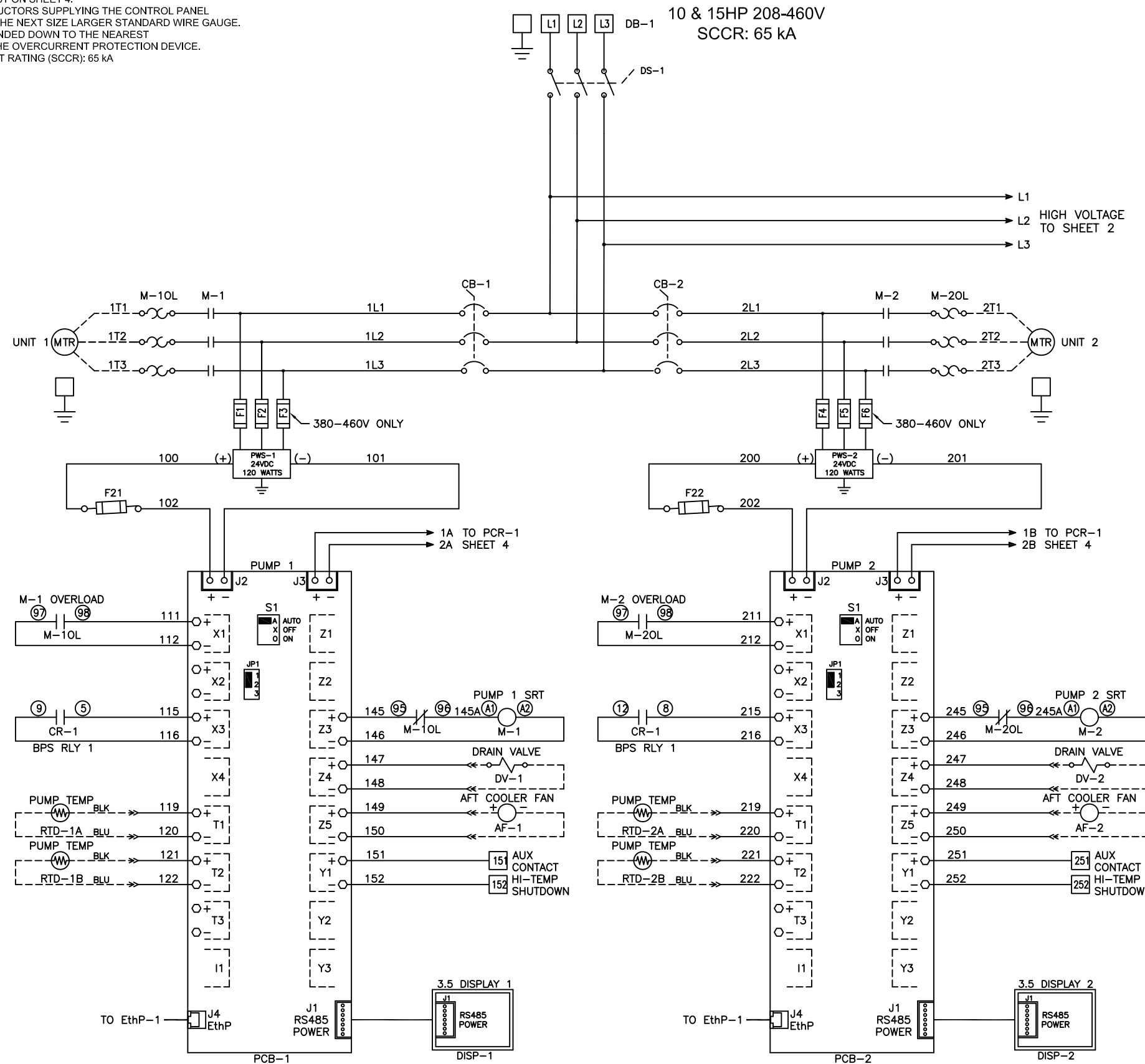

Revised: BM	Date: 01/19/22	Drawn: MDB	Date: 10/30/18
		This drawing and the information contained therein remain the property of BeaconMedias and may not be used for other than the purpose for which it is loaned without the expressed written permission from BeaconMedias Engineering.	
Description: DWG WIRING CONTROL PX LAB SCROLL 10-15HP 208-460/3/50-60, 65KA		Part Number: 4107 8568 36	
DN: HOP211246		Rev: 02	
Sheet 1 of 4		DO NOT SCALE THIS DOCUMENT	

Notes:

1. FIELD WIRING TO BE COPPER RATED FOR 75°C MINIMUM.

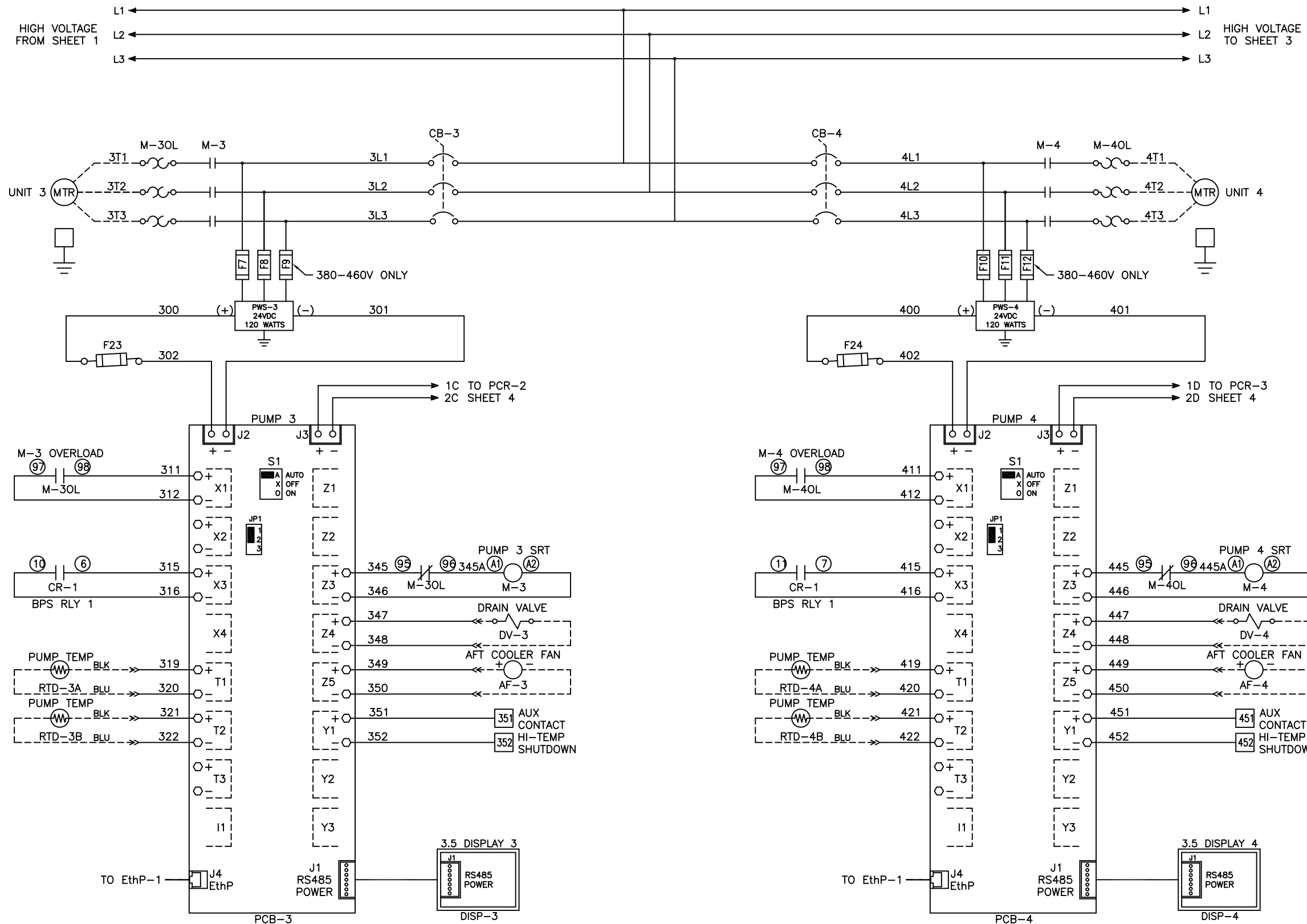

Revised: BM	Date: 01/19/22	Drawn: MDB	Date: 10/30/18
			Scale: NTS
Description: DWG WIRING CONTROL PX LAB SCROLL 10-15HP 208-460/3/50-60, 65KA			Part Number: 4107 8568 36 Rev: 02
Sheet 2 of 4			DO NOT SCALE THIS DOCUMENT

Notes:

1. FIELD WIRING TO BE COPPER RATED FOR 75°C MINIMUM.

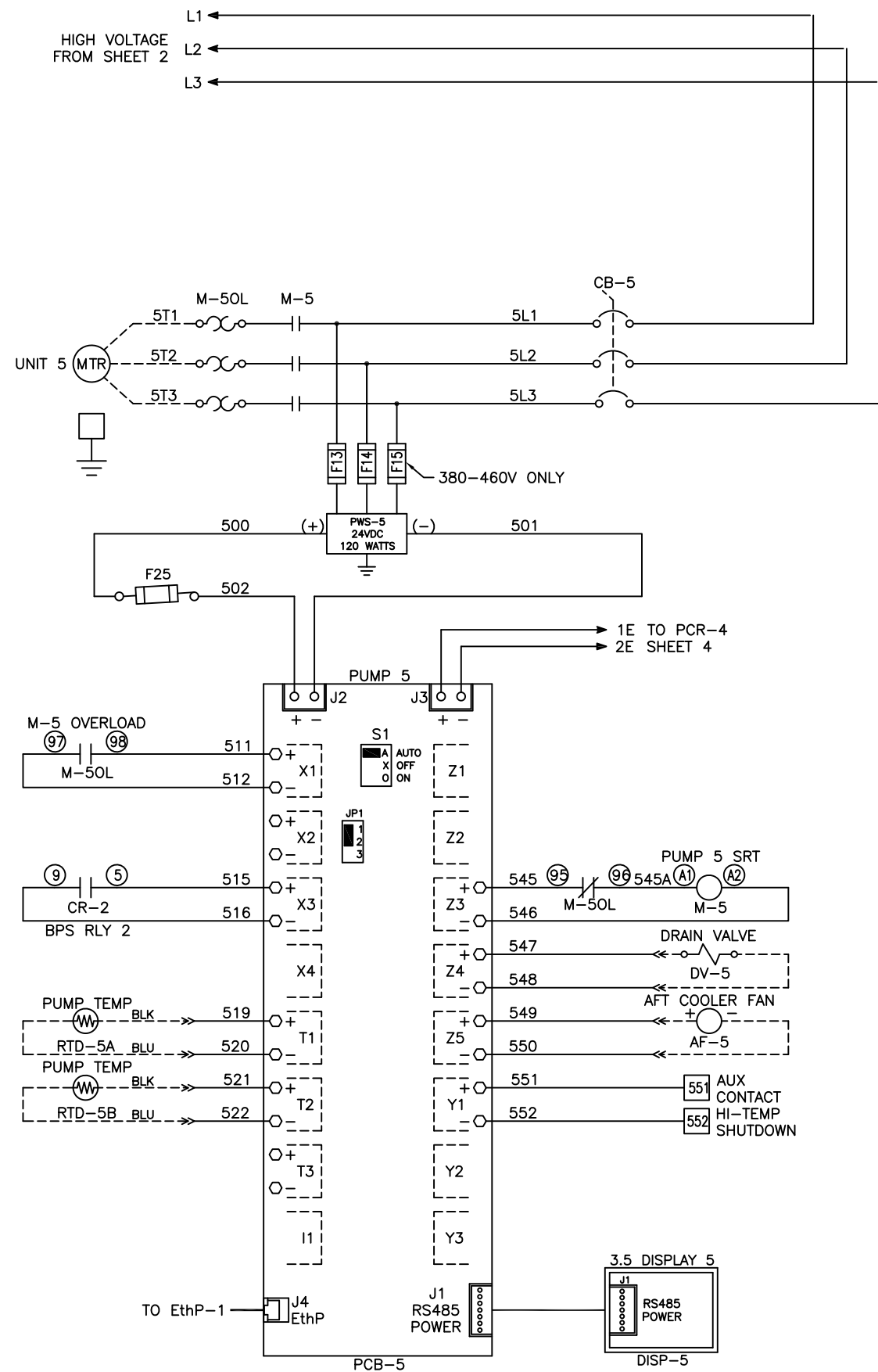

Revised: BM	Date: 01/19/22	Drawn: MDB	Date: 10/30/18
		<small>This drawing and the information contained thereon remain the property of BeaconMedes and may not be used for other than the purpose for which it is loaned without the expressed written permission from BeaconMedes Engineering.</small>	
Description: DWG WIRING CONTROL PX LAB SCROLL 10-15HP 208-460/3/50-60, 65KA		Part Number: 4107 8568 36 D	
Sheet 3 of 4		Scale: NTS Rev: 02 HOP211246 DO NOT SCALE THIS DOCUMENT	

Notes:  
 1. FIELD WIRING TO BE COPPER RATED FOR 75°C MINIMUM.

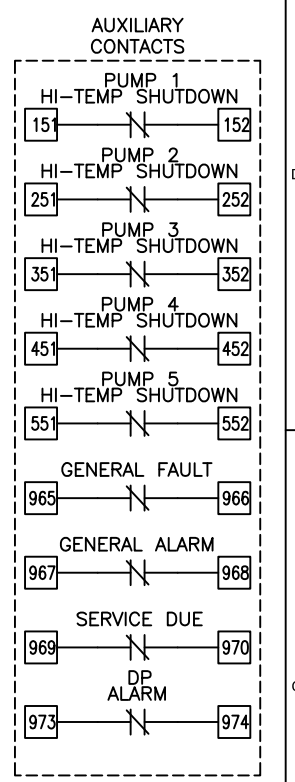
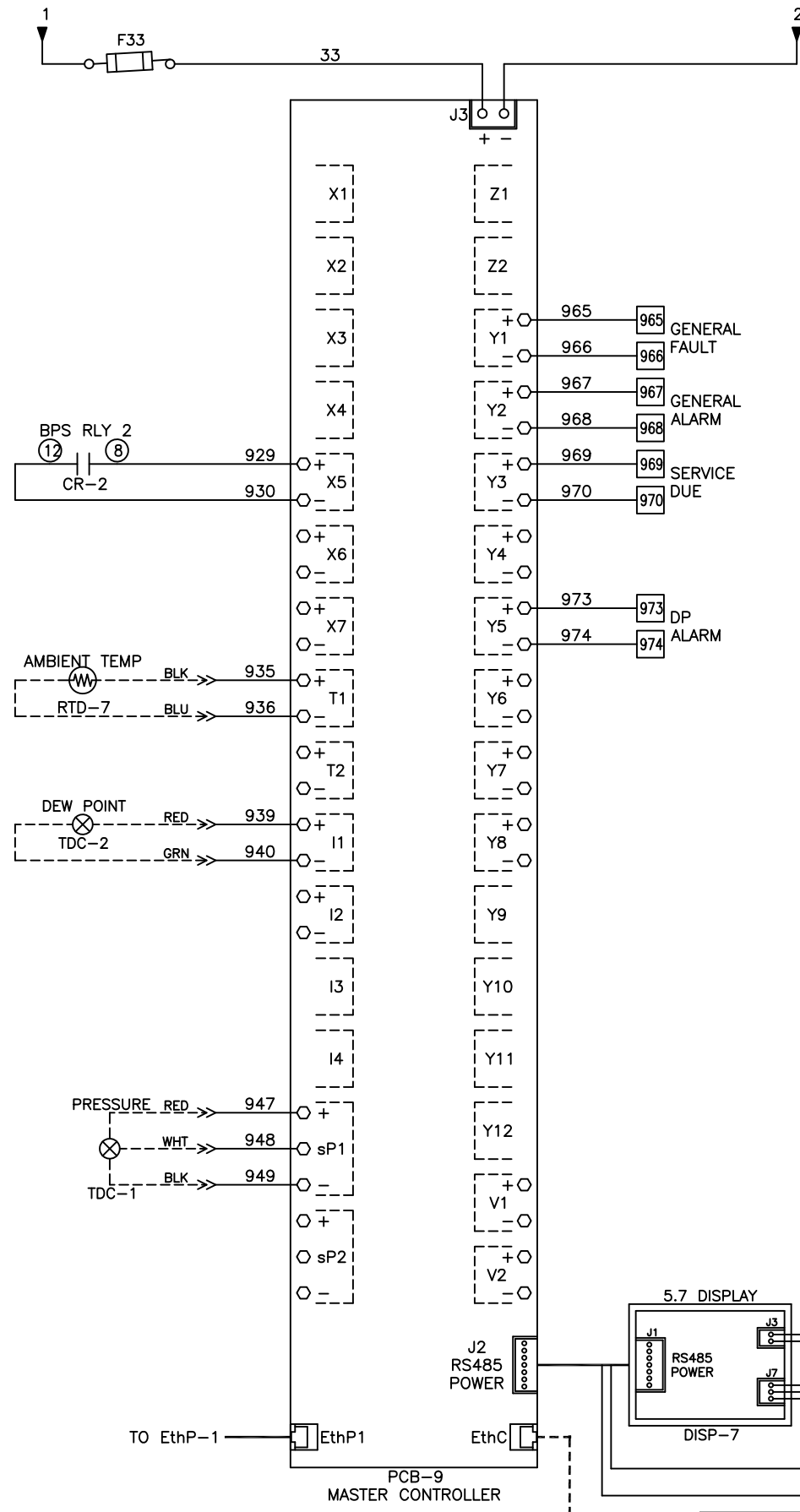
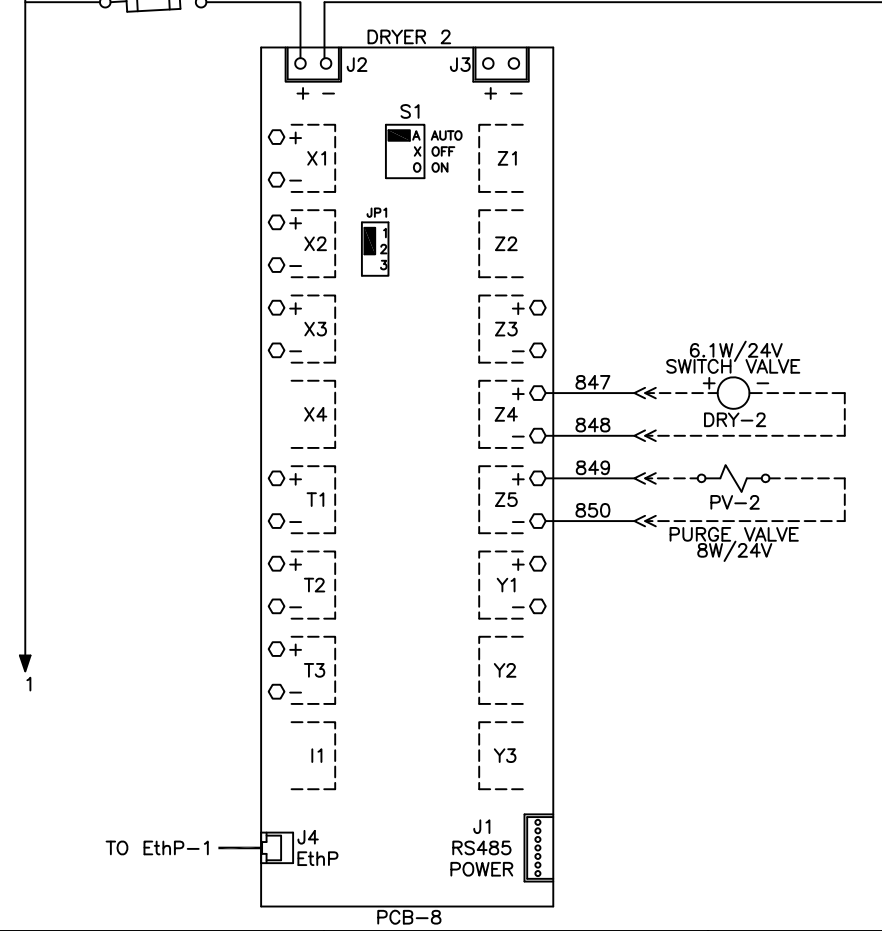
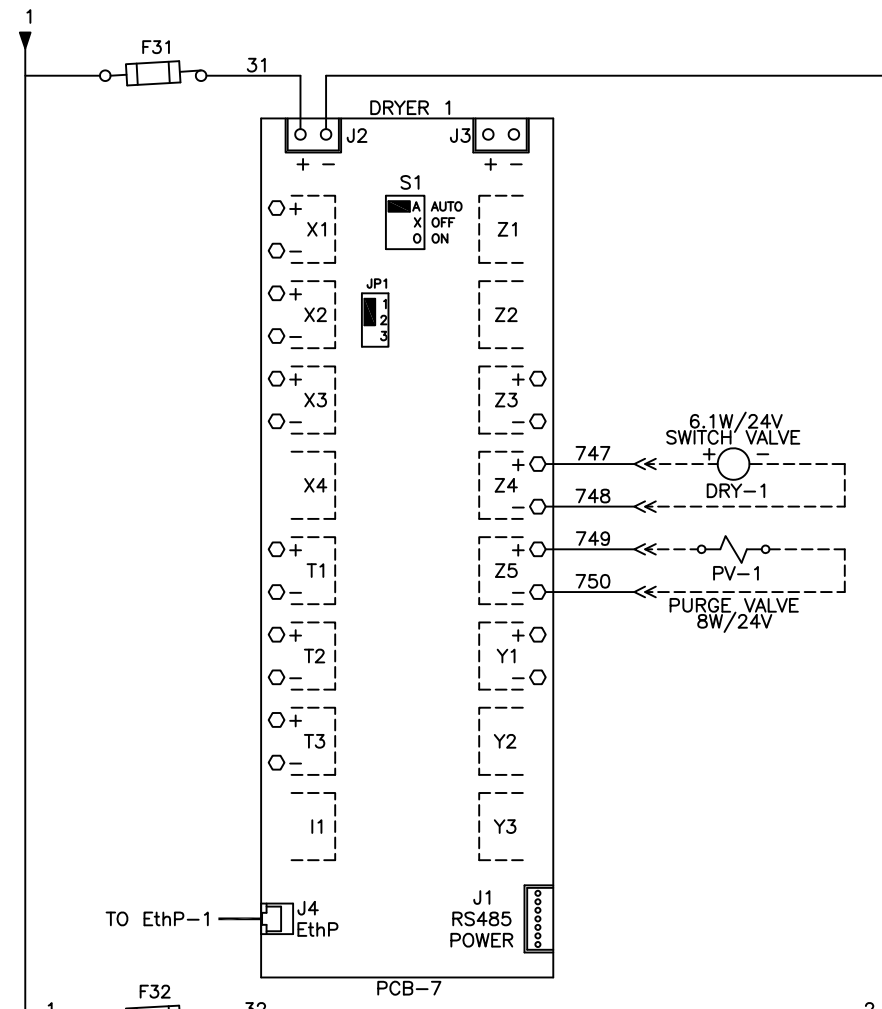
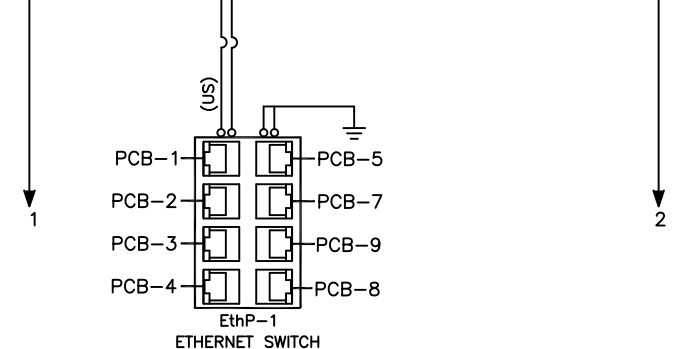
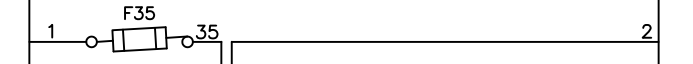
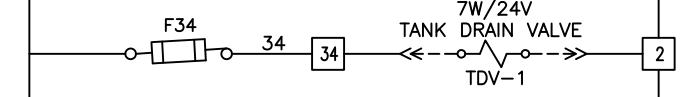
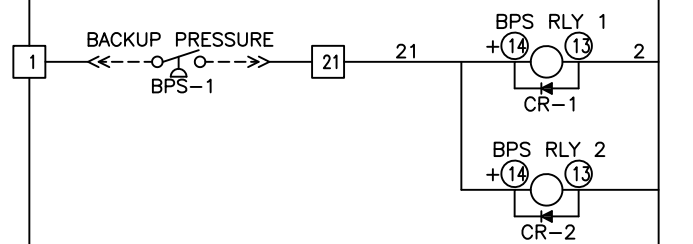
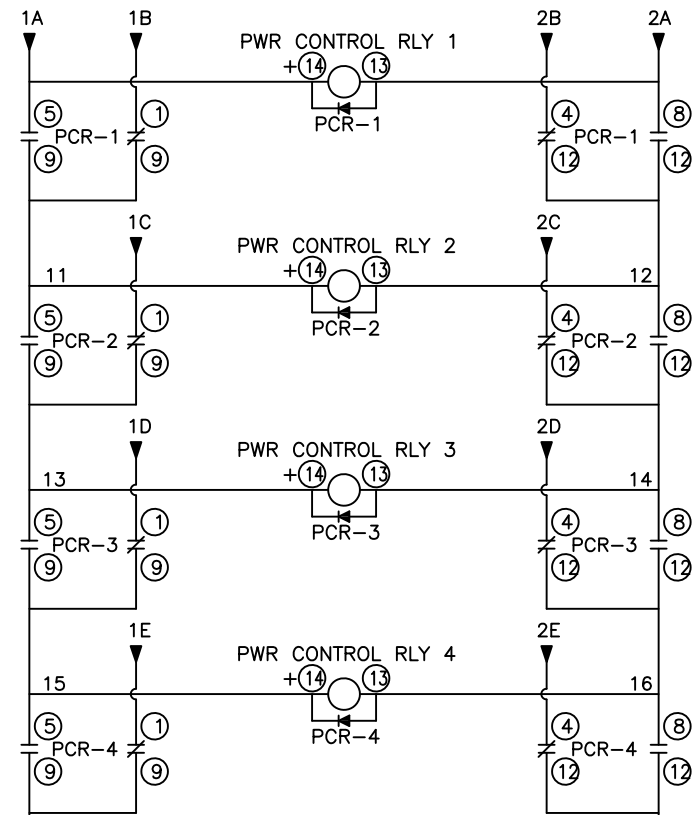

NOTE:  
 AUXILIARY CONTACTS  
 151-152, 251-252,  
 351-352, 451-452,  
 551-552, 965-970, &  
 973-974 ARE "CLASS 1  
 CONTROL CIRCUITS. USE  
 CLASS 1 CONDUCTORS."

AUX CONTACTS ARE RATED  
 0.7A<sub>dc</sub>/0.7A<sub>rms</sub> @ 24V  
 MAX. UNLESS OTHERWISE  
 NOTED.

AUX CONTACTS CLOSED  
 DURING NORMAL  
 OPERATION.

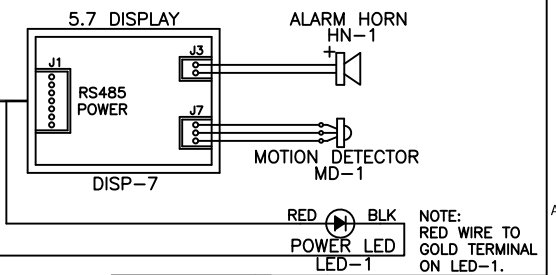

Revised: BM	Date: 01/19/22	Drawn: MDB	Date: 10/30/18
Description: DWG WIRING CONTROL PX LAB SCROLL 10-15HP 208-460/3/50-60, 65KA		Part Number: 4107 8568 36	Scale: NTS
Dwg No: HOP211246		Rev: 02	Sheet 4 of 4