

Notes:

- DISCHARGE MUFFLER WILL BE SHIPPED LOOSE.
- DX MODULE WEIGHT: 1,820 LBS
200G TANK WEIGHT: 618 LBS
- ⊠ INDICATES LIFTING POINT.
- DENOTES CENTER OF GRAVITY.

SYSTEM CONNECTIONS	
ID	DESCRIPTION
I	INLET LOCATION
D	DISCHARGE LOCATION
C	CONDENSATE DRAIN LOCATION
T	TANK DRAIN

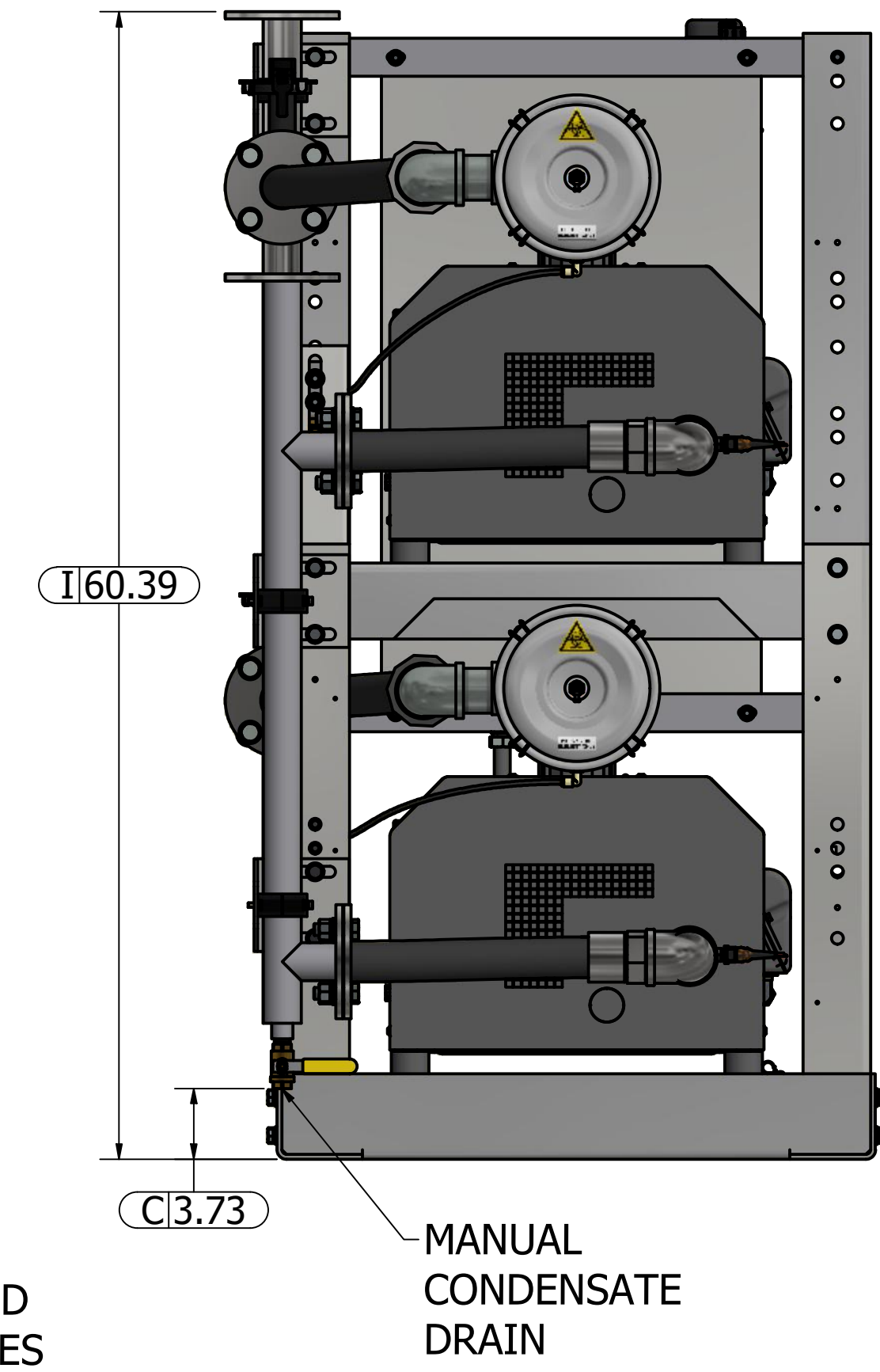
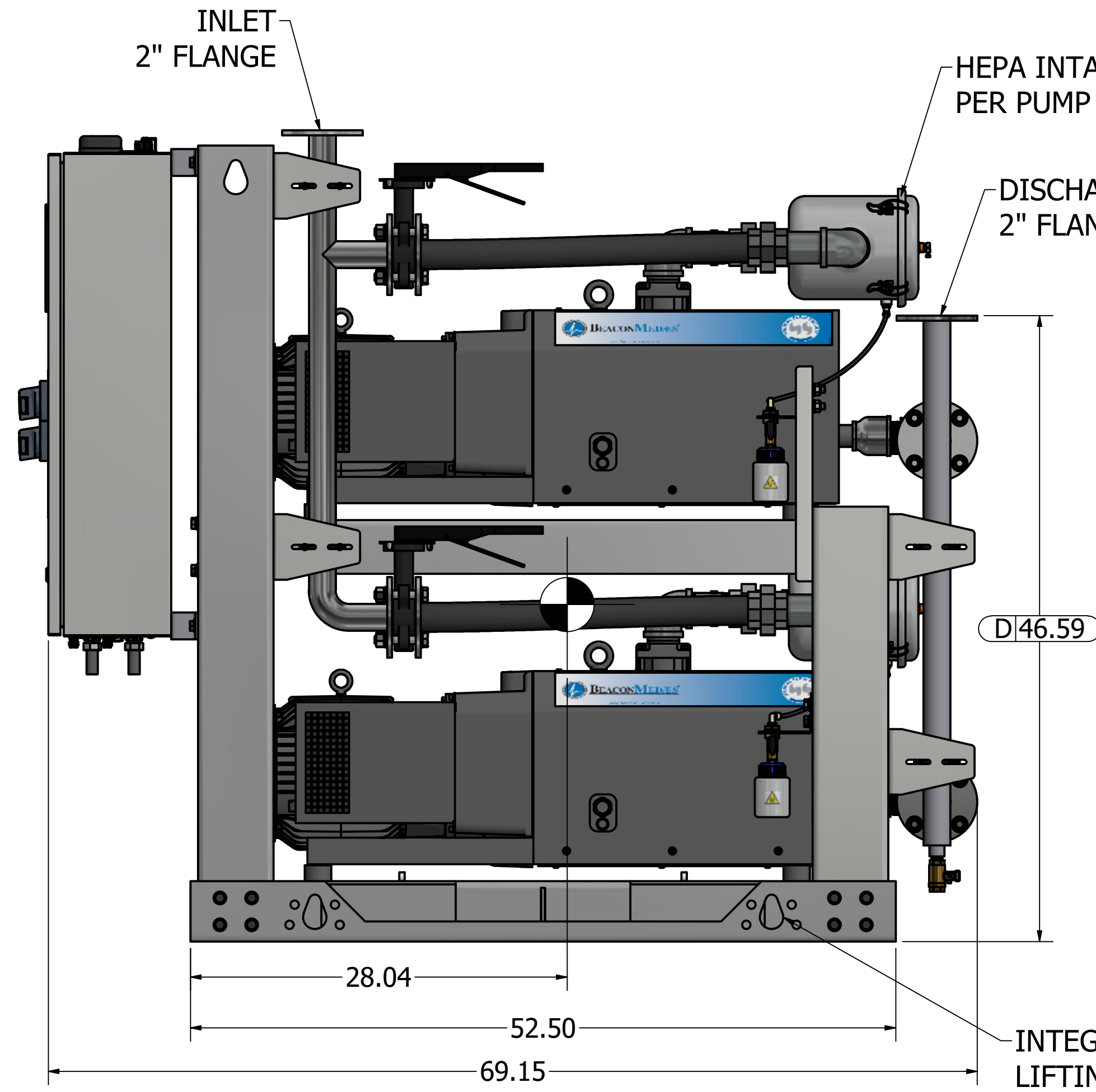
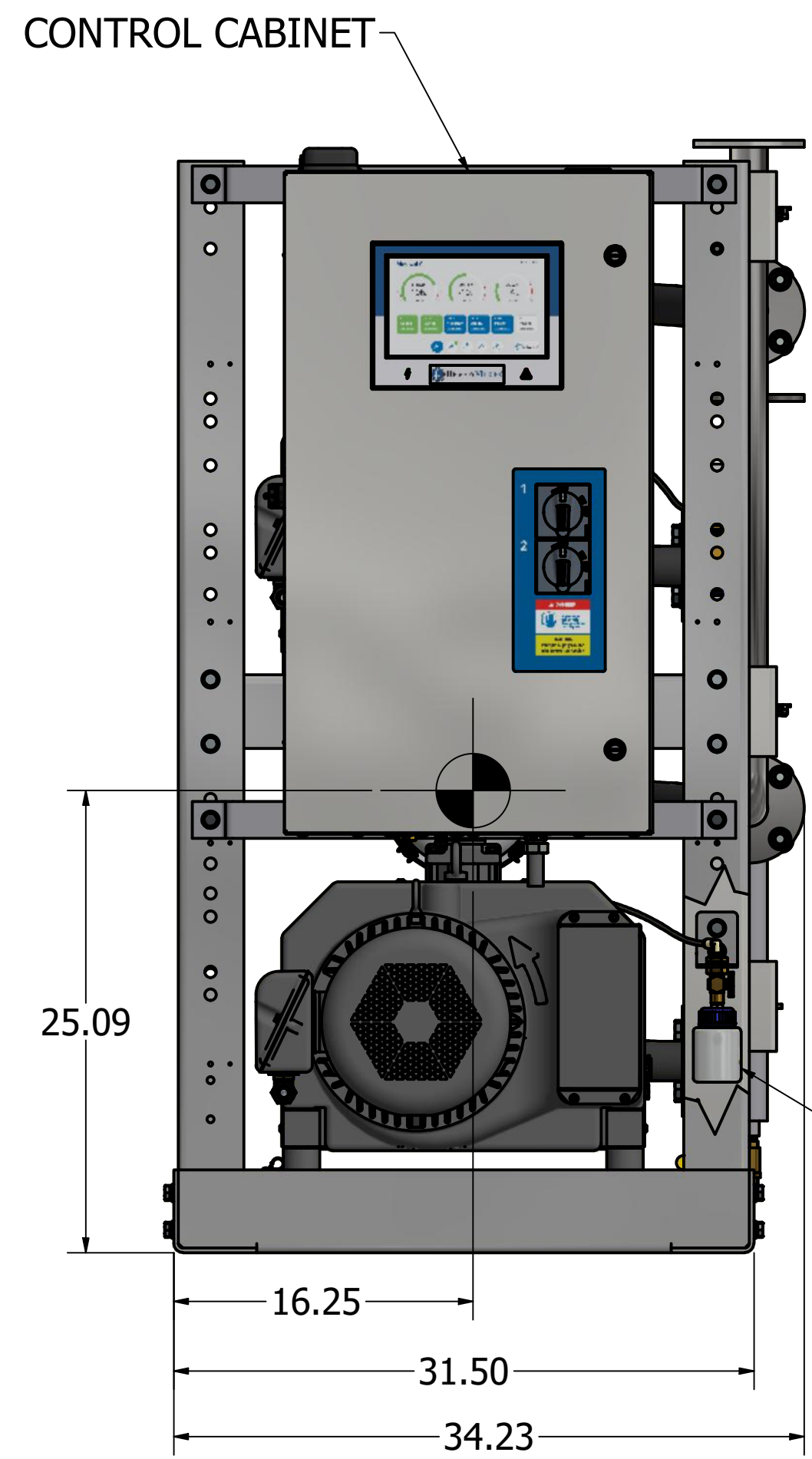
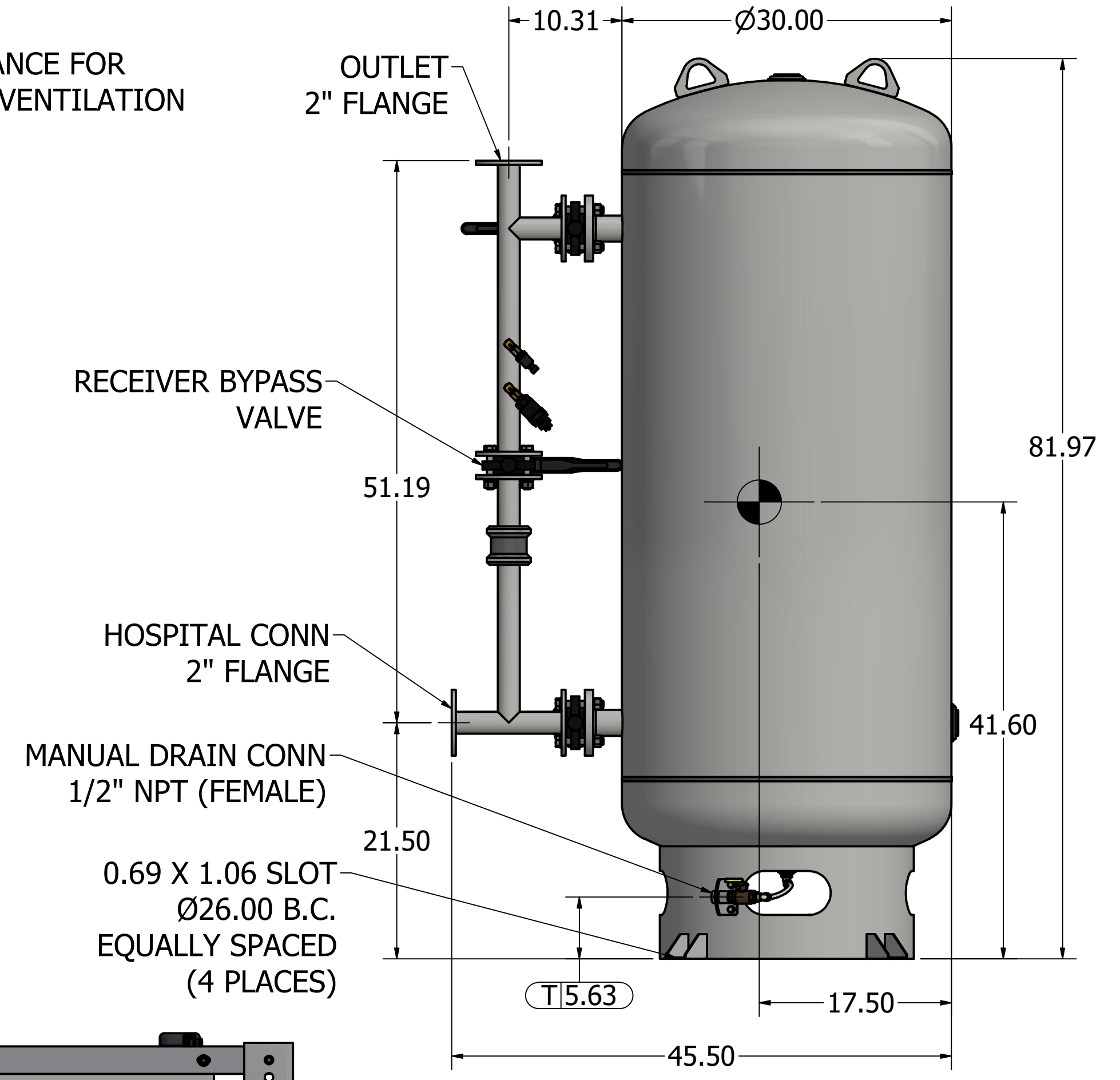
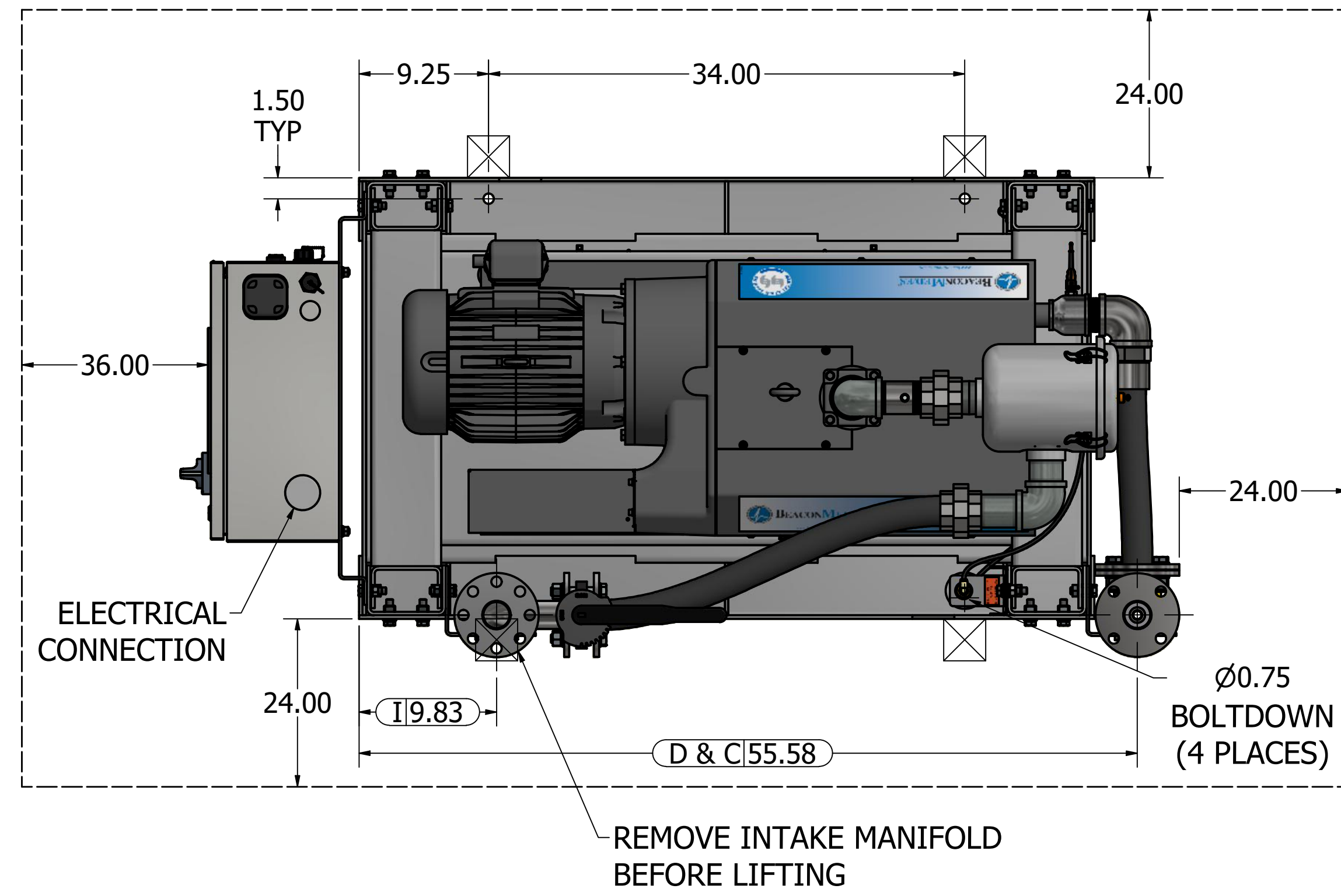

Revised: a00545201	Date: 3/20/2023	Drawn: JDY	Date: 11/1/2010
		This drawing and the information contained therein remain the property of BeaconMedaes and may not be used for other than the purpose for which it is loaned without the expressed written permission from BeaconMedaes Engineering.	
Description: GENERAL ASSEMBLY 8.7HP DX CLAW VAC MOD 200G RECEIVER STANDARD AND O2 ASSURED		Part Number: 4107 8513 14	
Sheet 1 of 1		Rev: 03 DO NOT SCALE THIS DOCUMENT	