

Notes:

- DISCHARGE MUFFLER WILL BE SHIPPED LOOSE.
- DX MODULE WEIGHT: 1,793 LBS  
200G TANK WEIGHT: 618 LBS
- ⊠ INDICATES LIFTING POINT.
- DENOTES CENTER OF GRAVITY.

SYSTEM CONNECTIONS	
ID	DESCRIPTION
I	INLET LOCATION
D	DISCHARGE LOCATION
C	CONDENSATE DRAIN LOCATION
T	TANK DRAIN

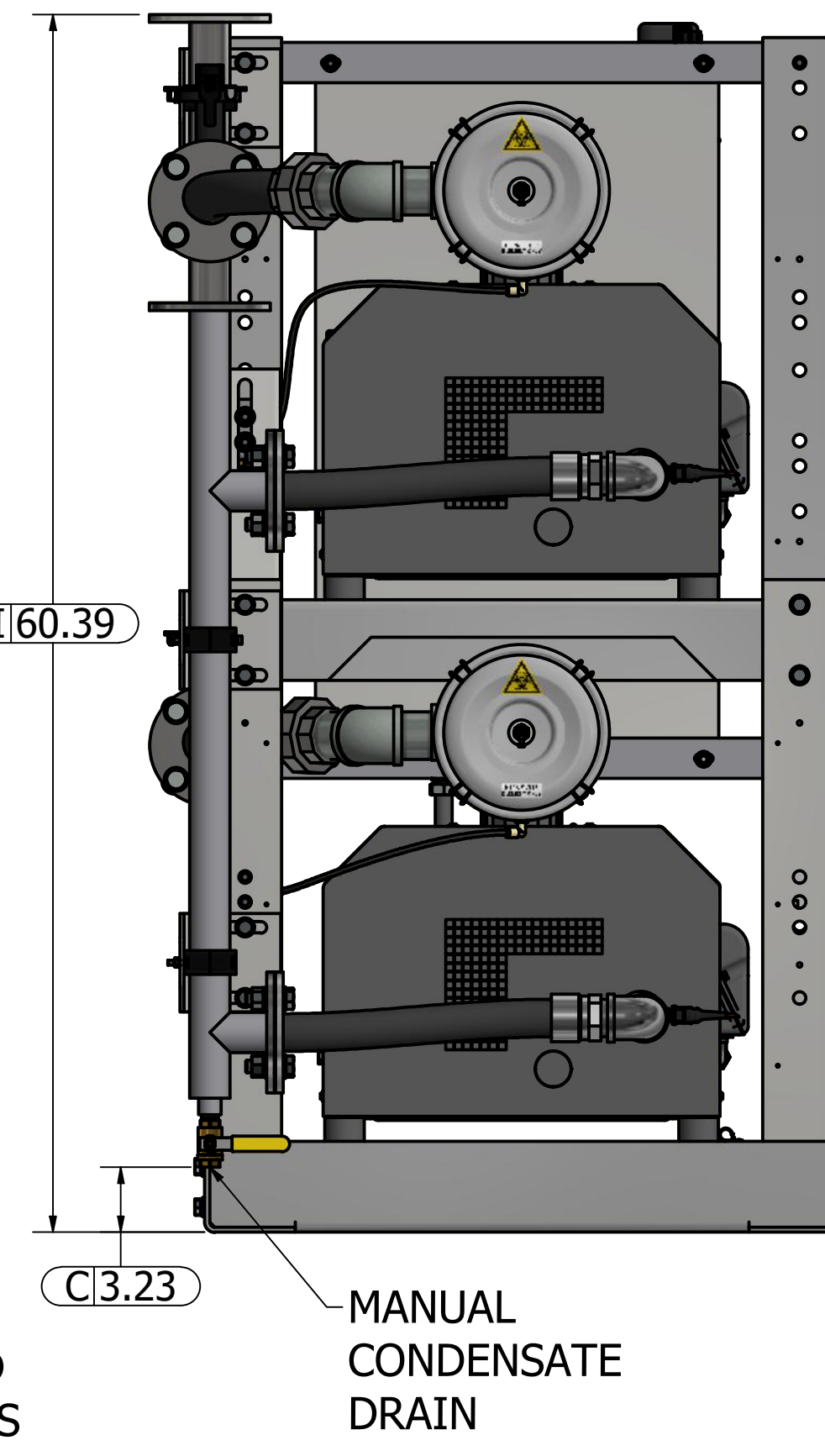
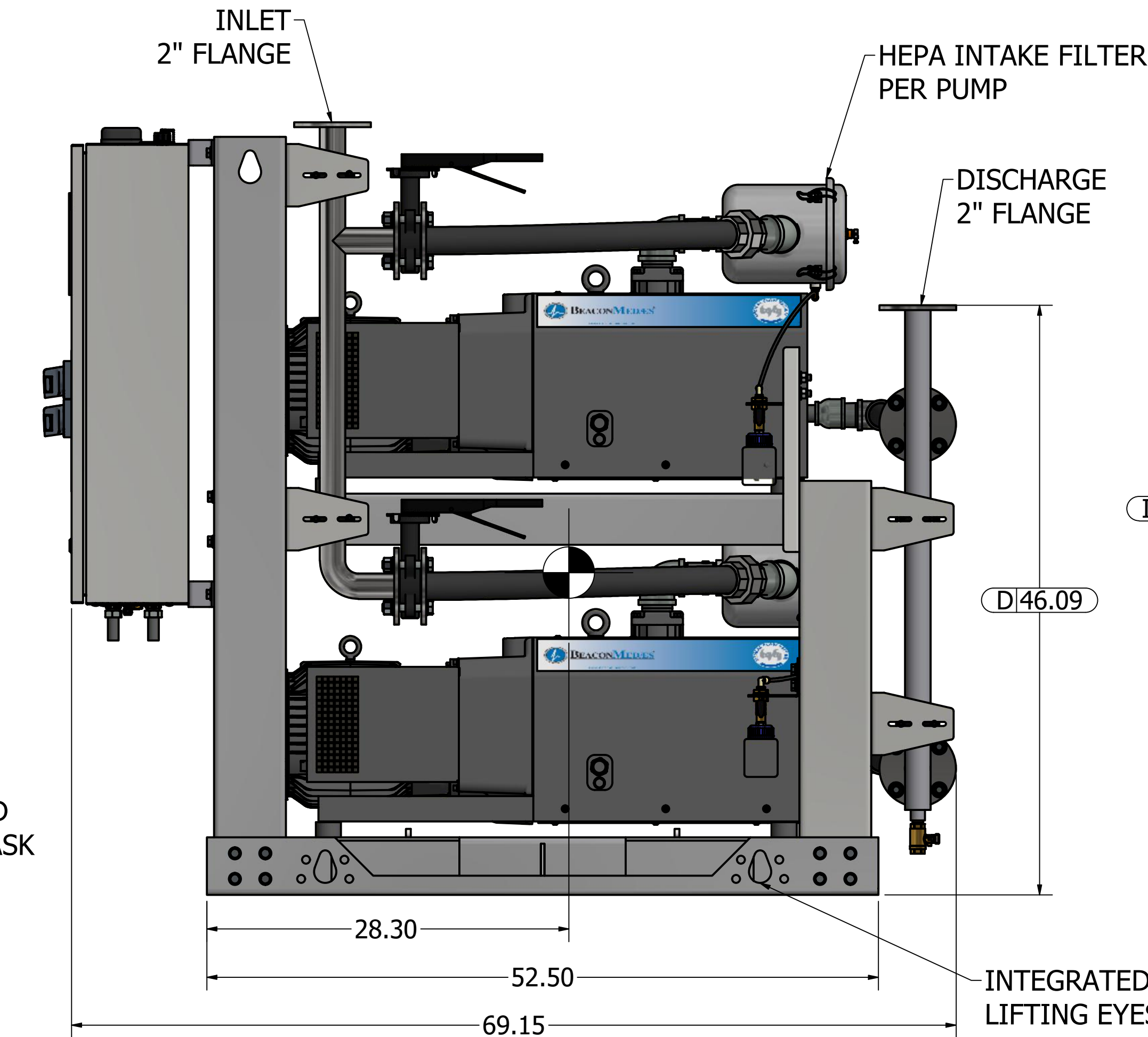
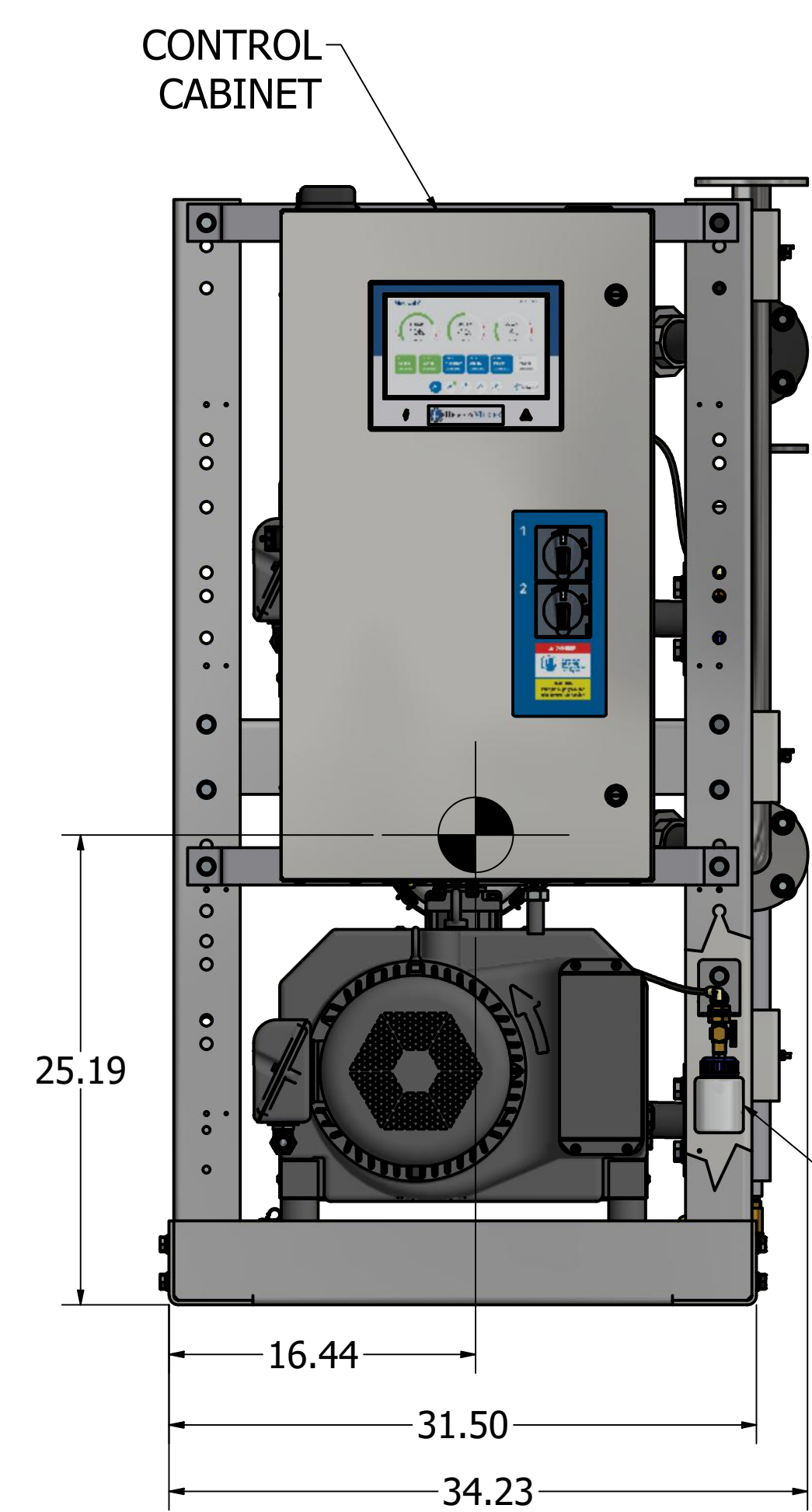
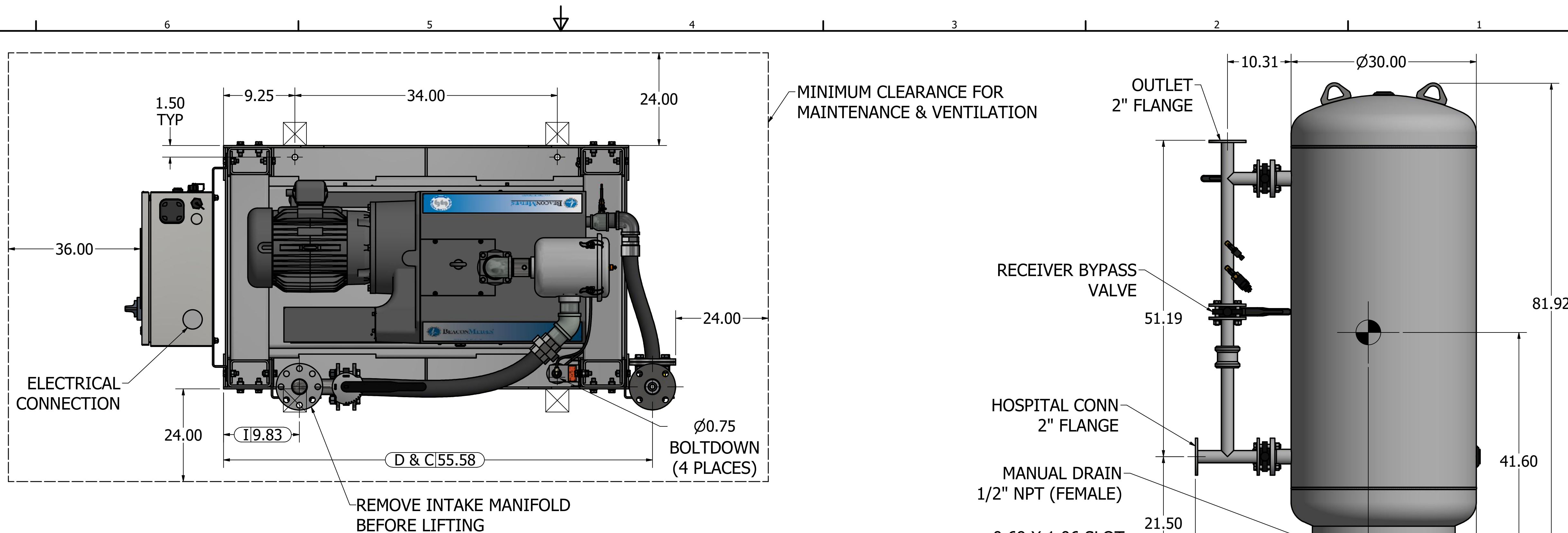

200 GAL VACUUM RECEIVER  
2" FLANGED CONNECTIONS  
(SCALE 1:10)

Revised: a00545201	Date: 3/16/2023	Drawn: MDB	Date: 1/11/2010
		This drawing and the information contained herein remain the property of BeaconMedes and may not be used for other than the purpose for which it is loaned without the expressed written permission from BeaconMedes Engineering.	
Description: GENERAL ASSEMBLY 6.4HP DX CLAW VAC MOD 200G RECEIVER STANDARD AND O2 ASSURED		Part Number: 4107 8513 08	
DN: HOP230841		Rev: 03	
Sheet 1 of 1		DO NOT SCALE THIS DOCUMENT	