

Notes:

- DISCHARGE MUFFLER WILL BE SHIPPED LOOSE.
- DX MODULE WEIGHT: 1,385 LBS
200G TANK WEIGHT: 618 LBS
- ☒ INDICATES LIFTING POINT.
- DENOTES CENTER OF GRAVITY.

SYSTEM CONNECTIONS	
ID	DESCRIPTION
I	INLET LOCATION
D	DISCHARGE LOCATION
C	CONDENSATE DRAIN LOCATION
T	TANK DRAIN

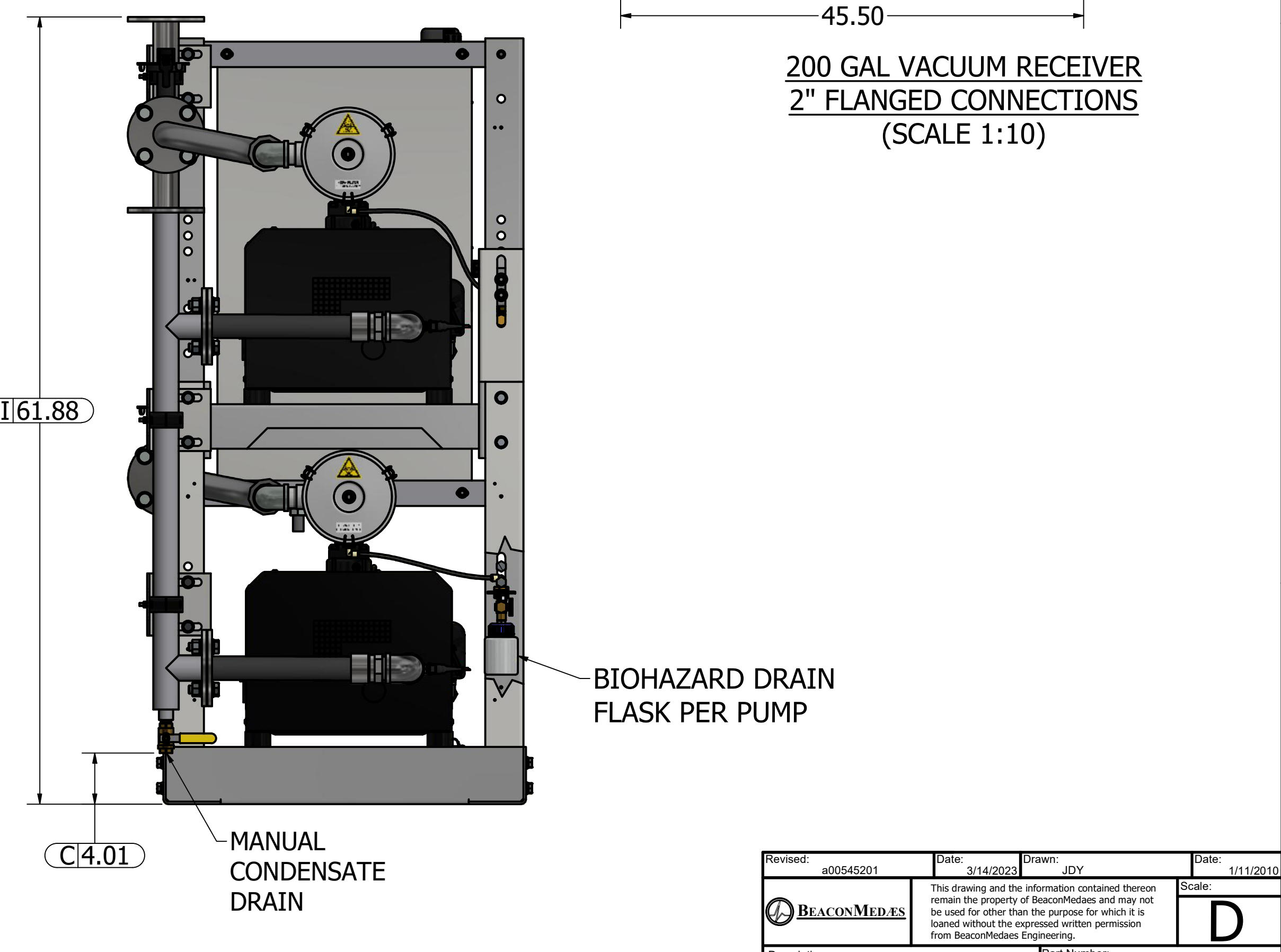
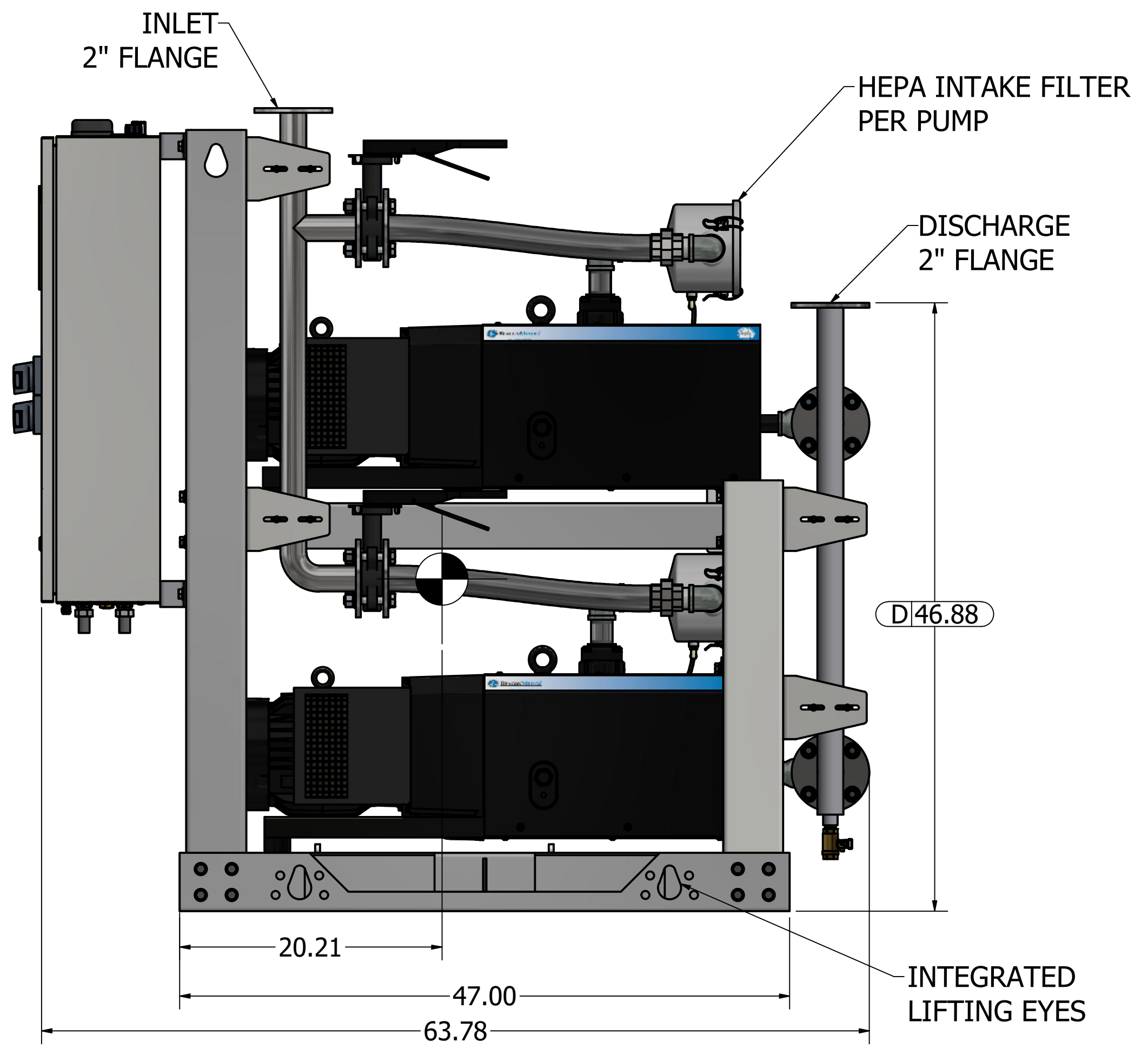
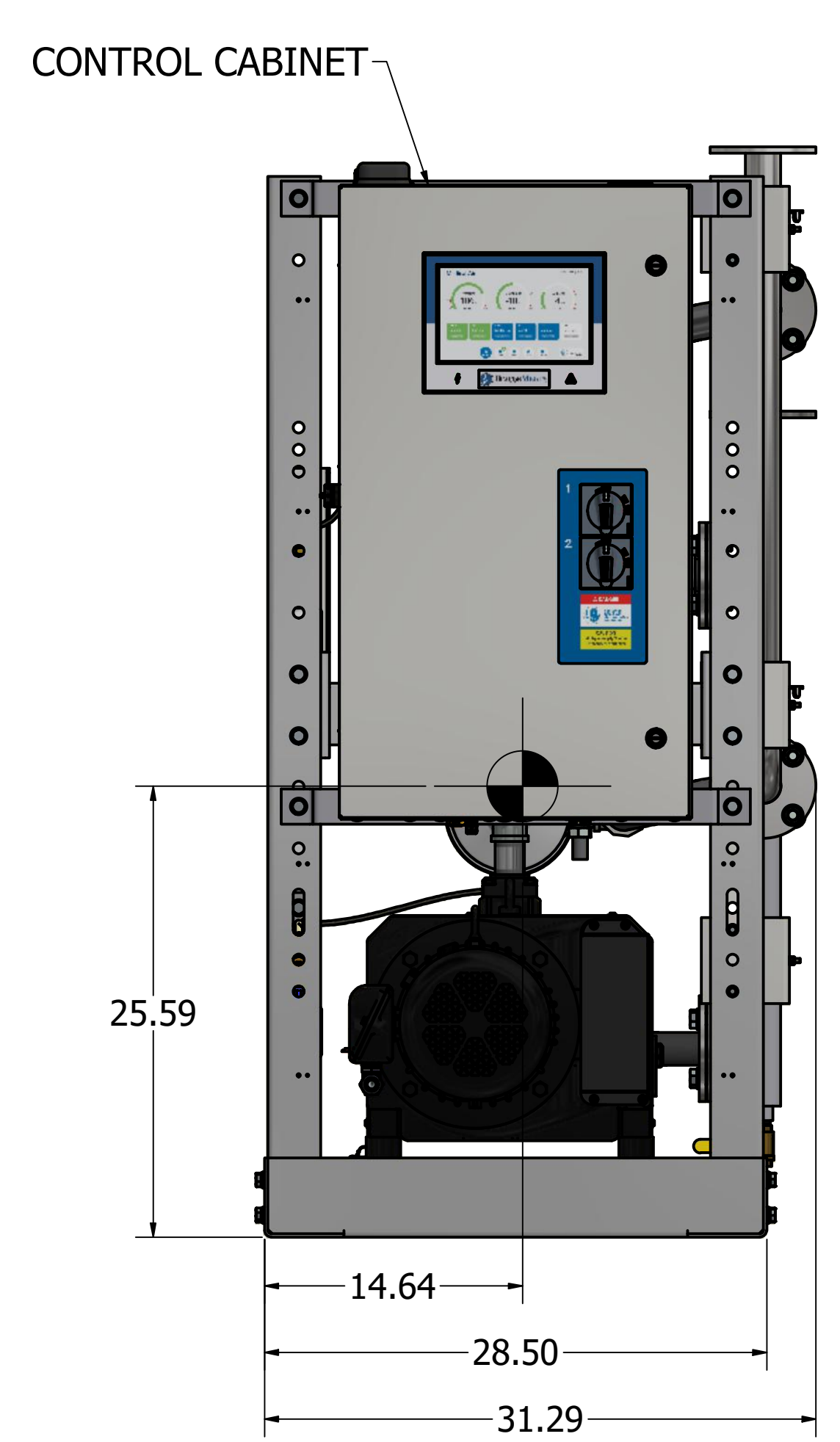
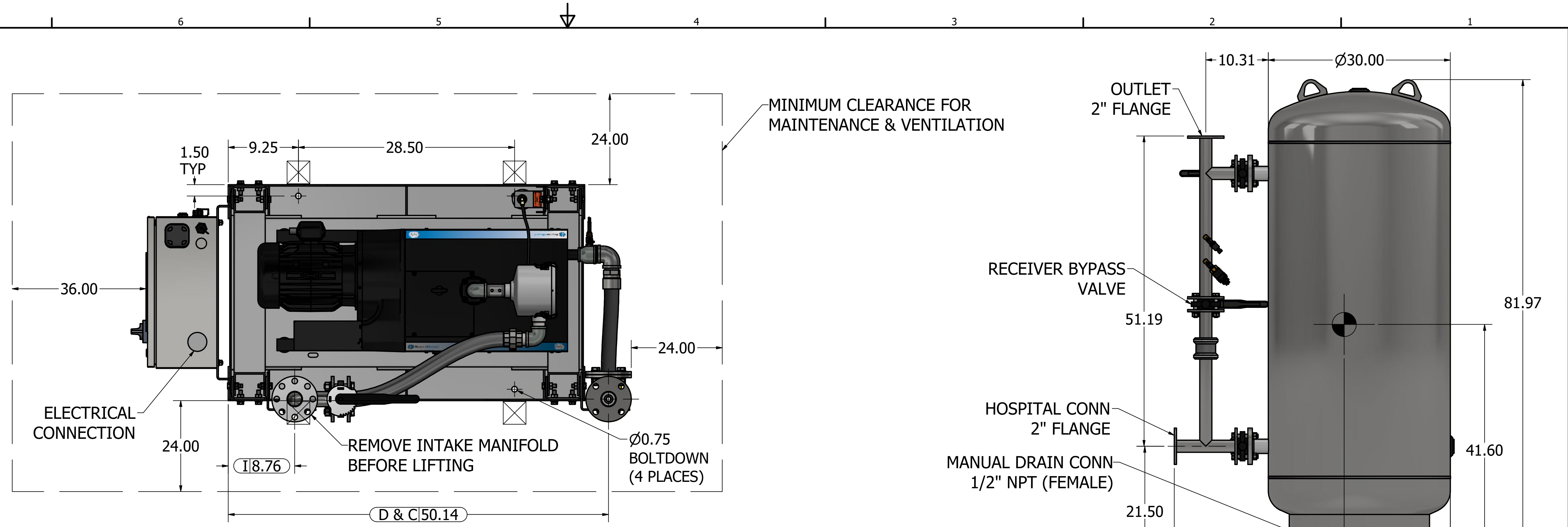

200 GAL VACUUM RECEIVER
2" FLANGED CONNECTIONS
(SCALE 1:10)

Revised: a00545201	Date: 3/14/2023	Drawn: JDY	Date: 1/11/2010
		This drawing and the information contained therein remain the property of BeaconMedaes and may not be used for other than the purpose for which it is loaned without the expressed written permission from BeaconMedaes Engineering.	
Description: GENERAL ASSEMBLY 5.4HP DX CLAW VAC MOD 200G RECEIVER STANDARD AND O2 ASSURED		Part Number: 4107 8513 05	
DN: HOP230841		Rev: 03	
Sheet 1 of 1		DO NOT SCALE THIS DOCUMENT	