

- Notes:
1. MAIN DISCONNECT PROVIDED BY OTHER.
 2. FIELD WIRING TO BE COPPER RATED FOR 75°C MINIMUM.
 3. - - - - - INDICATES FIELD WIRING OUTSIDE OF CABINET.
 4. * RA0100 PUMPS ONLY.
 5. THE AMPACITY OF CONDUCTORS SUPPLYING THE CONTROL PANEL TO BE ROUNDED UP TO THE NEXT SIZE LARGER STANDARD WIRE GAUGE.
 6. MOP VALUES TO BE ROUNDED DOWN TO THE NEAREST STANDARD RATING OF THE OVERCURRENT PROTECTION DEVICE.
 7. SHORT CIRCUIT CURRENT RATING (SCCR): 65 kA

MINIMUM RUN TIME VALUES

SYSTEM OFF TIME (MIN-SEC)	NEXT MINIMUM RUN TIME VALUE (MIN)
0:00 TO 1:59	15
2:00 TO 3:59	13
4:00 TO 5:59	11
6:00 TO 7:59	9
8:00 TO 9:59	7
10 OR LONGER	5

VACUUM SWITCH SETTINGS

ALTITUDE	VS-1	VS-2
0-3000'	20"-25"Hg	18"-24"Hg
3001'-4000'	19"-24"Hg	17"-23"Hg
4001'-5000'	18"-23"Hg	16"-22"Hg
5001'-6000'	17"-22"Hg	15"-21"Hg
6001'-7000'	17"-21"Hg	15"-20"Hg
7001'-8000'	16"-20"Hg	14"-19"Hg
8001'-9000'	16"-19"Hg	14"-18"Hg
9001'-10000'	16"-18"Hg	14"-17"Hg

MINIMUM CIRCUIT AMPACITY (MCA)

SYSTEM HP	208 V	230 V	380 V	460 V
1.5 HP	16.6 AMPS	15.1 AMPS	8.7 AMPS	7.8 AMPS
2 HP	18.6 AMPS	16.9 AMPS	10.9 AMPS	8.7 AMPS
3 HP	25.6 AMPS	23.2 AMPS	15.0 AMPS	11.8 AMPS
5 HP	39.3 AMPS	35.8 AMPS	23.1 AMPS	18.1 AMPS
7.5 HP	56.2 AMPS	51.1 AMPS	32.8 AMPS	25.8 AMPS

MAXIMUM OVERCURRENT PROTECTION (MOP)

SYSTEM HP	208 V	230 V	380 V	460 V
1.5 HP	21.5 AMPS	19.5 AMPS	10.7 AMPS	9.8 AMPS
2 HP	24.4 AMPS	22.1 AMPS	14.0 AMPS	11.1 AMPS
3 HP	34.5 AMPS	31.2 AMPS	19.8 AMPS	15.6 AMPS
5 HP	54.3 AMPS	49.4 AMPS	31.5 AMPS	24.7 AMPS
7.5 HP	78.7 AMPS	71.5 AMPS	45.5 AMPS	35.8 AMPS

DUPLEX SYSTEM FULL LOAD AMPERES

SYSTEM HP	208 V	230 V	380V/50Hz	460 V
1.5 HP	11.8 AMPS	10.1 AMPS	6.0 AMPS	5.2 AMPS
2 HP	14.2 AMPS	12.1 AMPS	7.2 AMPS	6.2 AMPS
3 HP	19.4 AMPS	16.9 AMPS	10.2 AMPS	8.6 AMPS
*5 HP	29.0 AMPS	27.7 AMPS	15.6 AMPS	14.0 AMPS
5 HP	31.0 AMPS	27.1 AMPS	16.5 AMPS	13.7 AMPS
7.5 HP	48.2 AMPS	44.9 AMPS	23.8 AMPS	22.6 AMPS

INDIVIDUAL FULL LOAD AMPERES

SYSTEM HP	208 V	230 V	380V/50Hz	460 V
1.5 HP	5.2 AMPS	4.4 AMPS	2.5 AMPS	2.2 AMPS
2 HP	6.4 AMPS	5.4 AMPS	3.1 AMPS	2.7 AMPS
3 HP	9.0 AMPS	7.8 AMPS	4.6 AMPS	3.9 AMPS
*5 HP	13.8 AMPS	13.2 AMPS	7.3 AMPS	6.6 AMPS
5 HP	14.8 AMPS	12.9 AMPS	7.7 AMPS	6.5 AMPS
7.5 HP	23.4 AMPS	21.8 AMPS	11.4 AMPS	10.9 AMPS

FUSE SELECTION CHART (MAX FUSE SIZES SHOWN)

SYSTEM HP	FUSES	208 V	230 V	380 V	460 V
1.5 HP	FL1/FL2/FL3	15 AMPS	15 AMPS	12 AMPS	12 AMPS
2 HP		20 AMPS	17.5 AMPS	12 AMPS	12 AMPS
3 HP		25 AMPS	25 AMPS	15 AMPS	12 AMPS
*5 HP		---	---	20 AMPS	20 AMPS
5 HP		---	---	25 AMPS	17.5 AMPS
7.5 HP	---	---	30 AMPS	30 AMPS	
ALL	F1/F2/F4/F5	6 AMPS	6 AMPS	6 AMPS	6 AMPS
	F3/F6	---	---	6 AMPS	6 AMPS
	F9/F10	2.5 AMPS	2.5 AMPS	2.5 AMPS	2.5 AMPS
	F13	0.7 AMPS	0.7 AMPS	0.7 AMPS	0.7 AMPS

FL1/FL2/FL3 ARE LITTELFUSE JTD 600V TYPE
 F1-F6 ARE LITTELFUSE KLDR 600V TYPE
 F9-F10/F13 ARE LITTELFUSE 2AG 250V TYPE

OPERATION:

DURING NORMAL OPERATION, THE HOA SWITCHES SHOULD BE IN THE AUTO POSITION. THE PLC WILL SIGNAL THE LEAD PUMP TO START WHEN VS-1 CLOSSES WITH FALLING VACUUM LEVEL, BUT THE SIGNAL TO STOP IS BASED ON THE LENGTH OF TIME THE VACUUM SYSTEM WAS NOT RUNNING. THE PLC DETERMINES THE MINIMUM RUNNING TIME OF A PUMP ONCE IT STOPS. IF THE VACUUM SYSTEM IS STOPPED FOR A LONG PERIOD OF TIME, THEN THE MINIMUM RUN TIME AFTER A RESTART WILL BE SHORT. IF THE VACUUM SYSTEM IS STOPPED FOR A SHORT PERIOD OF TIME, THEN THE MINIMUM RUNNING TIME WILL BE LONGER UP TO A MAXIMUM OF 15 MINUTES AFTER VS-1 OPENS (SEE CHART). AFTER VS-1 OPENS AND THE MINIMUM RUN TIMER HAS EXPIRED, THE PUMP THAT IS RUNNING WILL TURN OFF. WHEN VS-1 CLOSSES AGAIN, THE PLC WILL SEQUENCE THE LEAD ROLE TO THE OTHER PUMP. IF DURING OPERATION THE SECOND PUMP IS REQUIRED TO COME ON, THE PLC WILL TURN ON THE "LAG ALARM".

HAND OPERATION; (EMERGENCY/TROUBLE SHOOTING MODE ONLY)

PUMPS WITH THE HOA SWITCH IN THE HAND POSITION WILL START AND RUN CONTINUOUSLY.

PLC FAULT; IF A PLC FAULT OCCURS, VACUUM PUMPS WILL START AND RUN CONTINUOUSLY. VACUUM PUMPS CAN OPERATE IN THIS CONDITION UNTIL PLC FAULT IS REPAIRED.

NOTE:
 AUXILIARY CONTACTS 70-75 ARE "CLASS 1 CONTROL CIRCUITS. USE CLASS 1 CONDUCTORS."

AUX CONTACTS ARE RATED 10A @ 120VAC UNLESS OTHERWISE NOTED.

AUX CONTACTS CLOSED DURING NORMAL OPERATION.

Revised: GTM	Date: 09/25/19	Drawn: MDB	Date: 10/30/18
		This drawing and the information contained thereon remain the property of BeaconMedics and may not be used for other than the purpose for which it is loaned without the expressed written permission from BeaconMedics Engineering.	
Description: DWG WIRING CONTROL DX LUBE 1-7.5HP BASIC 208-460/3/50-60, 65kA		Part Number: 4107 8568 62	
Sheet 1 of 1		DN: HOP191127	Rev: 01
		DO NOT SCALE THIS DOCUMENT	

1.5, 2 & 3HP 208-460V
 5 & 7.5HP 380-460V
 SCCR: 65 kA

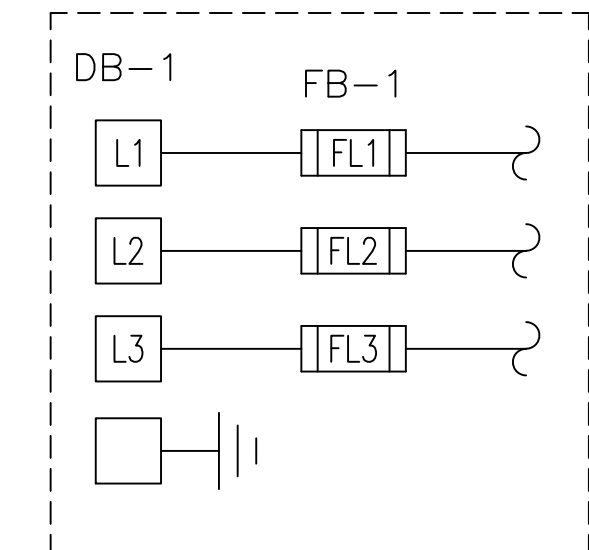

5 & 7.5HP 208-230V
 SCCR: 65 kA

