

Note X:
 - Dimension drawing standardized
 - Air inlet flange details added
 - Mk-IV Elektronikon changed to Mk5

Approx. Mass ±110 (LBS)		Center of gravity ±2 (inch)	
Type	Pack	Dim	Pack
ZT37VSD	3155	W	20.4
ZT55VSD	3274	L	44.8
		H	29.6

Ed.	Post.	See Note X	Geveerd van	2011-05-20	Ingev./Goedg.
Num.			Modified from	Date	Int./Appr.

All materials supplied are in compliance with the requirements of the List of Prohibited Substances

9820577200	01.11
Parent 3D model	Ed. Version 3D

Tolerances, if not indicated, according to:		ATLAS COPCO STANDARD CLASS	
Name	DIMENS.	ZT37-55VSD+MED	Secrecy Class
Material	NOT APPLICABLE		112/1 3
Treatment	Not Applicable		INV
Scale	1:10	Family	A/Compare
Version Dwg	02.13	Blank no.	Replaces
Des. checked.	Prod. checked.	Approved.	Date
Blank wt.	0 kg	Phi wt.	452,918 kg
Designation	9820577200		
STATUS	Approved		
Sheet	1 / 1		

Note:
 * With full open door

Notes:

1. ALLOW A MINIMUM OF (2) FEET ON ALL SIDES OF DRYER PACKAGE FOR PROPER VENTILATION AND MAINTENANCE.
2. BASEFRAMES ARE SHIPPED TOGETHER AND CAN BE UNBOLTED FOR PASSAGE THROUGH A STANDARD DOOR.
3. SHIPPING WIGHT: 1798 LBS.
4. SYSTEM CAPACITY: 211 CFM.
5.  INDICATES CENTER OF GRAVITY.

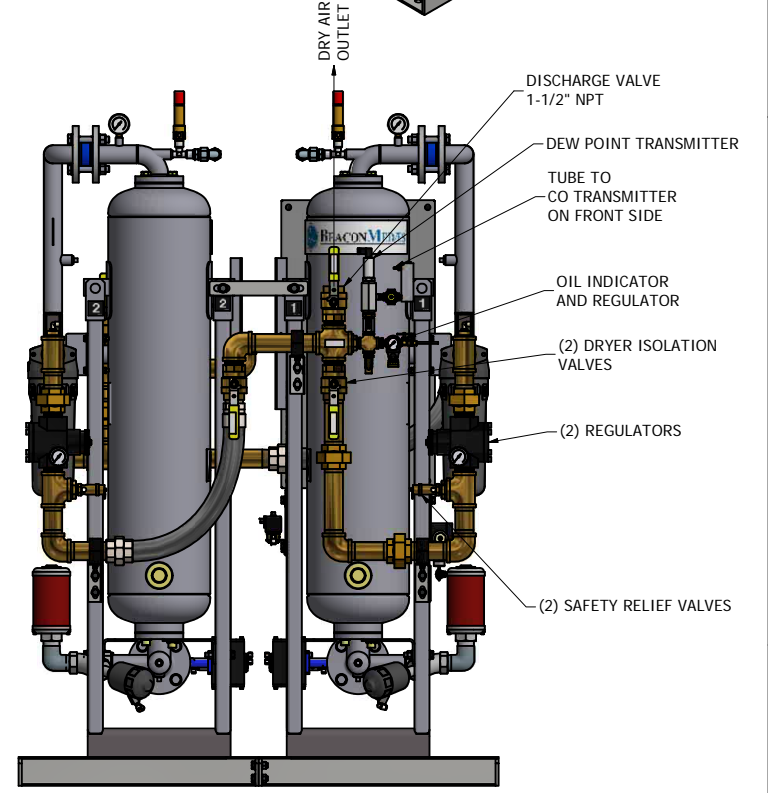
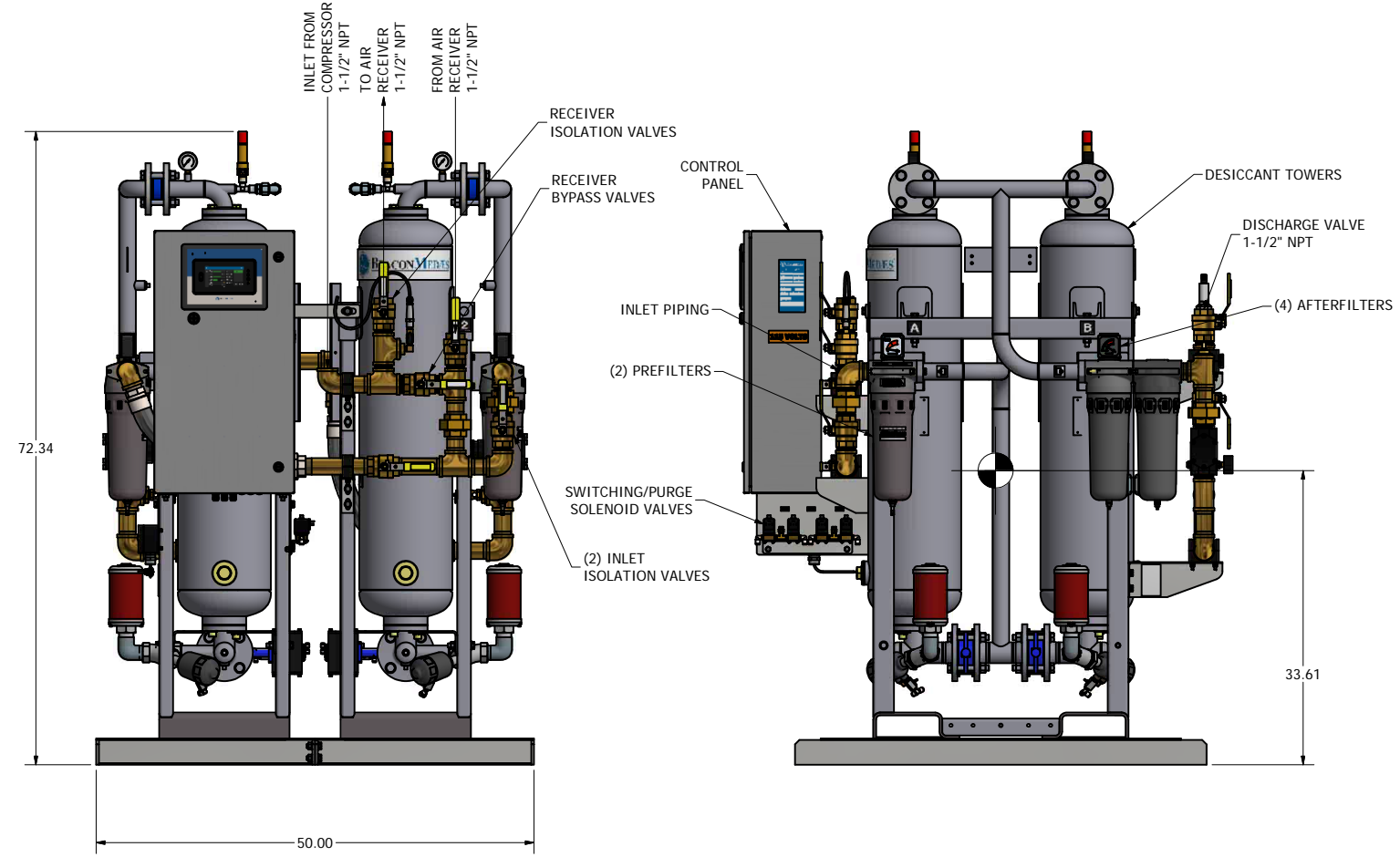
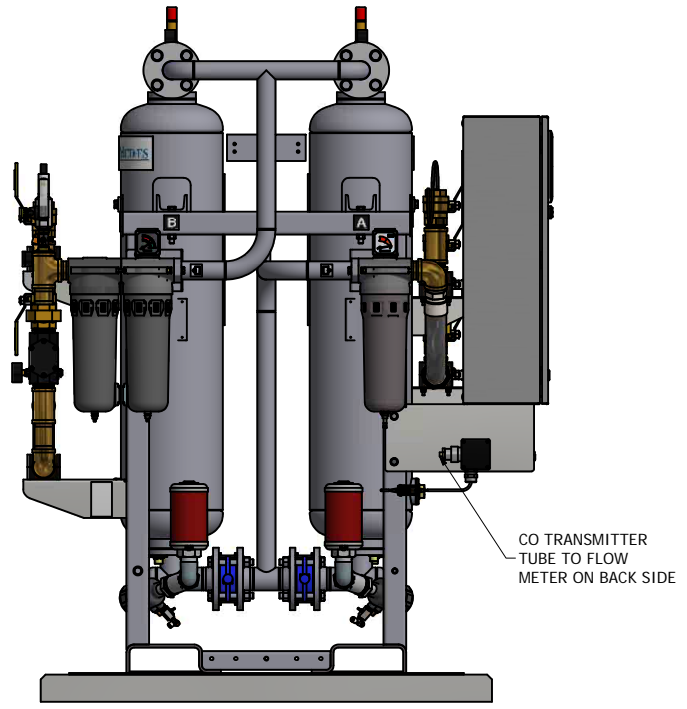
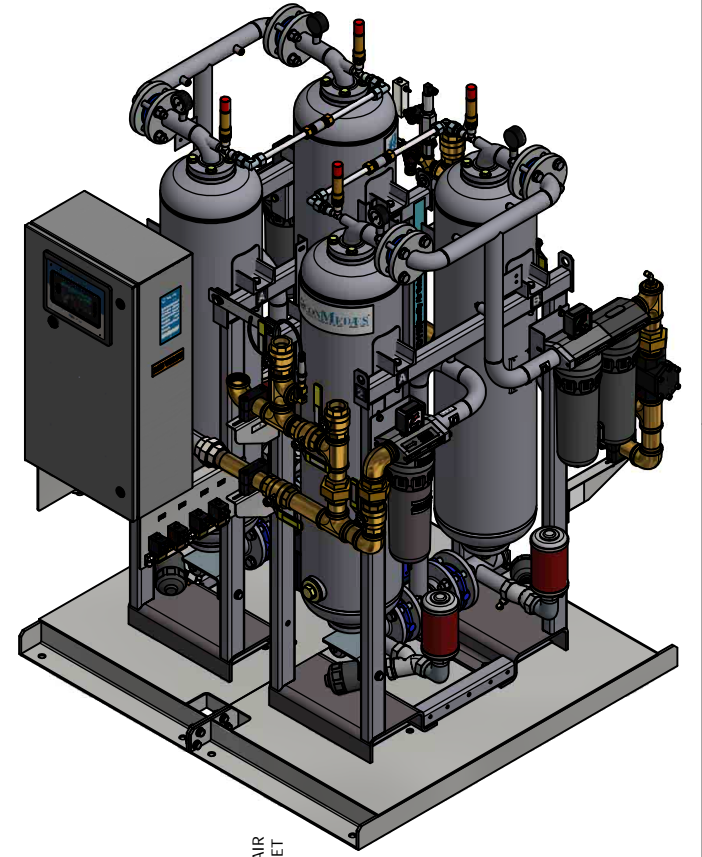
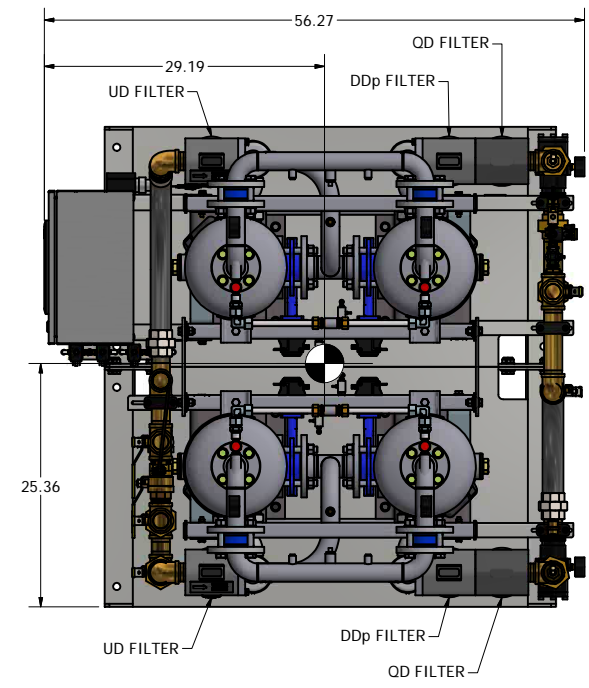
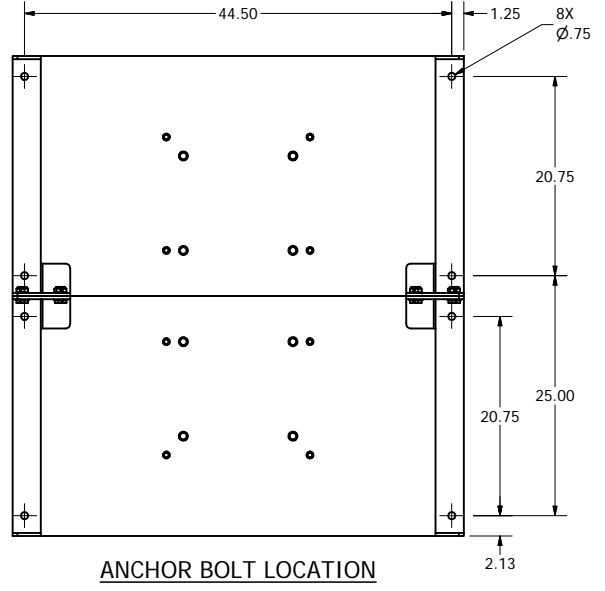

Revised:	Date:	Drawn:	Date:
		MDB	9/30/2020
		This drawing and the information contained therein remain the property of BeaconMedes and may not be used for other than the purpose for which it is loaned without the expressed written permission from BeaconMedes Engineering.	
Description: GEN ASM CD110 DRYER MODULE 211 CFM, Z-MED MEDICAL AIR SYSTEM MK5 TOUCH		Drawing Number: 4107 8563 69	Scale: 1/10 D
DN: HOP200566		Rev: 00	DO NOT SCALE THIS DOCUMENT
Sheet 1 of 2		1	

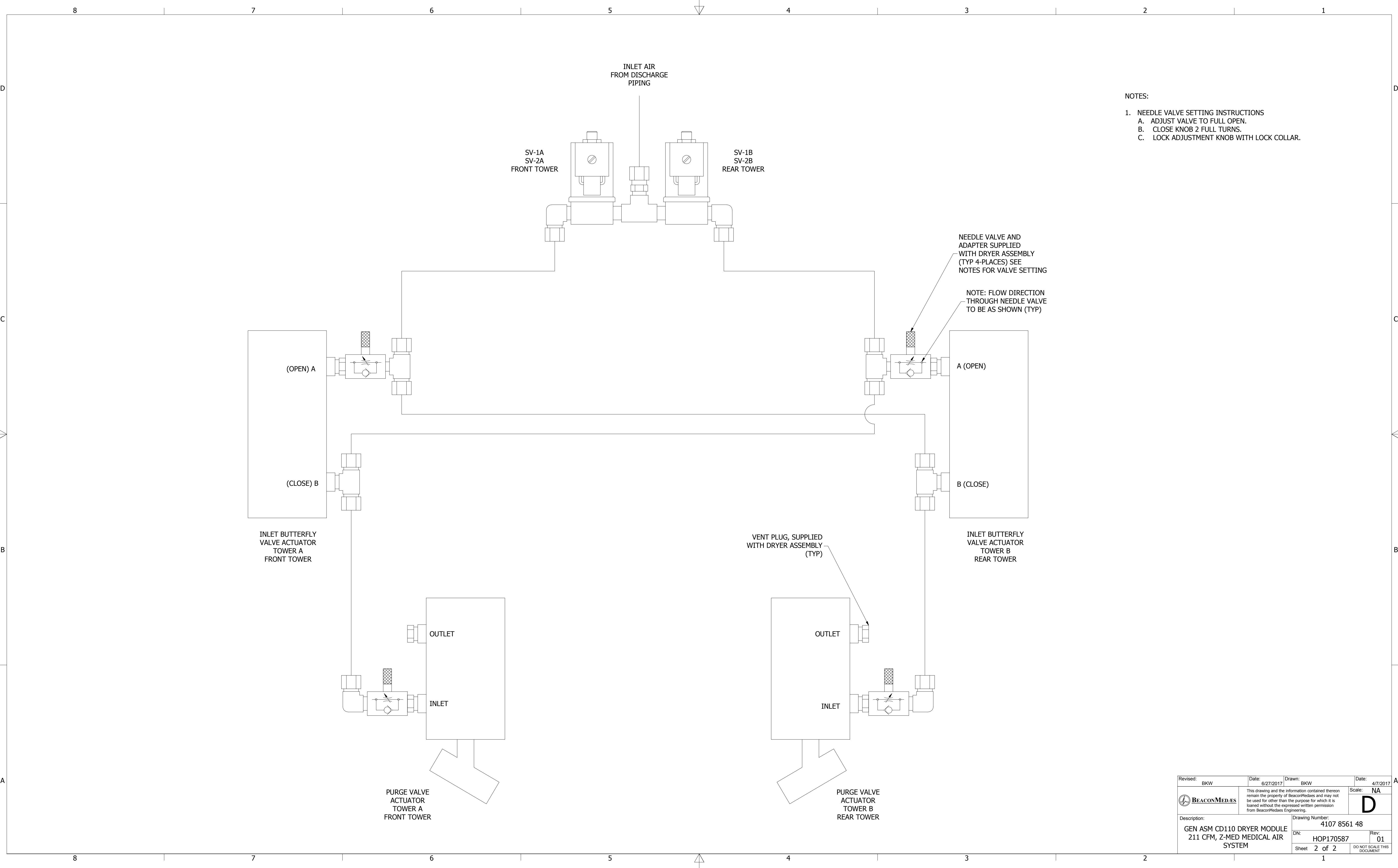

- NOTES:
- NEEDLE VALVE SETTING INSTRUCTIONS
 - ADJUST VALVE TO FULL OPEN.
 - CLOSE KNOB 2 FULL TURNS.
 - LOCK ADJUSTMENT KNOB WITH LOCK COLLAR.

NEEDLE VALVE AND ADAPTER SUPPLIED WITH DRYER ASSEMBLY (TYP 4-PLACES) SEE NOTES FOR VALVE SETTING

NOTE: FLOW DIRECTION THROUGH NEEDLE VALVE TO BE AS SHOWN (TYP)

VENT PLUG, SUPPLIED WITH DRYER ASSEMBLY (TYP)

Revised: BKW	Date: 6/27/2017	Drawn: BKW	Date: 4/7/2017
		This drawing and the information contained herein remain the property of BeaconMedaes and may not be used for other than the purpose for which it is loaned without the expressed written permission from BeaconMedaes Engineering.	
Description: GEN ASM CD110 DRYER MODULE 211 CFM, Z-MED MEDICAL AIR SYSTEM		Drawing Number: 4107 8561 48	Scale: NA
DN: HOP170587	Rev: 01		
Sheet 2 of 2	DO NOT SCALE THIS DOCUMENT		

- Notes:
1. ASME CODE CONSTRUCTION.
 2. DESIGN PRESSURE: 200 PSI AT 400°F.
 3. NATION BOARD REGISTERED.
 4. ALL OPENINGS ARE NPT THREADED.
 5. WEIGHT: 775 LBS (TANK) AND 22 LBS (SIGHT GLASS ASM).
 6.  DENOTES CENTER OF GRAVITY.

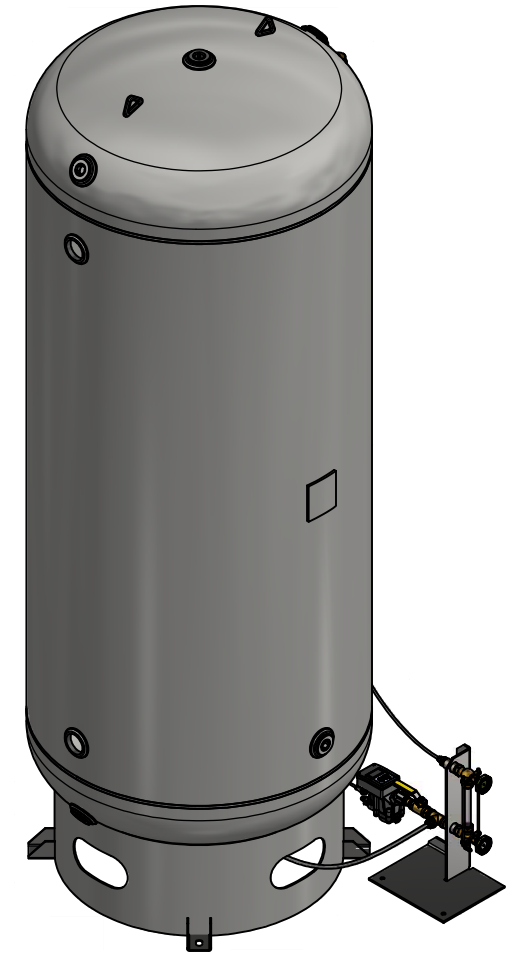
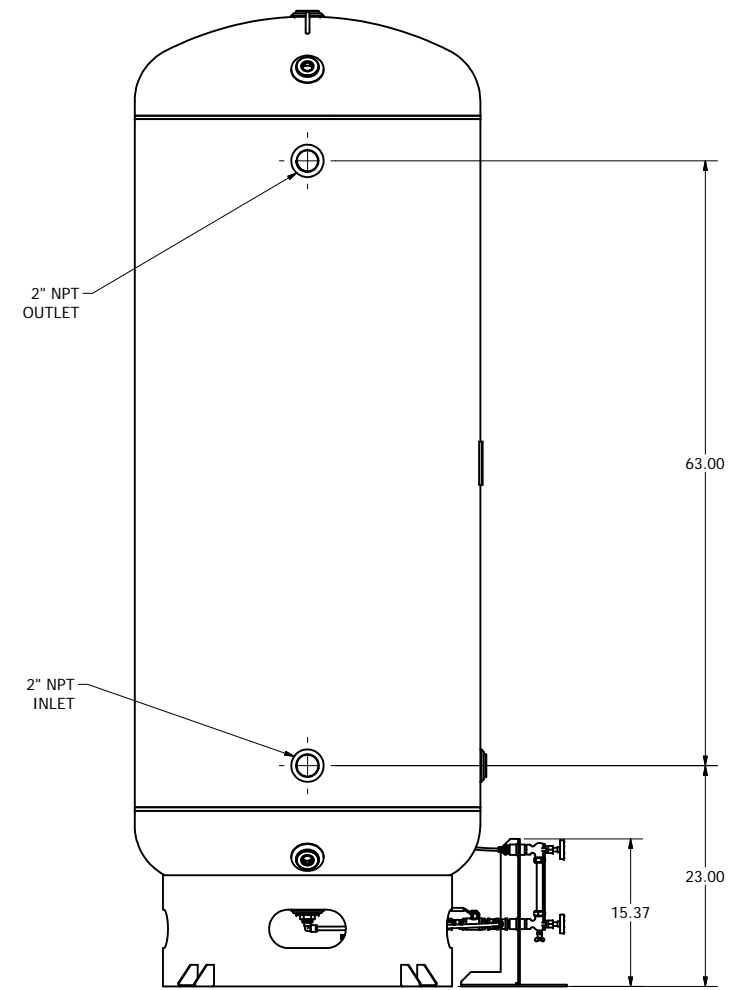
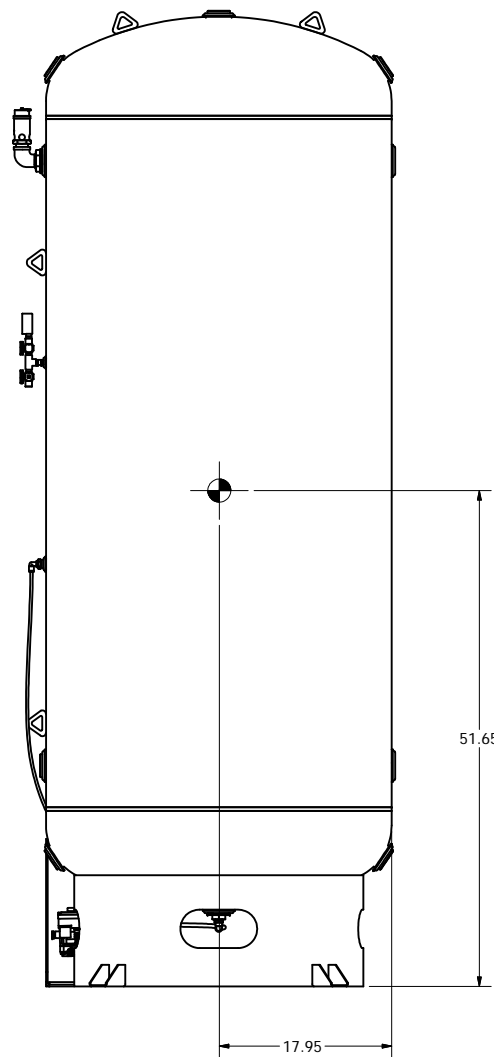
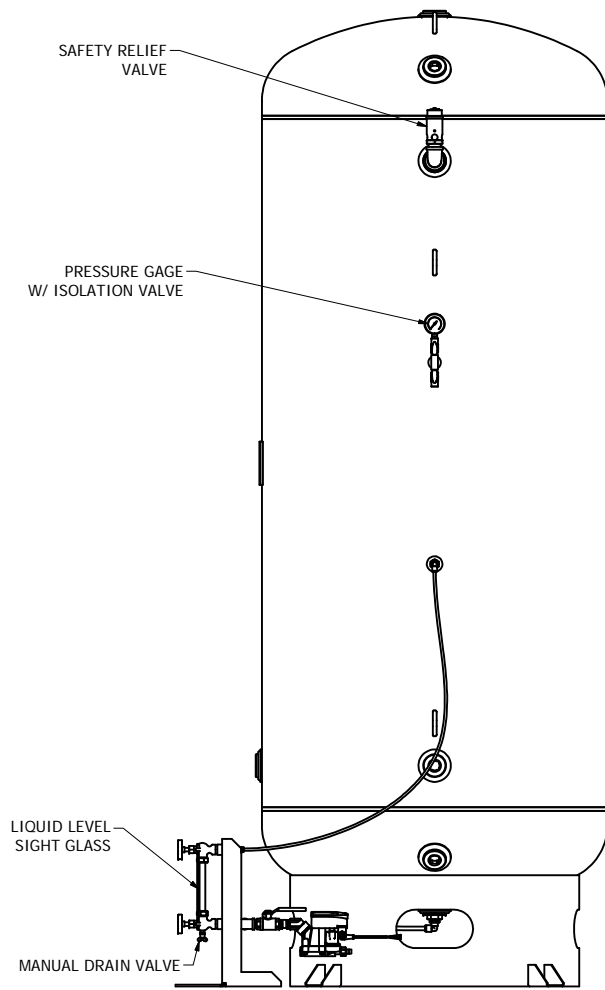
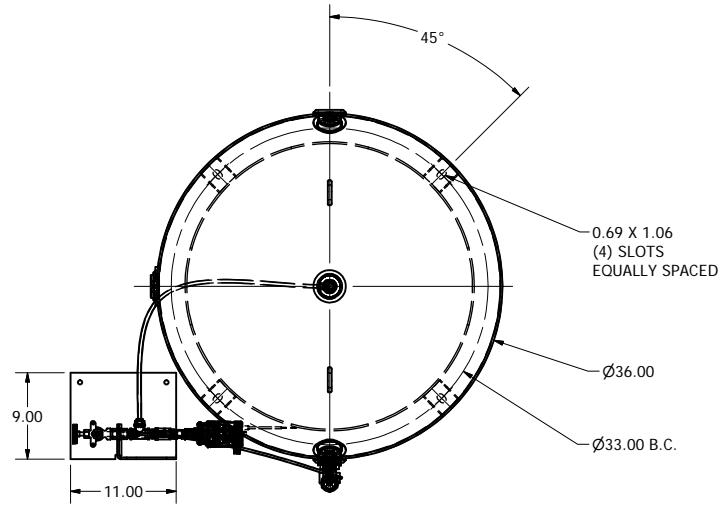

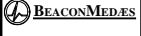
Revised:	Date:	Drawn: MDB	Date: 7/8/2021
		This drawing and the information contained therein remain the property of BeaconMedes and may not be used for other than the purpose for which it is loaned without the expressed written permission from BeaconMedes Engineering.	
Description: AIR RECEIVER TANK - 400 GALLON W/STAND ALONE SIGHT GLASS & DRAIN		Drawing Number: 4107 0082 32	Scale: 1/10
DN: HOP211010		Rev: 00	Sheet 1 of 1
		DO NOT SCALE THIS DOCUMENT	