







This drawing and the information contained thereon remain the property of BeaconMedes and may not be used for other than the purpose for which it is loaned without the expressed written permission from BeaconMedes Engineering.

Notes:

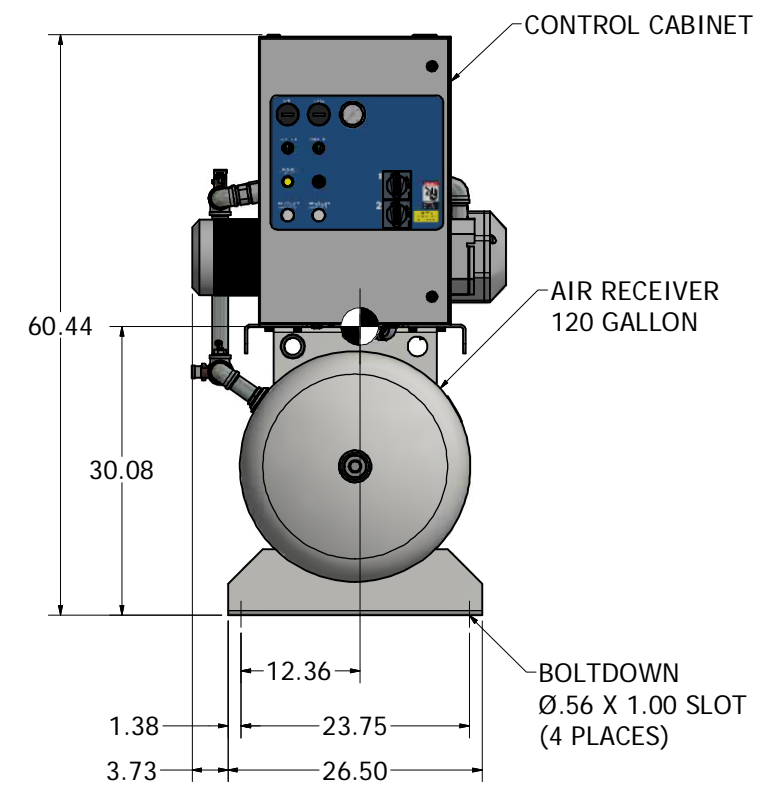
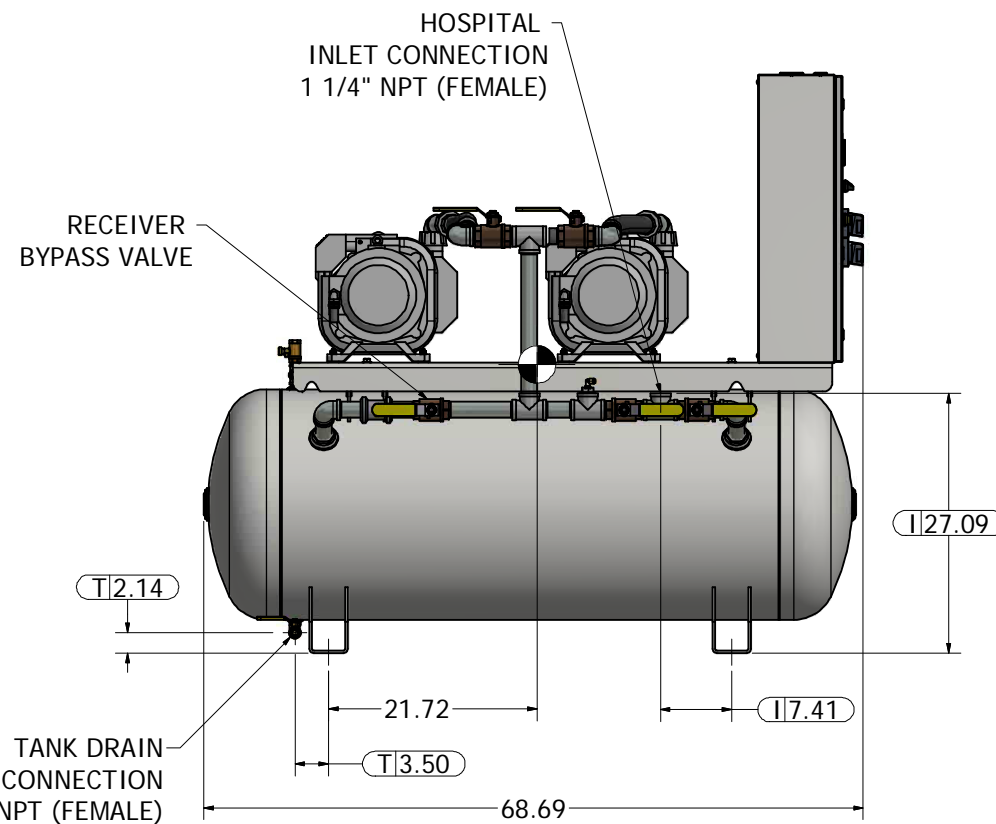
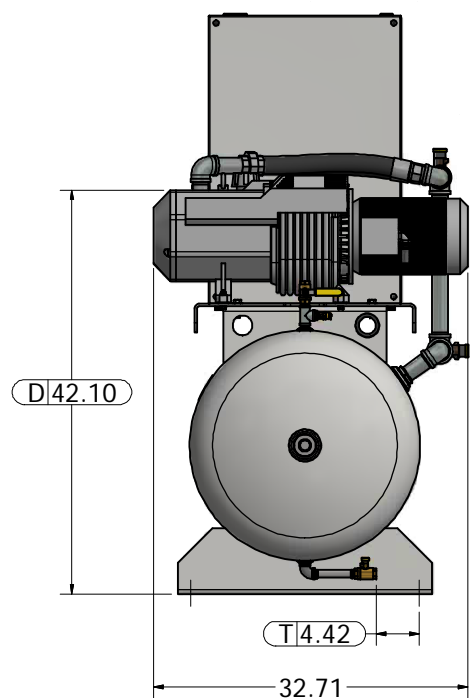
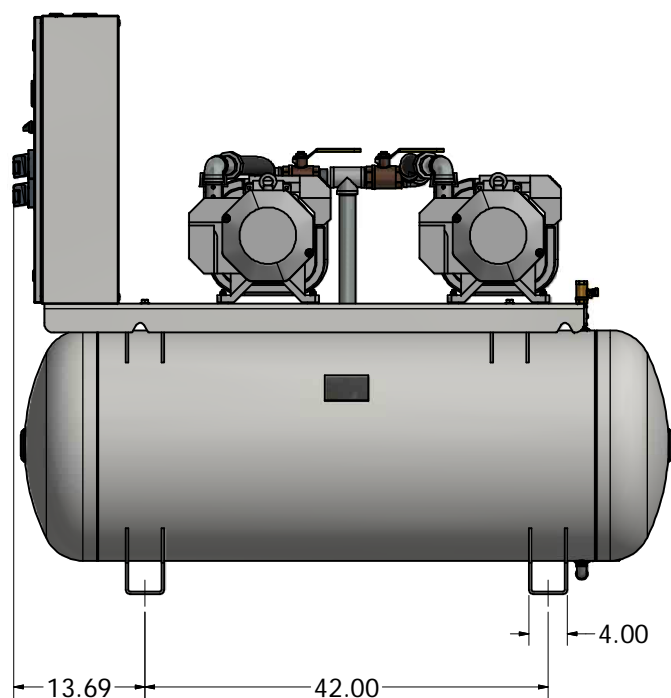
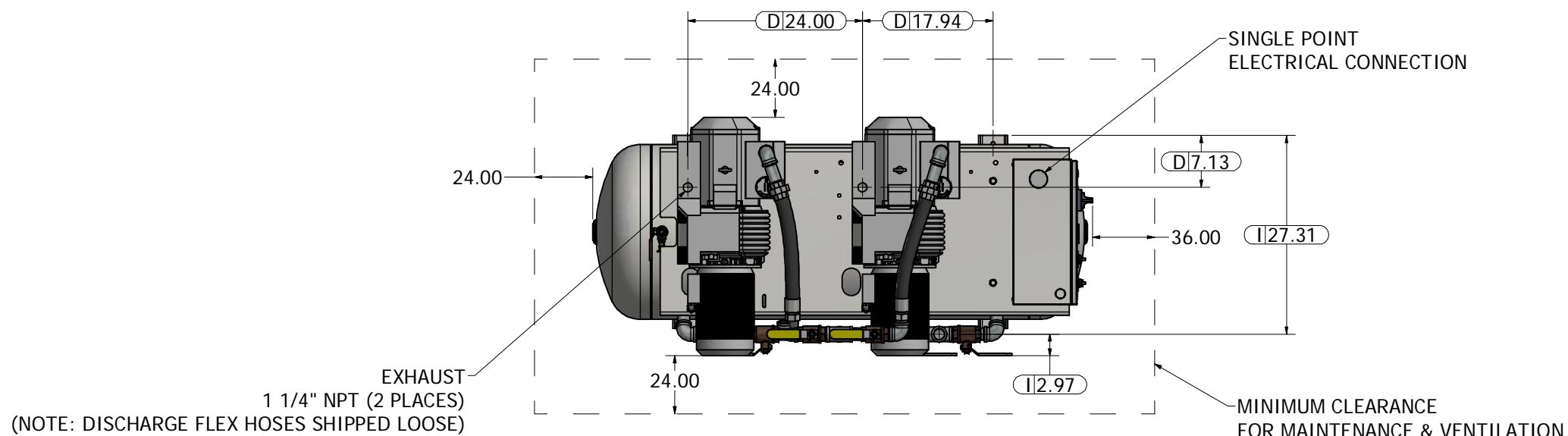
1. SYSTEM WEIGHT: 1132 LBS
2.  INDICATES LIFTING POINTS
3.  DENOTES CENTER OF GRAVITY

SYSTEM CONNECTIONS	
ID	DESCRIPTION
I	INLET LOCATION
D	DISCHARGE LOCATION
T	TANK DRAIN



Revised: MDB	Date: 05/13/2019	Drawn: JOL	Date: 07/03/2015
INSPECTION CHECKLIST UNLESS OTHERWISE SPECIFIED:		  ALL ITEMS MARKED BY ONE OF THE ABOVE SYMBOLS ARE TO BE INSPECTED EQUIPMENT TO BE USED DURING RECEIVING INSPECTION SHALL BE PER QUALITY SYSTEM PROCEDURES	
 BEACONMEDES UNLESS OTHERWISE SPECIFIED ALL DIMENSIONS ARE IN INCHES AND TOLERANCES ARE: XX ± .02 XXX ± .005 ANGLES ± .5°		Scale: D	
Description: GENERAL ASSEMBLY DX 5HP DRY HTM V 120G BASIC		Part Number: 4107 8553 27	
DN: BM190344		Rev: 01	
Sheet 1 of 1		DO NOT SCALE THIS DOCUMENT	