



This drawing and the information contained thereon remain the property of BeaconMedes and may not be used for other than the purpose for which it is loaned without the expressed written permission from BeaconMedes Engineering.

Notes:

1. SYSTEM WEIGHT: 613 LBS
2.  INDICATES LIFTING POINTS
3.  DENOTES CENTER OF GRAVITY

SYSTEM CONNECTIONS	
ID	DESCRIPTION
I	INLET LOCATION
D	DISCHARGE LOCATION
T	TANK DRAIN

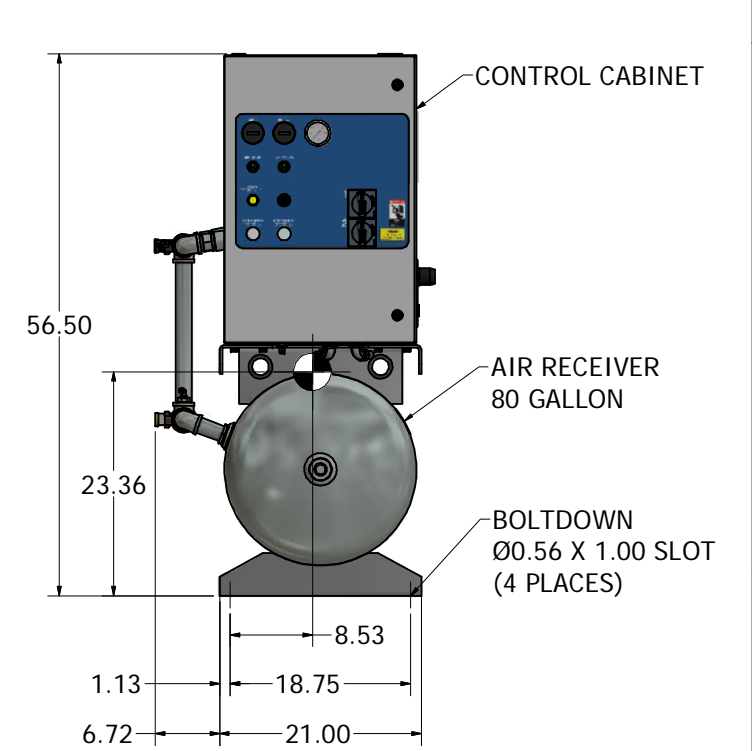
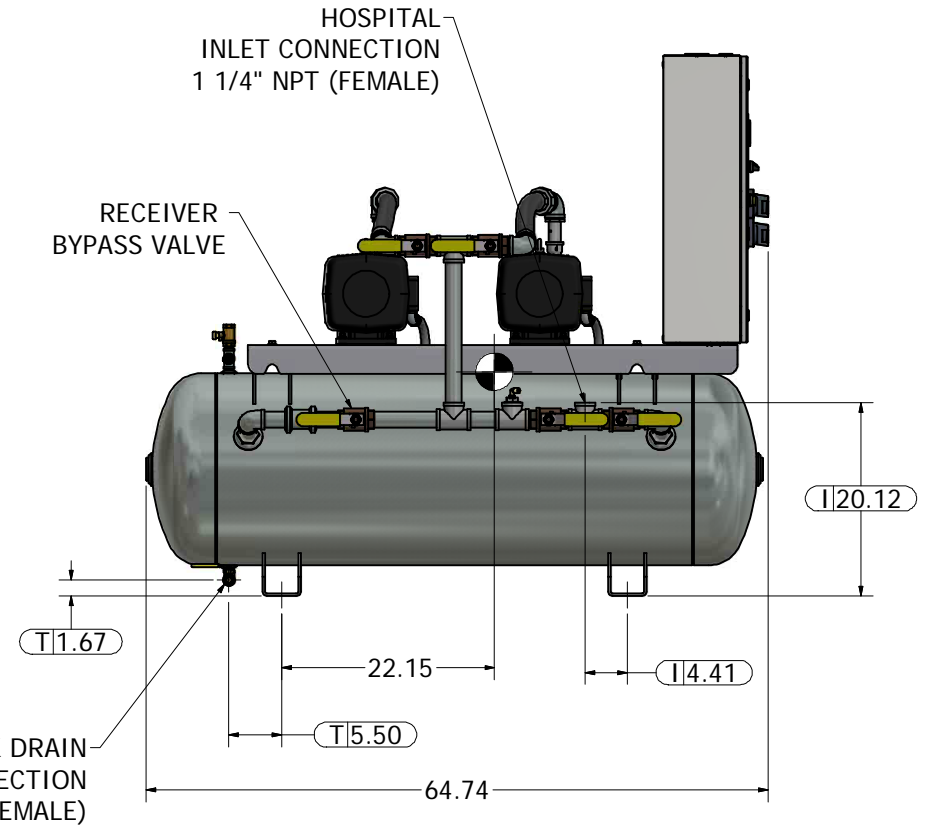
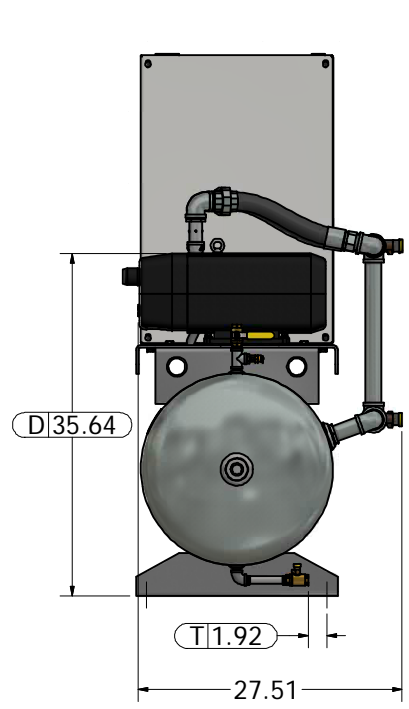
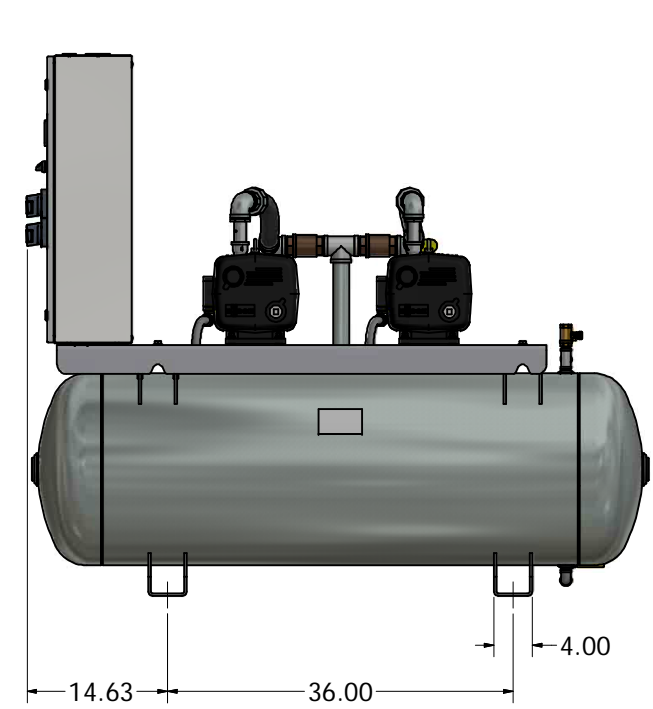
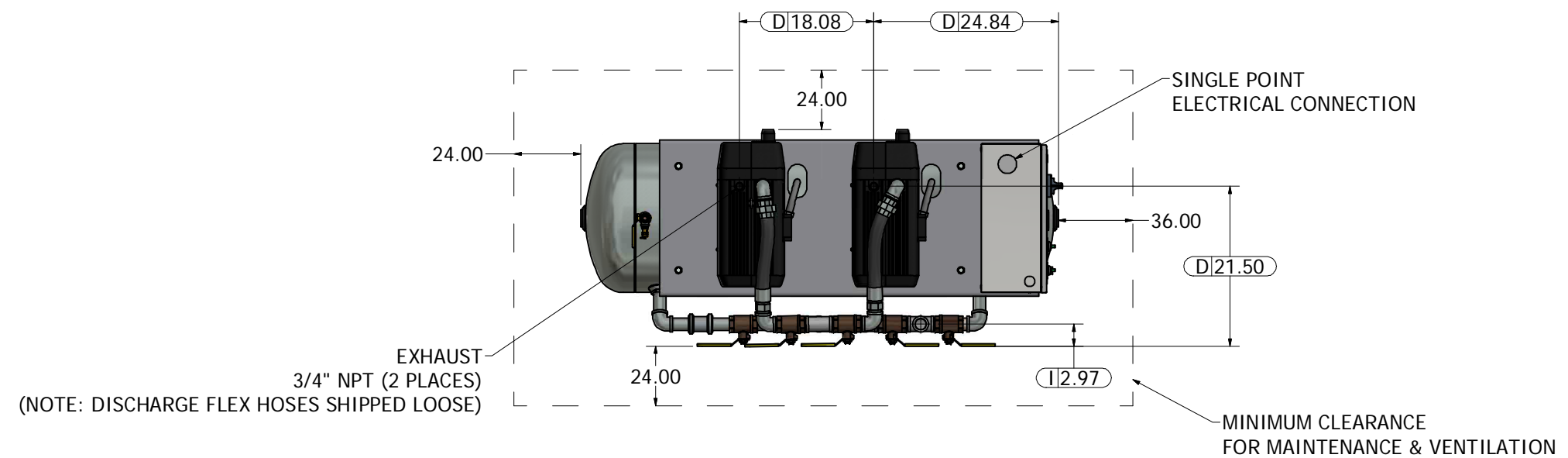

Revised: MDB	Date: 05/16/2019	Drawn: JOL	Date: 07/03/2015
INSPECTION CHECKLIST UNLESS OTHERWISE SPECIFIED:		UNLESS OTHERWISE SPECIFIED ALL DIMENSIONS ARE IN INCHES AND TOLERANCES ARE: XXX ± .02 XXX ± .005	
ALL ITEMS MARKED BY ONE OF THE ABOVE SYMBOLS ARE TO BE INSPECTED		Scale: D	
EQUIPMENT TO BE USED DURING RECEIVING INSPECTION SHALL BE PER QUALITY SYSTEM PROCEDURES		Description: GENERAL ASSEMBLY DX 1.5HP DRY HTM V 80G BASIC	Part Number: 4107 8553 21
		DN: BM190344	Rev: 02
		Sheet 1 of 1	DO NOT SCALE THIS DOCUMENT