

- Notes:
- DX MODULE WEIGHT: 1,424 LBS  
200G TANK WEIGHT: 618 LBS
  - ☒ INDICATES LIFTING POINT.
  - DENOTES CENTER OF GRAVITY.

SYSTEM CONNECTIONS	
ID	DESCRIPTION
I	INLET LOCATION
D	DISCHARGE LOCATION
C	CONDENSATE DRAIN LOCATION
T	TANK DRAIN

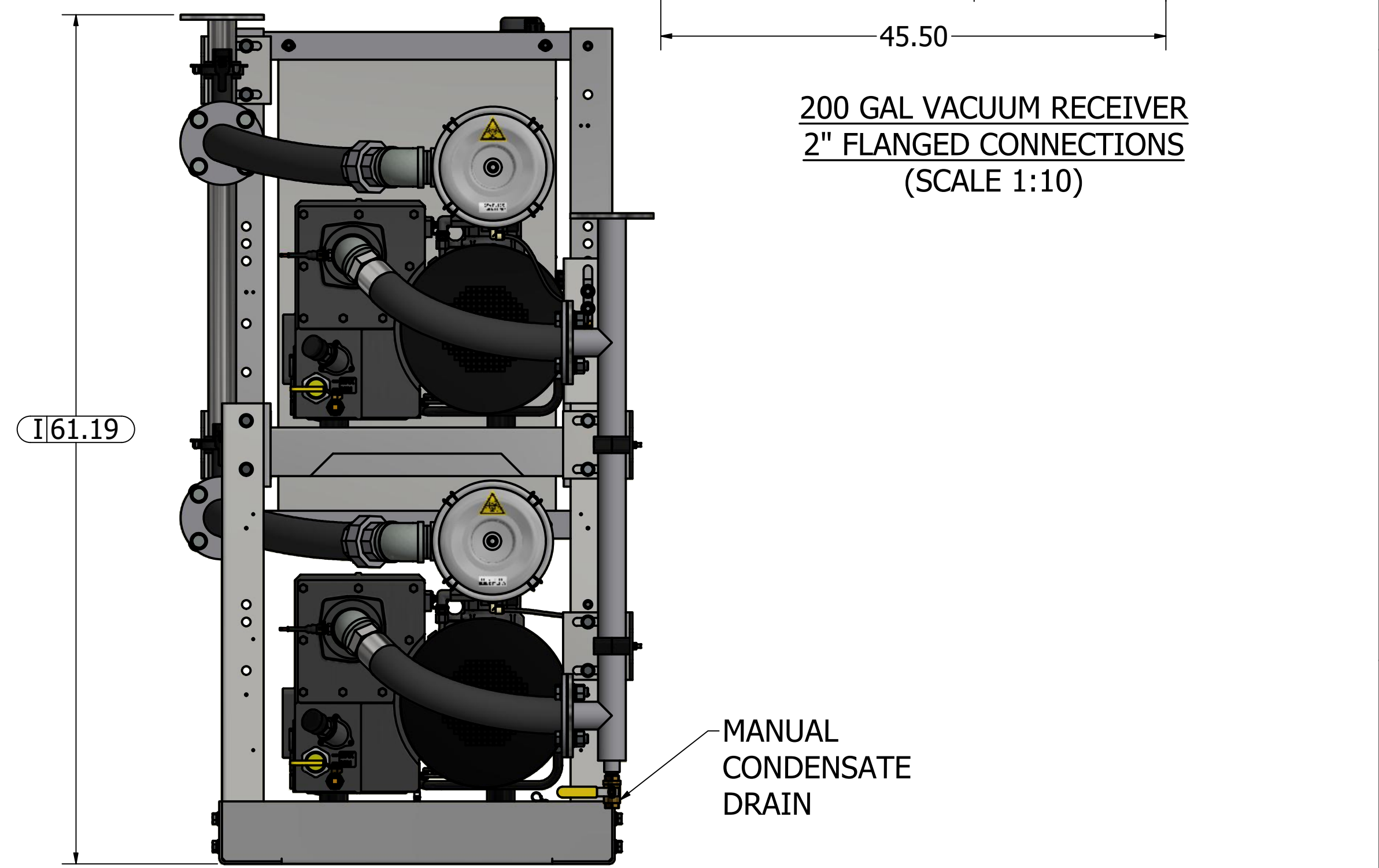
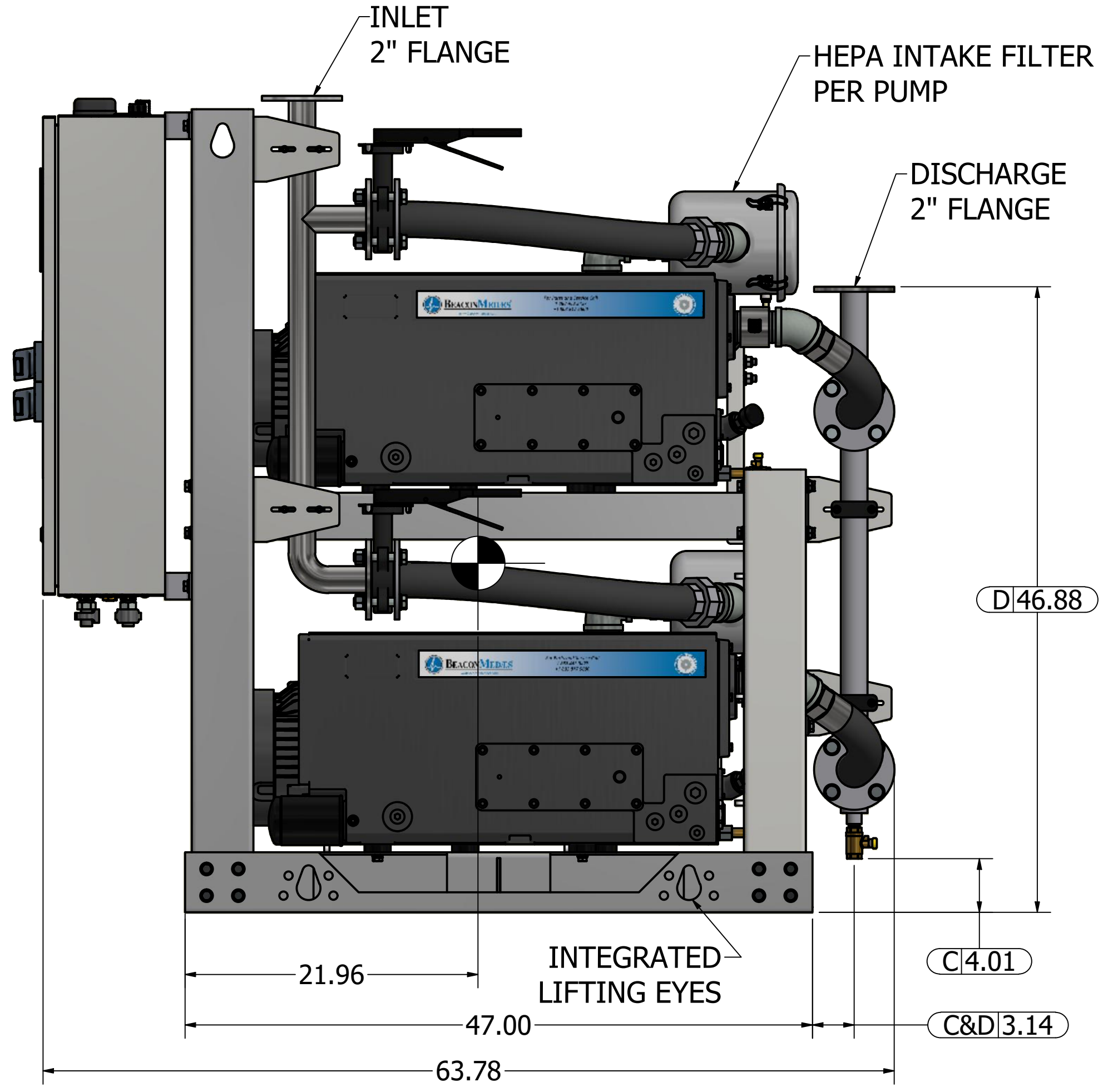
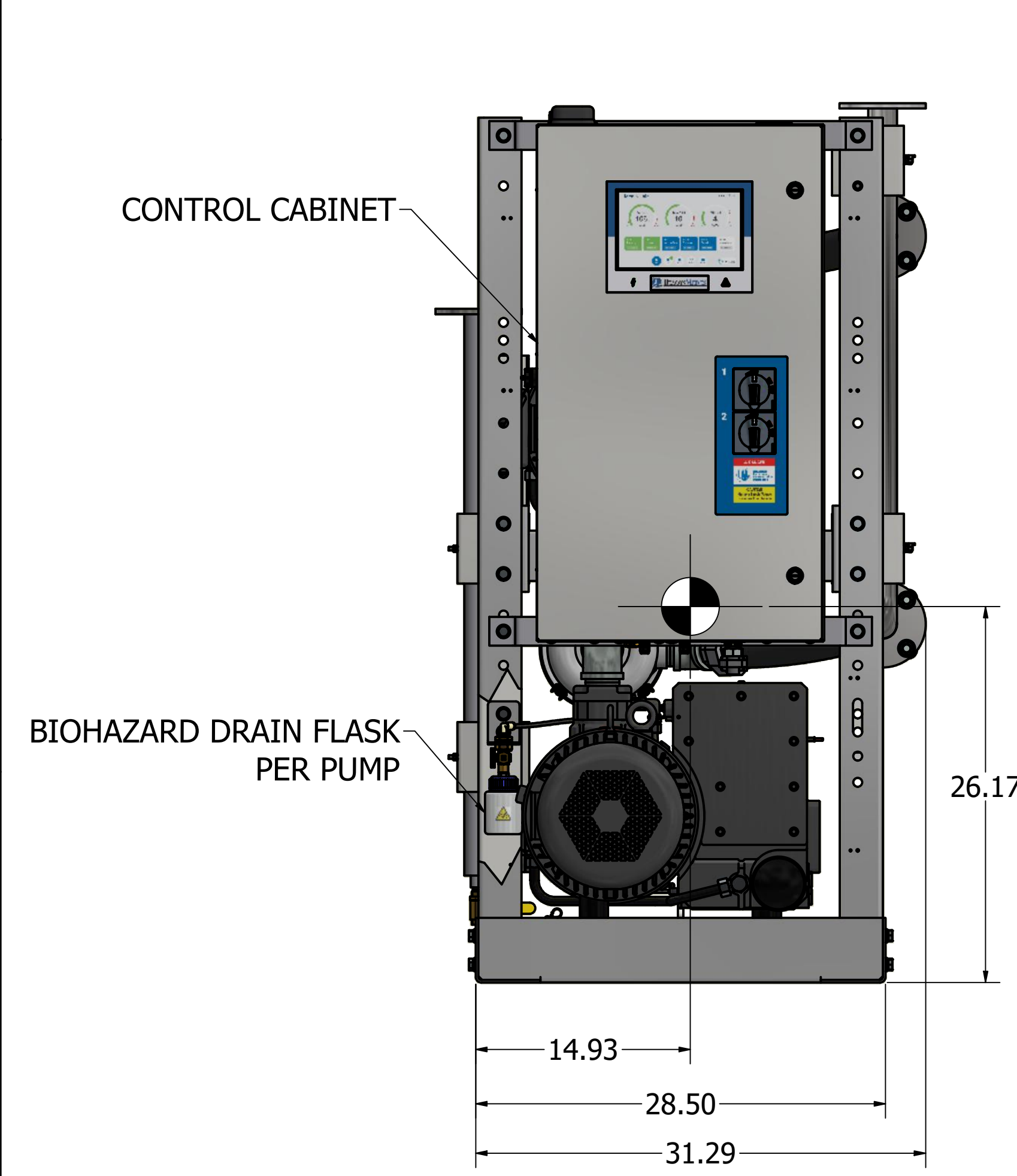
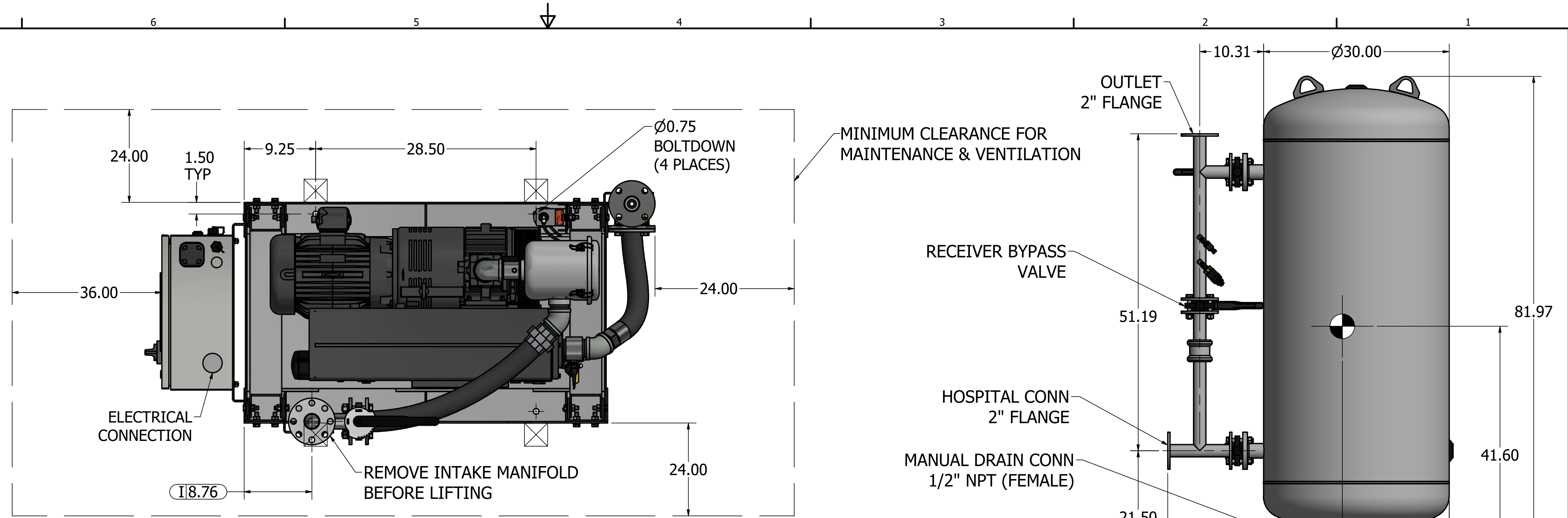

200 GAL VACUUM RECEIVER  
2" FLANGED CONNECTIONS  
(SCALE 1:10)

Revised: APS	Date: 3/24/2023	Drawn: USNKW	Date: 10/20/2010
		This drawing and the information contained therein remain the property of BeaconMedaes and may not be used for other than the purpose for which it is loaned without the expressed written permission from BeaconMedaes Engineering.	
Description: GENERAL ASSEMBLY 7.5HP DX LUBE VAC MOD 200G RECEIVER		Part Number: 4107 8522 09	
Sheet 1 of 1		DN: HOP230842	Rev: 03
		DO NOT SCALE THIS DOCUMENT	