

Notes:

- DISCHARGE MUFFLER WILL BE SHIPPED LOOSE.
- SYSTEM WEIGHT: 4,529.5 LBS.
(INCLUDES FUTURE EXPANSION PUMP)
- ☒ INDICATES LIFTING POINT.
- ⊙ DENOTES CENTER OF GRAVITY.
(INCLUDES FUTURE EXPANSION PUMP)

SYSTEM CONNECTIONS	
ID	DESCRIPTION
I	INLET LOCATION
D	DISCHARGE LOCATION
T	TANK DRAIN LOCATION
C	CONDENSATE DRAIN LOCATION

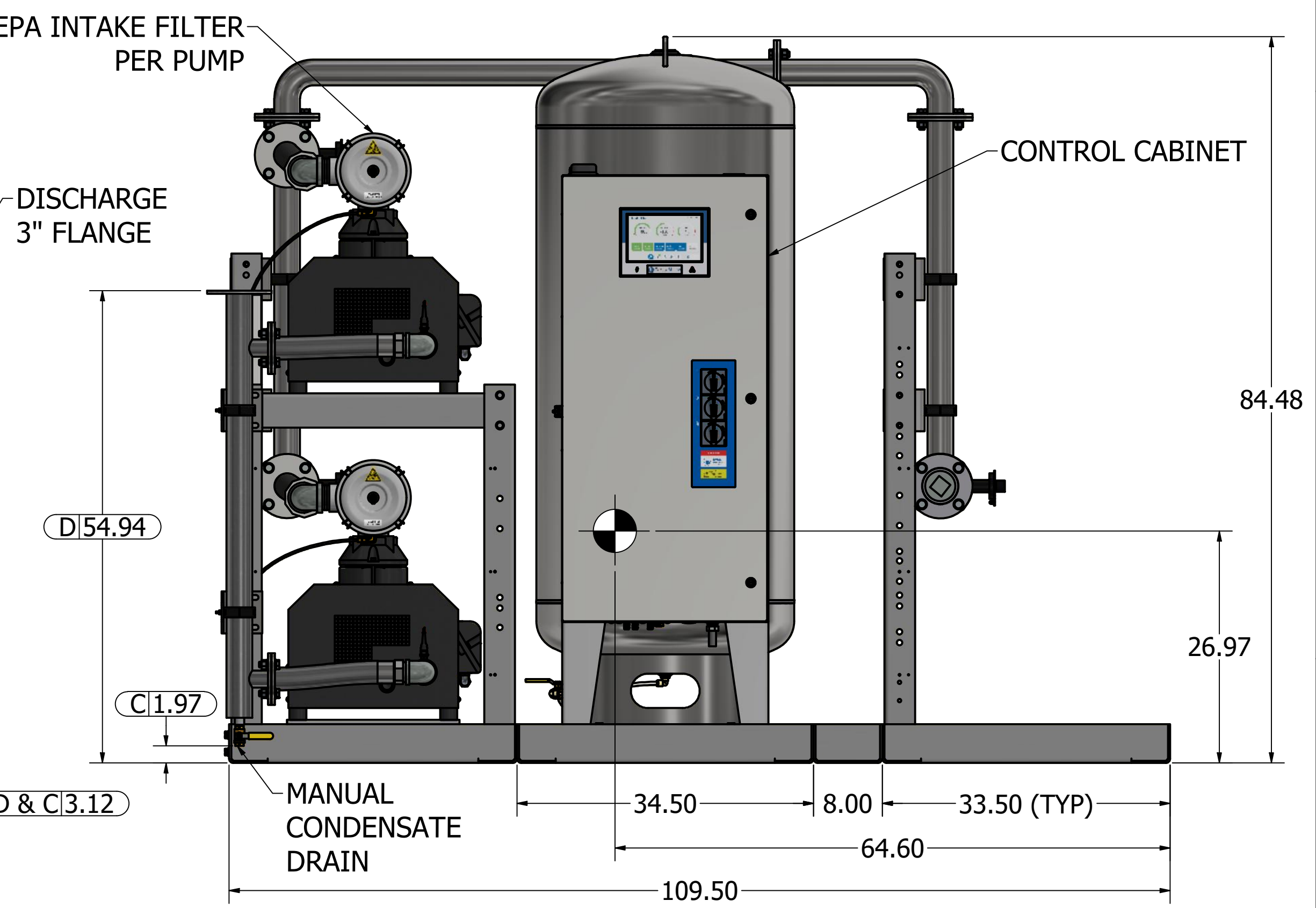
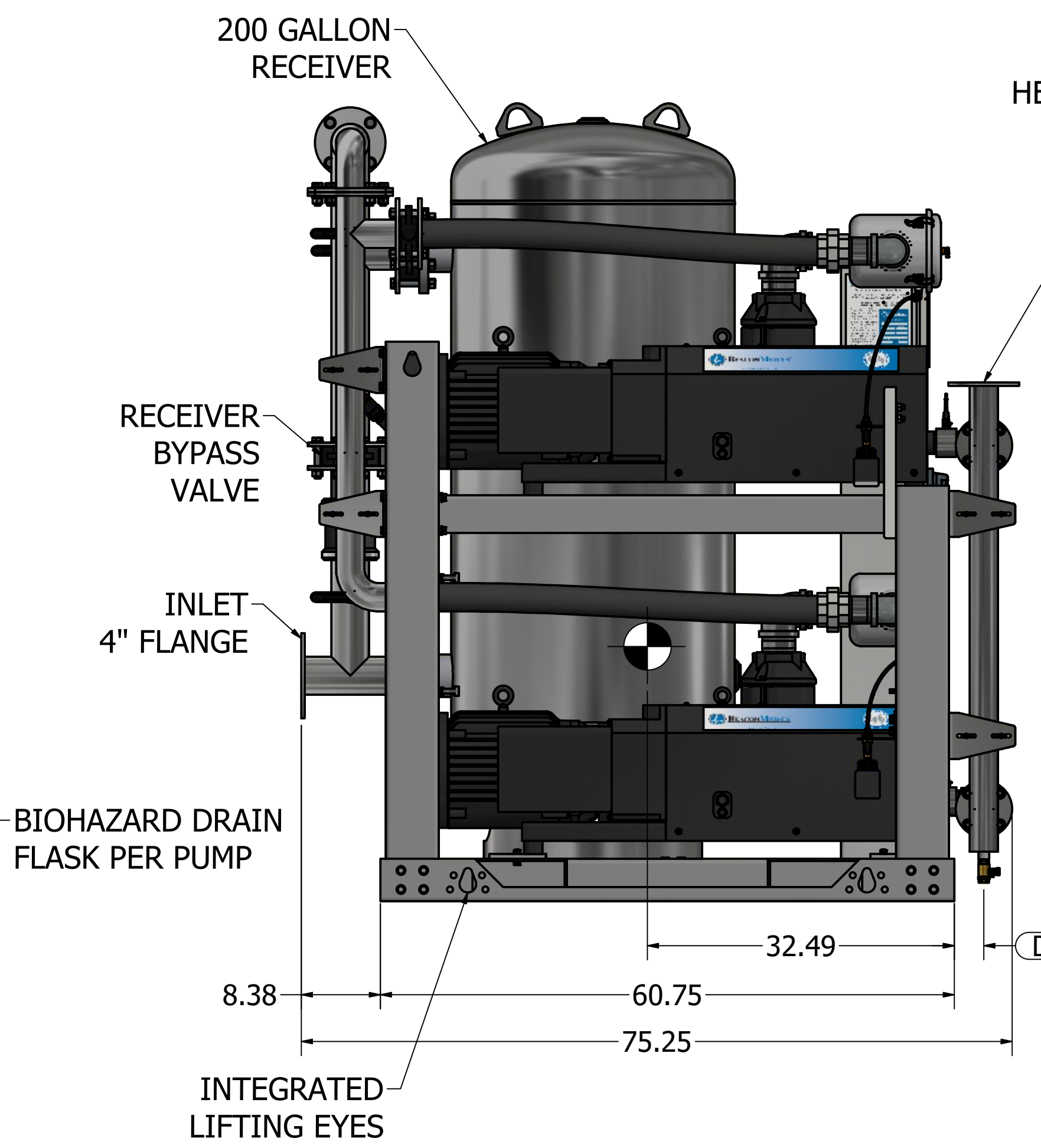
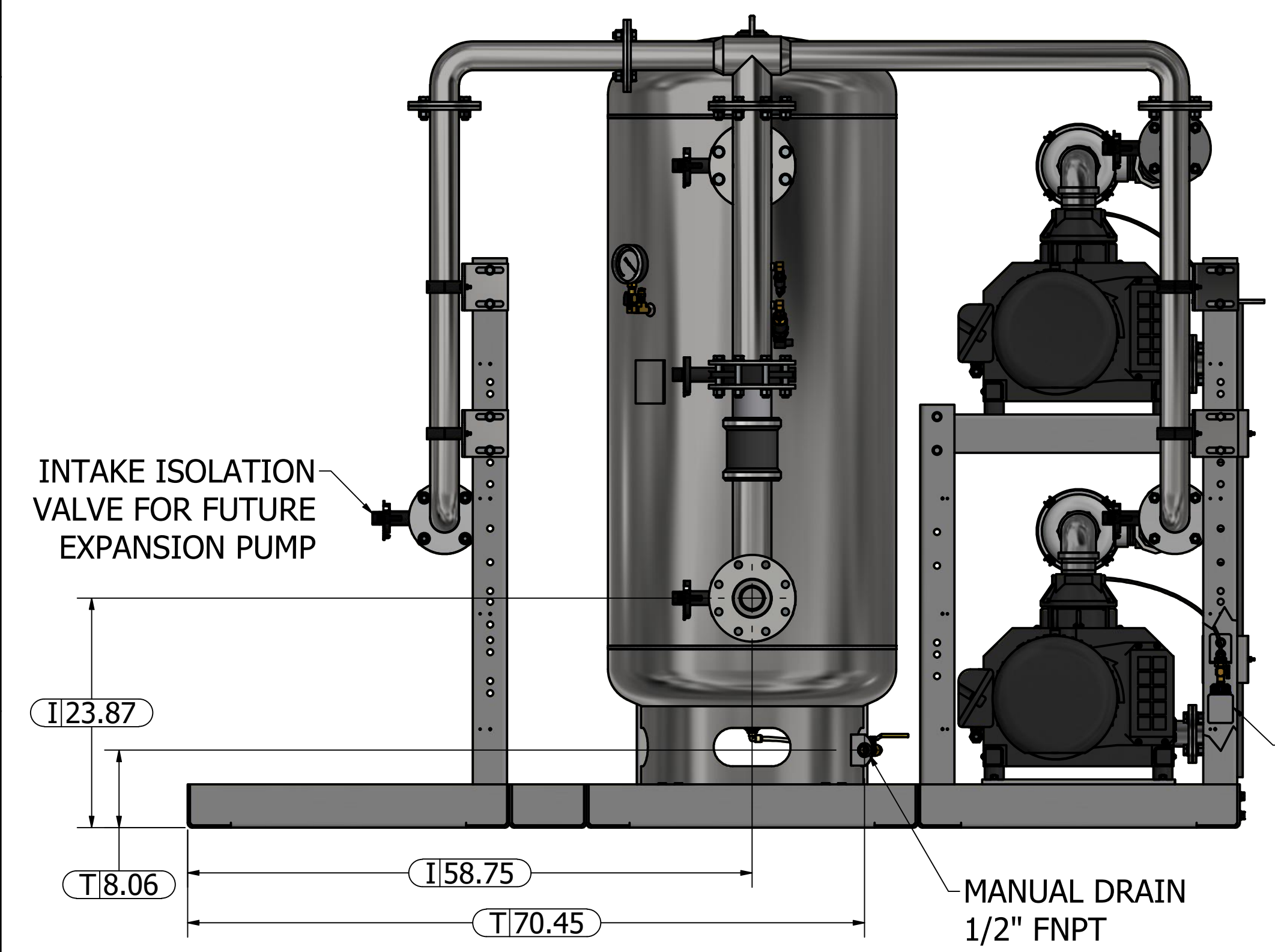
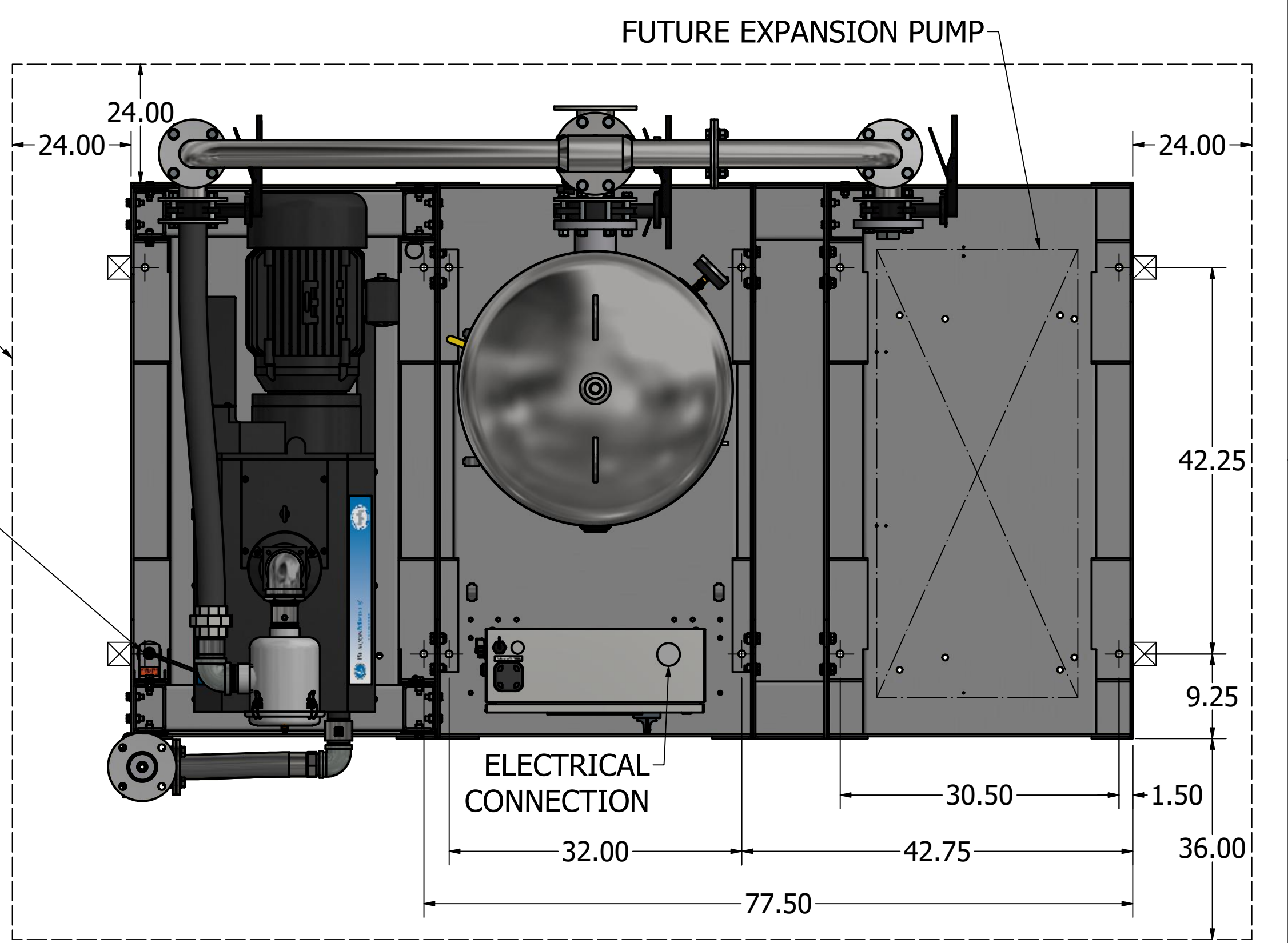

Revised: a00551998	Date: 3/29/2023	Drawn: JWO	Date: 2/11/2014
		This drawing and the information contained herein remain the property of BeaconMedaes and may not be used for other than the purpose for which it is loaned without the expressed written permission from BeaconMedaes Engineering.	
Description: GENERAL ASSEMBLY 15HP DX-EXP-TX CLAW VAC SPC 200G RECEIVER		Part Number: 4107 8549 50 Rev: 03 Sheet 1 of 1	
Scale: D		DO NOT SCALE THIS DOCUMENT	