

Notes:

- TX MODULE WEIGHT: 2,732 LBS (INCLUDES FUTURE EXPANSION PUMP)
240G TANK WEIGHT: 713 LBS
- ☒ INDICATES LIFTING POINT.
- DENOTES CENTER OF GRAVITY (INCLUDES FUTURE EXPANSION PUMP).

SYSTEM CONNECTIONS	
ID	DESCRIPTION
I	INLET LOCATION
D	DISCHARGE LOCATION
C	CONDENSATE DRAIN LOCATION
T	TANK DRAIN LOCATION

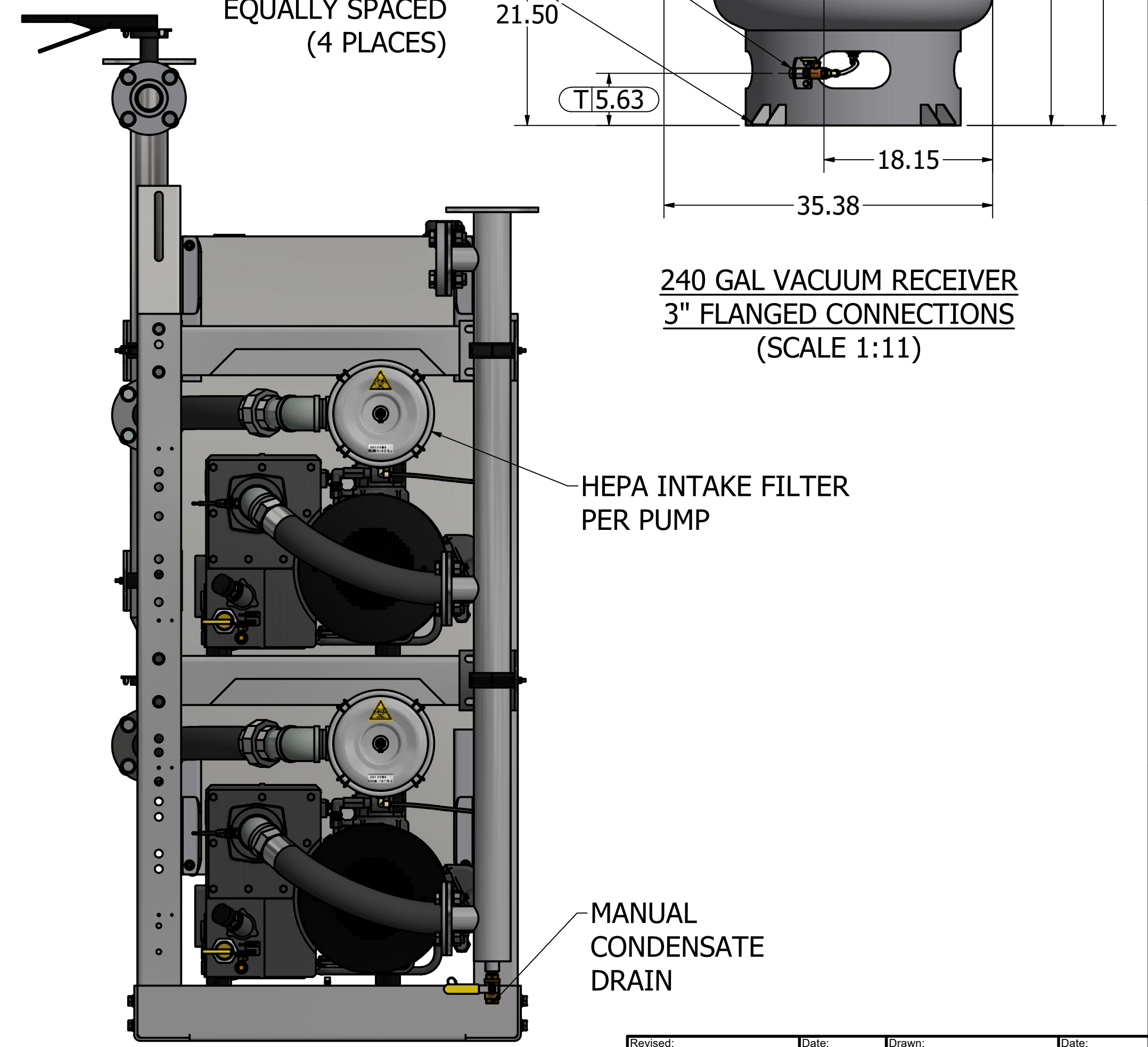
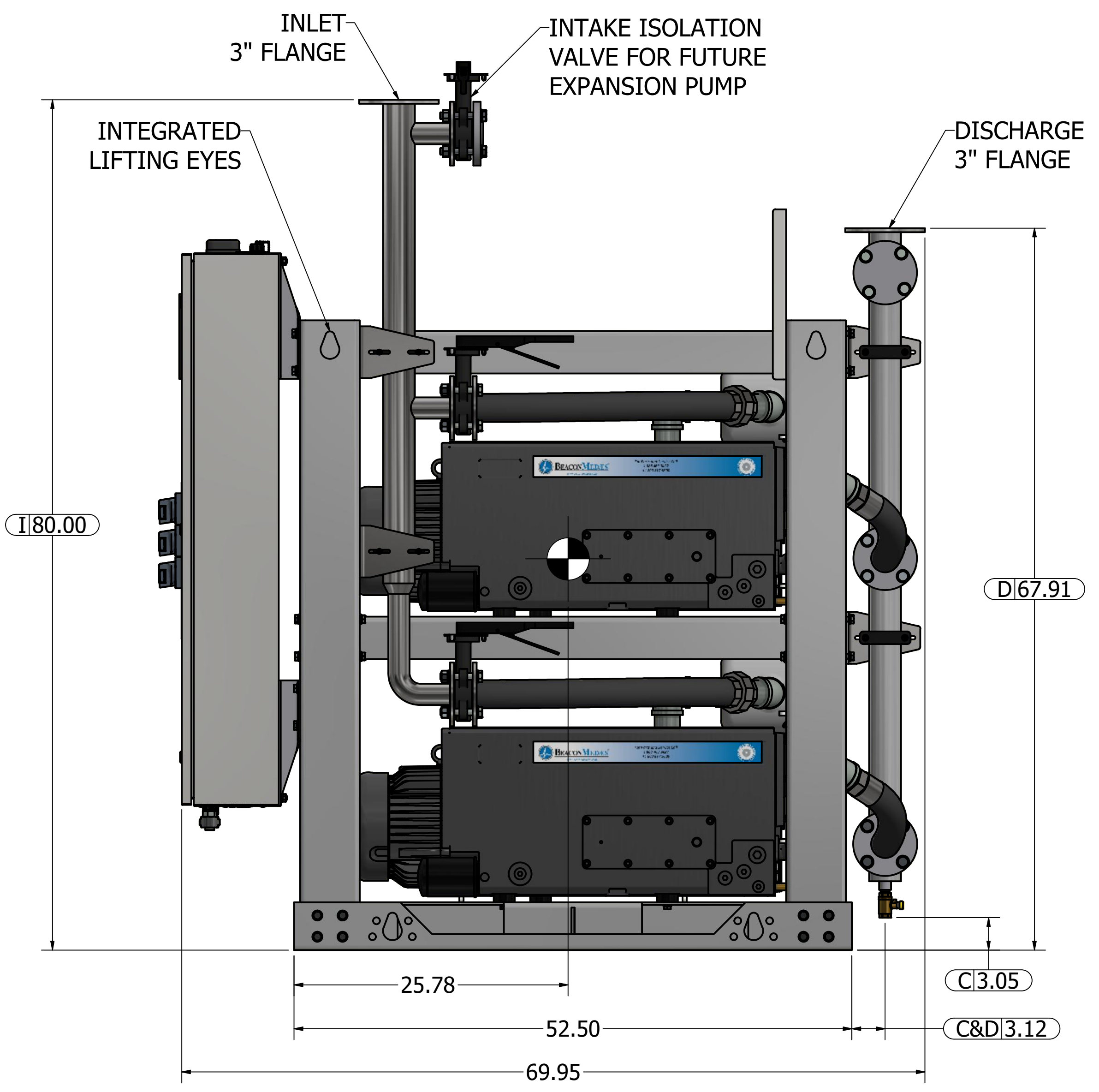
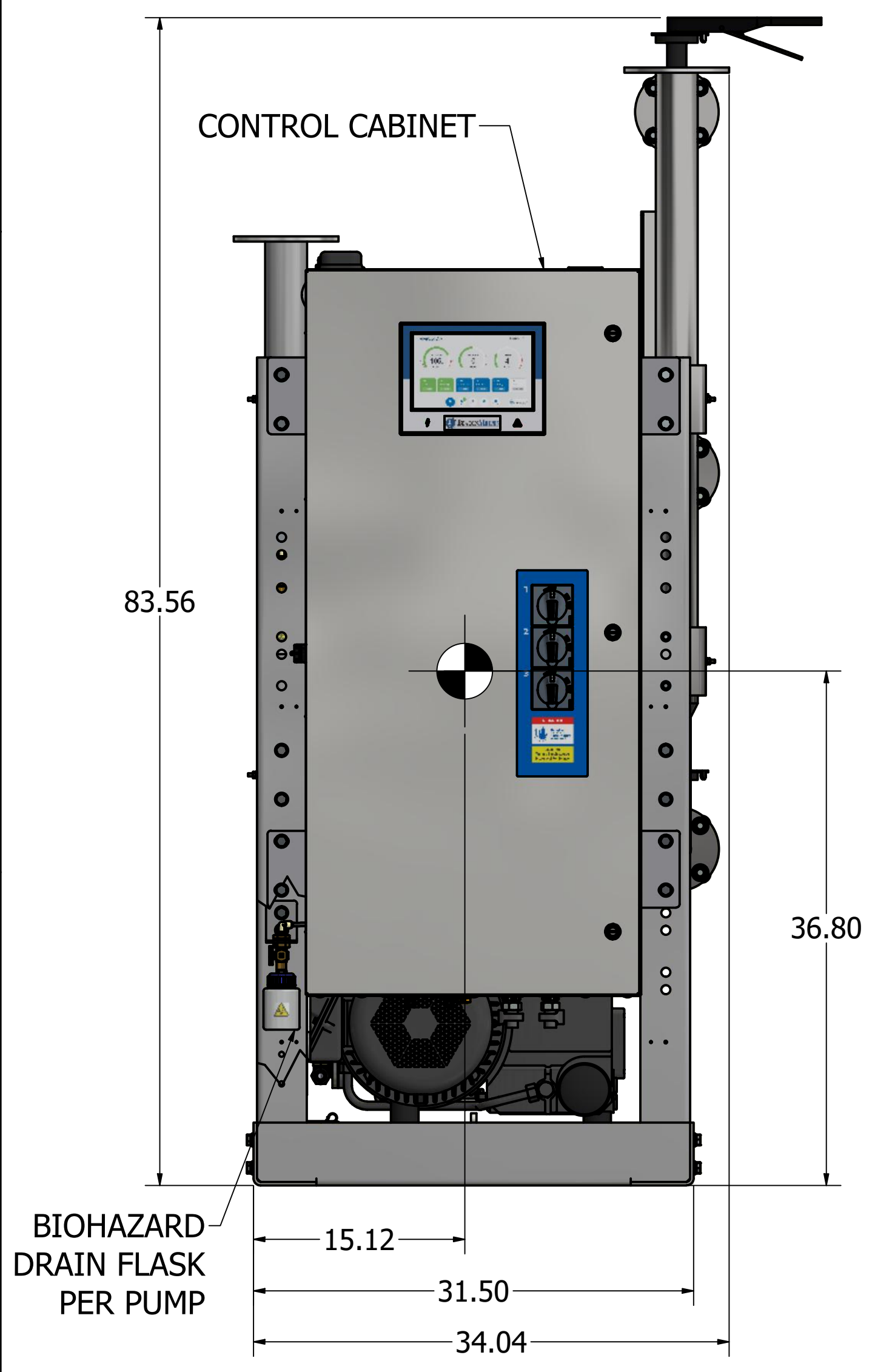
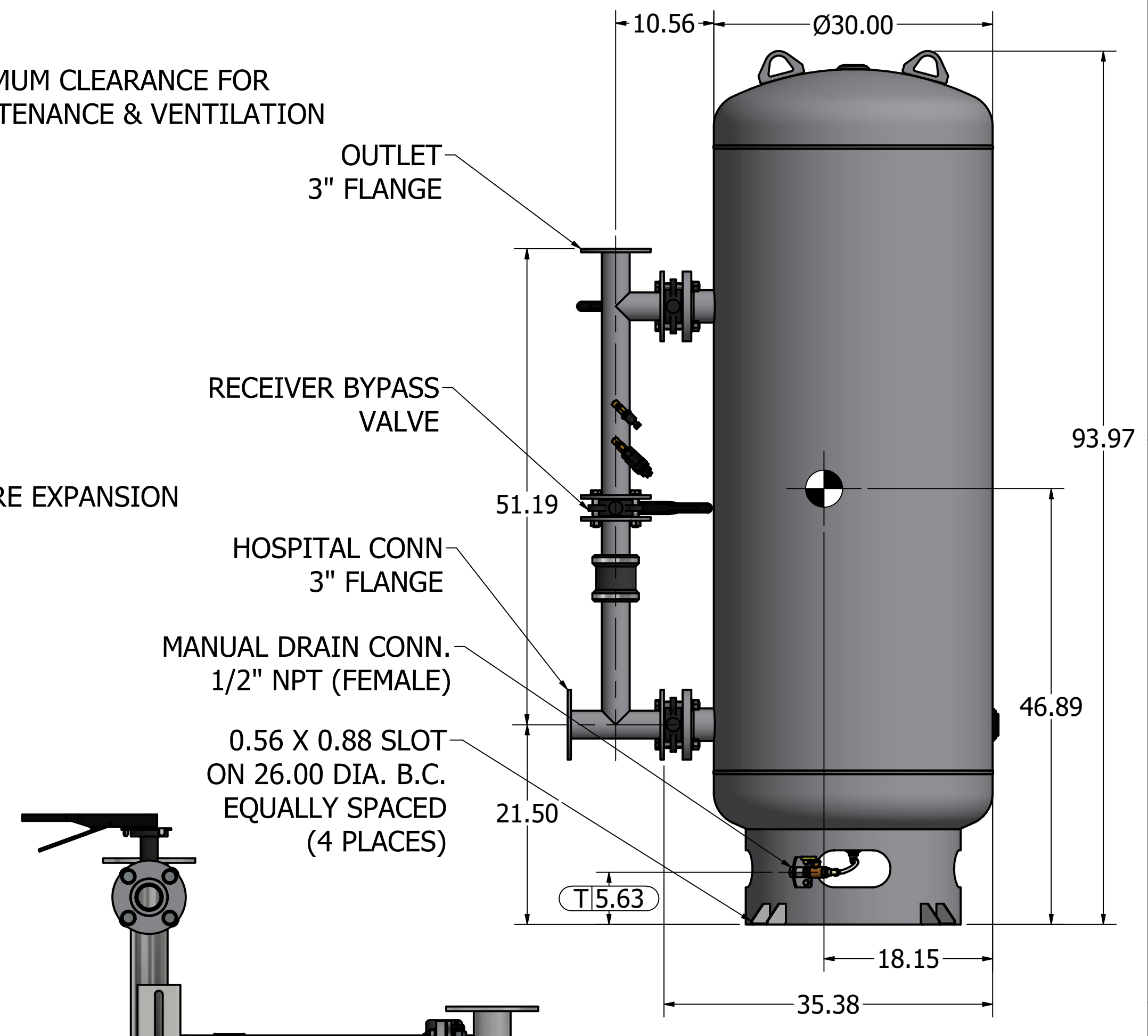
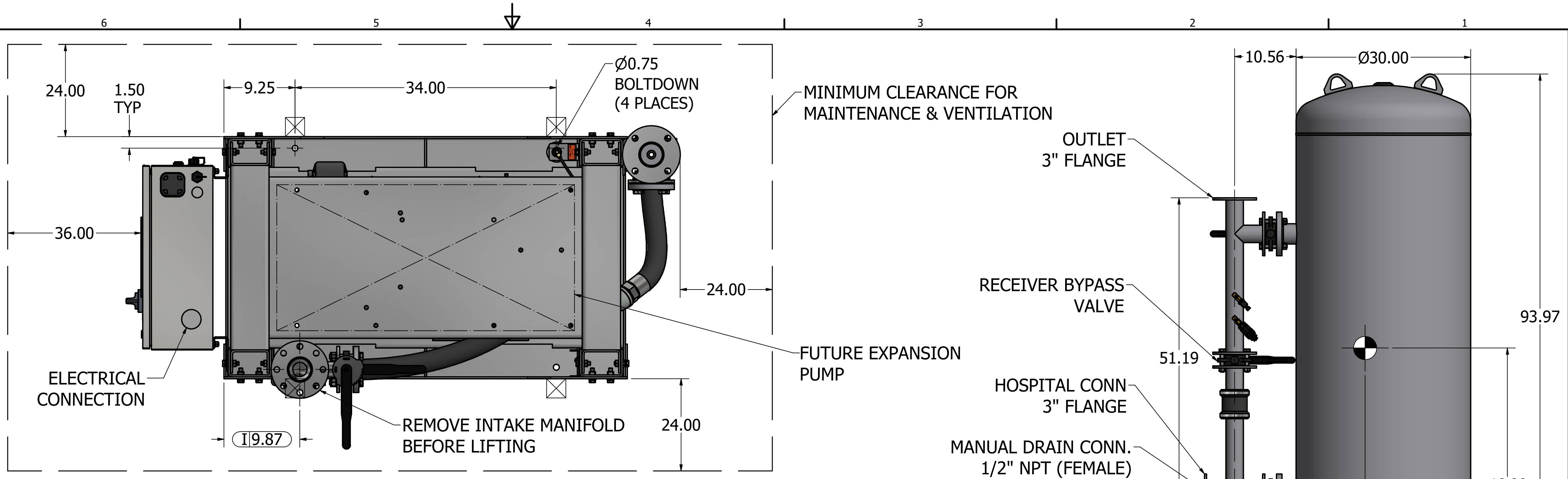

Revised: a00545201	Date: 2/13/2023	Drawn: USNKW	Date: 11/11/2010
		This drawing and the information contained therein remain the property of BeaconMedaes and may not be used for other than the purpose for which it is loaned without the expressed written permission from BeaconMedaes Engineering.	
Description: GENERAL ASSEMBLY 10HP DX-EXT-TX LUBE VAC MOD 240G RECEIVER		Part Number: 4107 8522 73	
DN: HOP230756		Rev: 03	
Sheet 1 of 1		DO NOT SCALE THIS DOCUMENT	