

Approx. mass ±110 (LBS)		Center of gravity ±2 (inch)	
Type	Pack	W	Pack
ZT15	2150	20.4	
ZT18	2194	33.0	
ZT22	2207	25.2	



Note X:
 - Dimension drawing standardized
 - Air inlet flange details added
 - Mk-IV Elektronikon changed to Mk5

Ed.	Post-Nr.	See Note X	Geveerd van / Modified from	2011-05-20	Datum / Date	Ingeveerd / Int./Appr.



Note:
 * With full open door

All materials supplied are in compliance with the requirements of the List of Prohibited Substances	
9820576700	01.12
Parent 3D model	Ed. - Version 3D

Tolerances, if not indicated, according to:		ATLAS COPCO STANDARD CLASS	
Name	DIMENS.	ZT15-22 MED	Secrecy Class
Material	NOT APPLICABLE		1121/3
Treatment	Not Applicable		INV
Scale	1:10	Family	A/Compare
Drawn by	staman,	Blank no.	Replaces
Version Dwg	02.11	Blank wt.	0 kg
Des checked.	Prod checked.	Approved.	Date
9820576700		284.217 Kg	
Approved		Designation	
		9820576700	

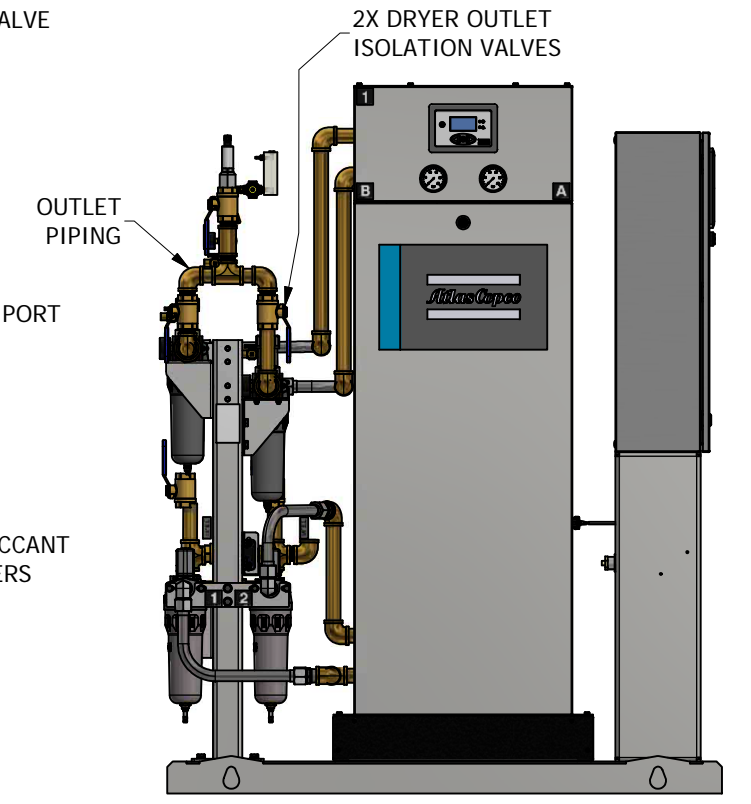
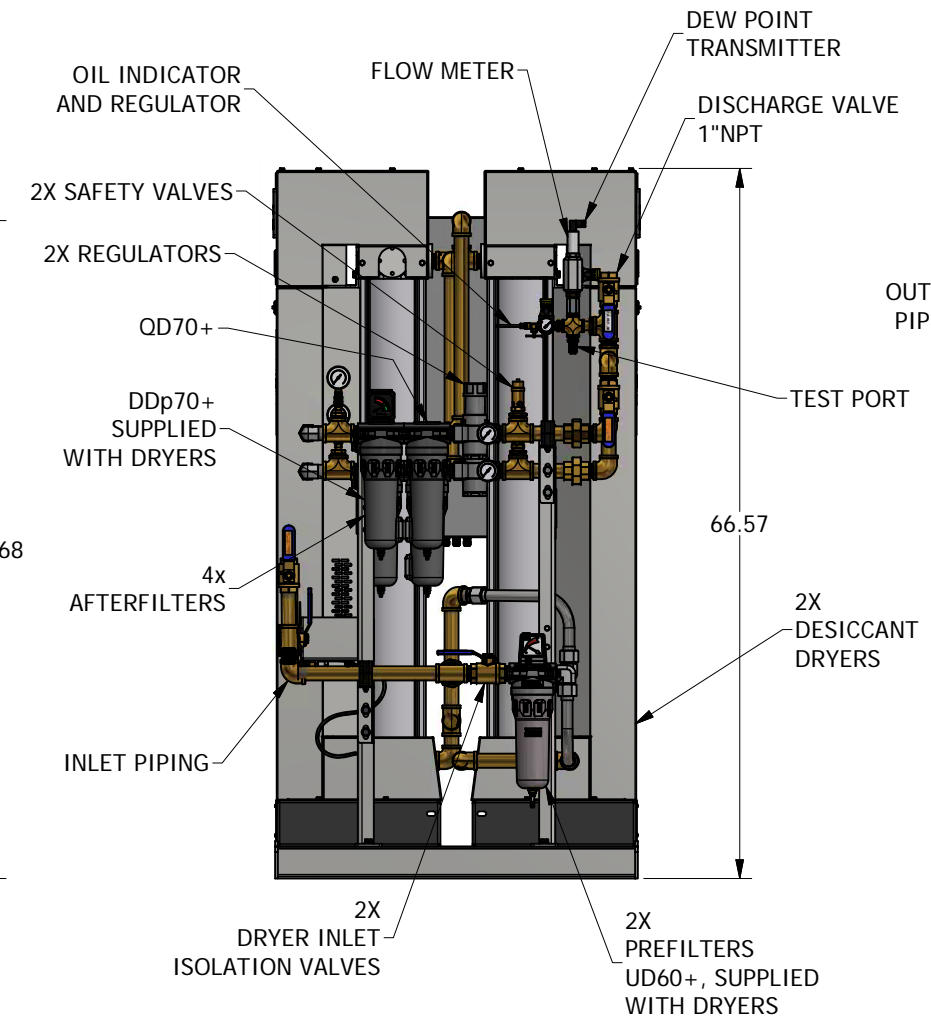
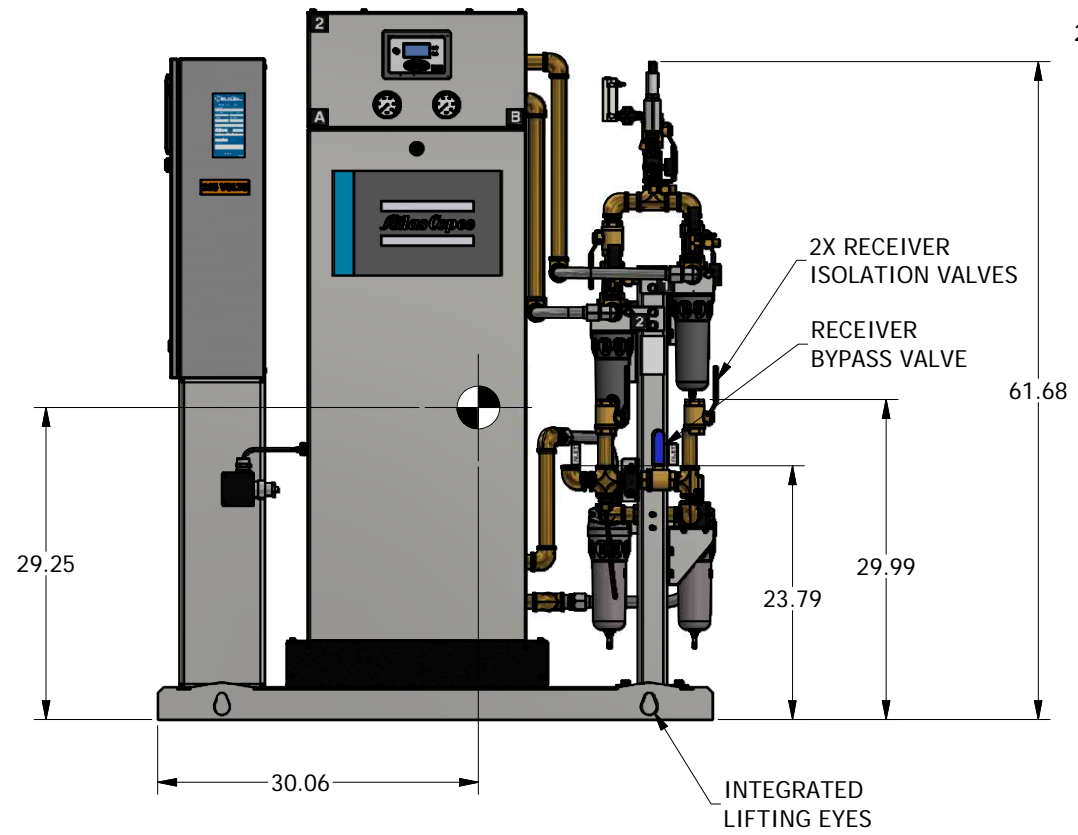
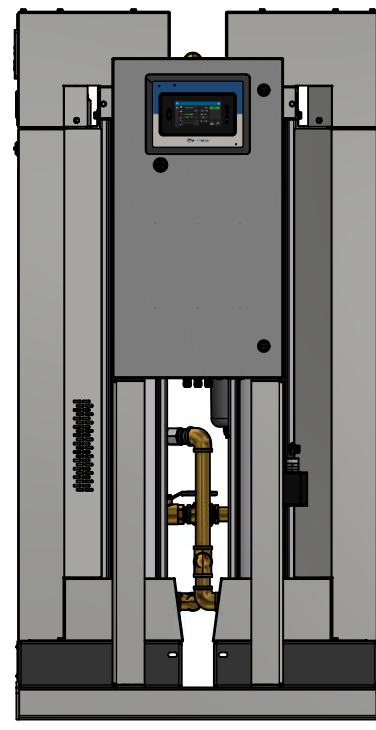
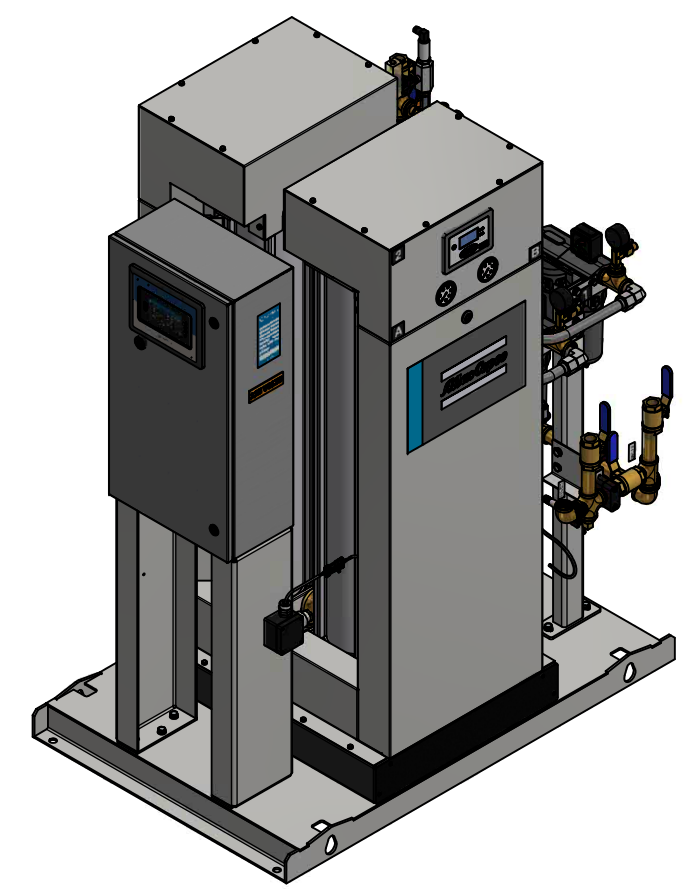
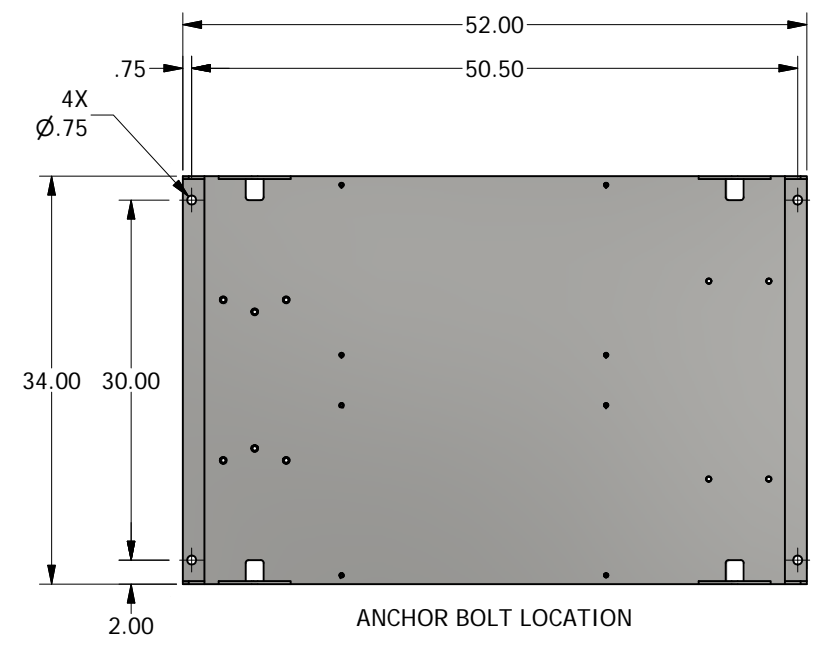
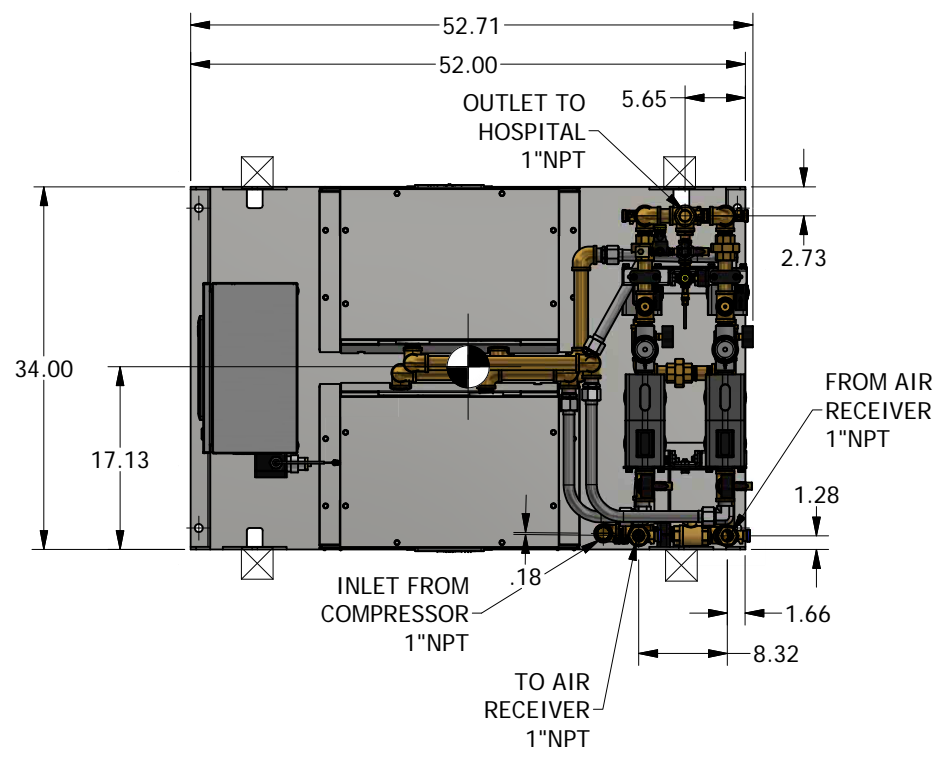
- Notes:
1. ALLOW 36 INCHES IN FRONT OF CONTROL PANEL AND 24 INCHES ON ALL OTHER SIDES OF DRYER PACKAGE FOR PROPER VENTILATION AND MAINTENANCE.
 2. SHIPPING WEIGHT: ~900 LBS.
 3. SYSTEM CAPACITY: 137 CFM.
 4.  INDICATES CENTER OF GRAVITY.
 5.  INDICATES LIFTING POINTS
 6. SEE SHEET 2 FOR DRYER INLET/OUTLET PIPING DETAILS.



Revised:	Date:	Drawn:	Date:
		MDB	9/30/2020
		This drawing and the information contained therein remain the property of BeaconMedes and may not be used for other than the purpose for which it is loaned without the expressed written permission from BeaconMedes Engineering.	
Description: GENERAL ASSEMBLY CD65 DRYER MODULE 137CFM Z-MED MEDICAL AIR SYSTEM MK5 TOUCH		Drawing Number: 4107 8563 67	Scale: 1:9 
Sheet 1 of 2		Rev: 00	DO NOT SCALE THIS DOCUMENT

- Notes:
1. ASME CODE CONSTRUCTION.
 2. DESIGN PRESSURE: 200 PSI AT 400°F.
 3. NATION BOARD REGISTERED.
 4. ALL OPENINGS ARE NPT THREADED.
 5. WEIGHT: 775 LBS (TANK) AND 22 LBS (SIGHT GLASS ASM).
 6.  DENOTES CENTER OF GRAVITY.

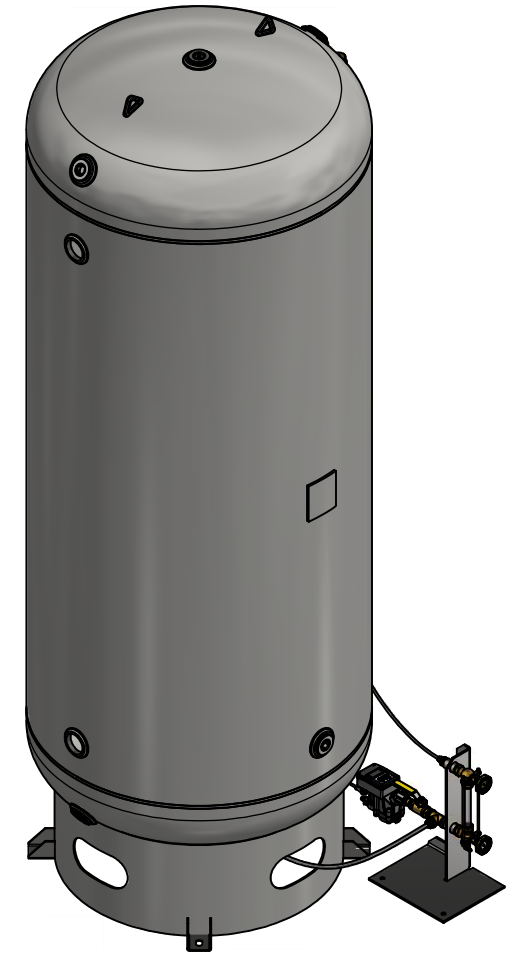
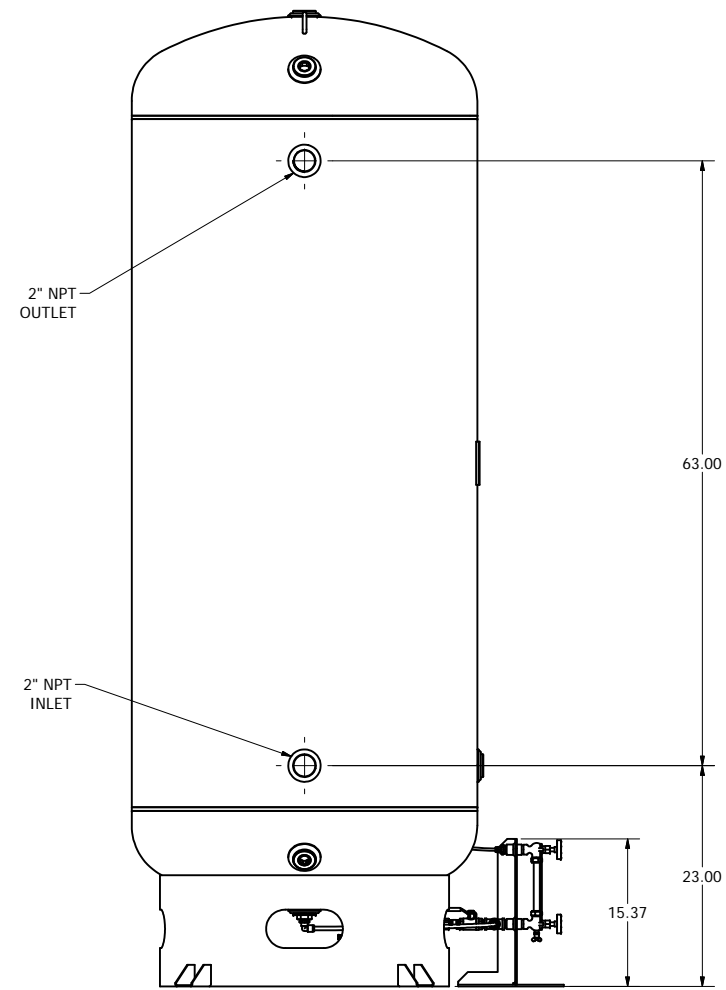
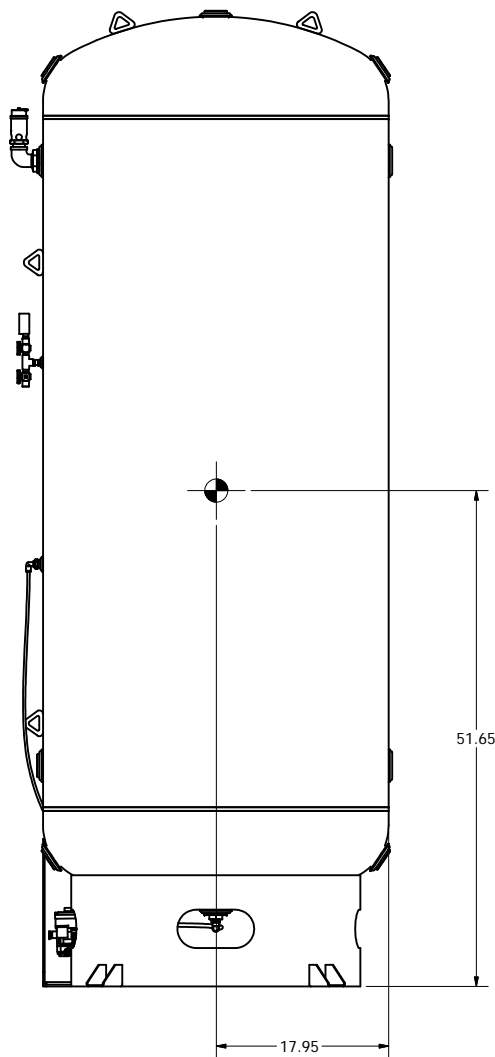
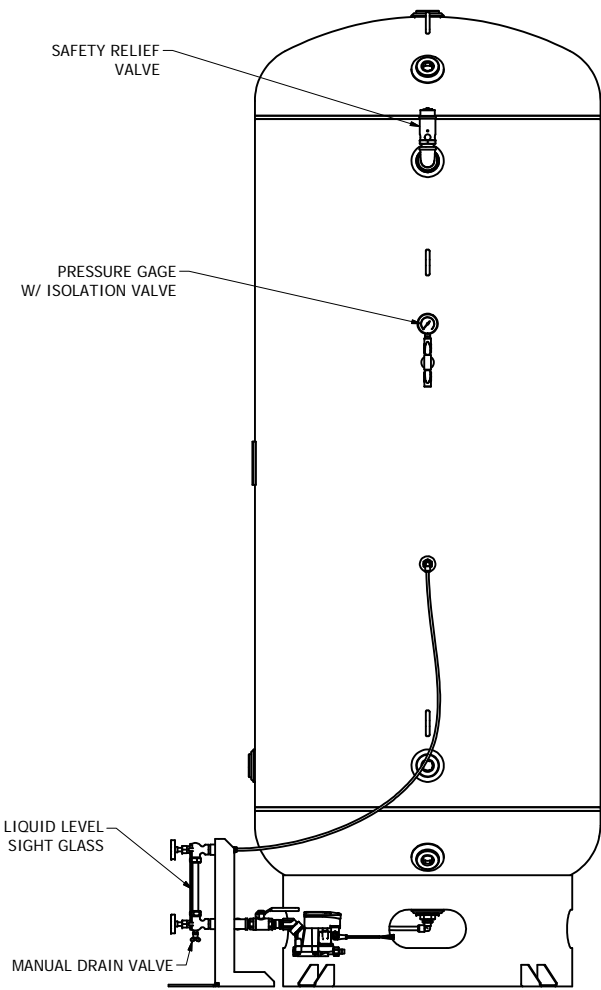
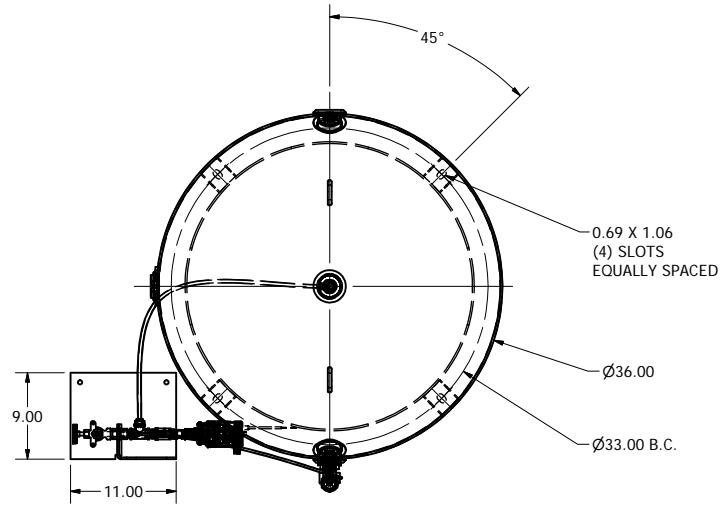

Revised:	Date:	Drawn: MDB	Date: 7/8/2021
		This drawing and the information contained therein remain the property of BeaconMedes and may not be used for other than the purpose for which it is loaned without the expressed written permission from BeaconMedes Engineering.	
Description: AIR RECEIVER TANK - 400 GALLON W/STAND ALONE SIGHT GLASS & DRAIN		Drawing Number: 4107 0082 32	Scale: 1/10
DN: HOP211010		Rev: 00	Sheet 1 of 1
		DO NOT SCALE THIS DOCUMENT	