



This drawing and the information contained thereon remain the property of BeaconMedes and may not be used for other than the purpose for which it is loaned without the expressed written permission from BeaconMedes Engineering.

- Notes:
1. SYSTEM WEIGHT: 658 LBS.
 2.  INDICATES LIFTING POINTS
 3.  DENOTES CENTER OF GRAVITY

SYSTEM CONNECTIONS	
ID	DESCRIPTION
I	INLET LOCATION
D	DISCHARGE LOCATION
T	TANK DRAIN

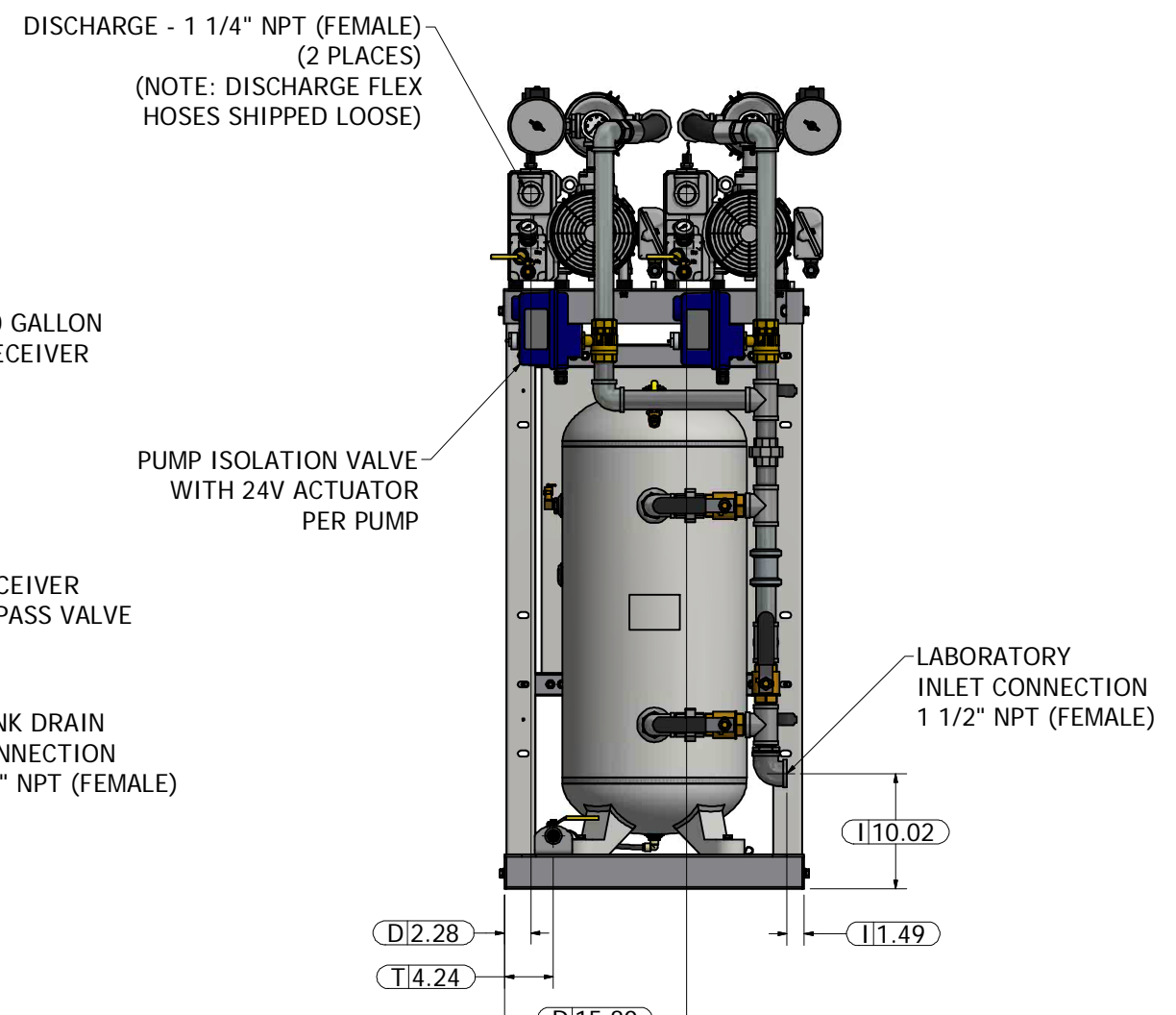
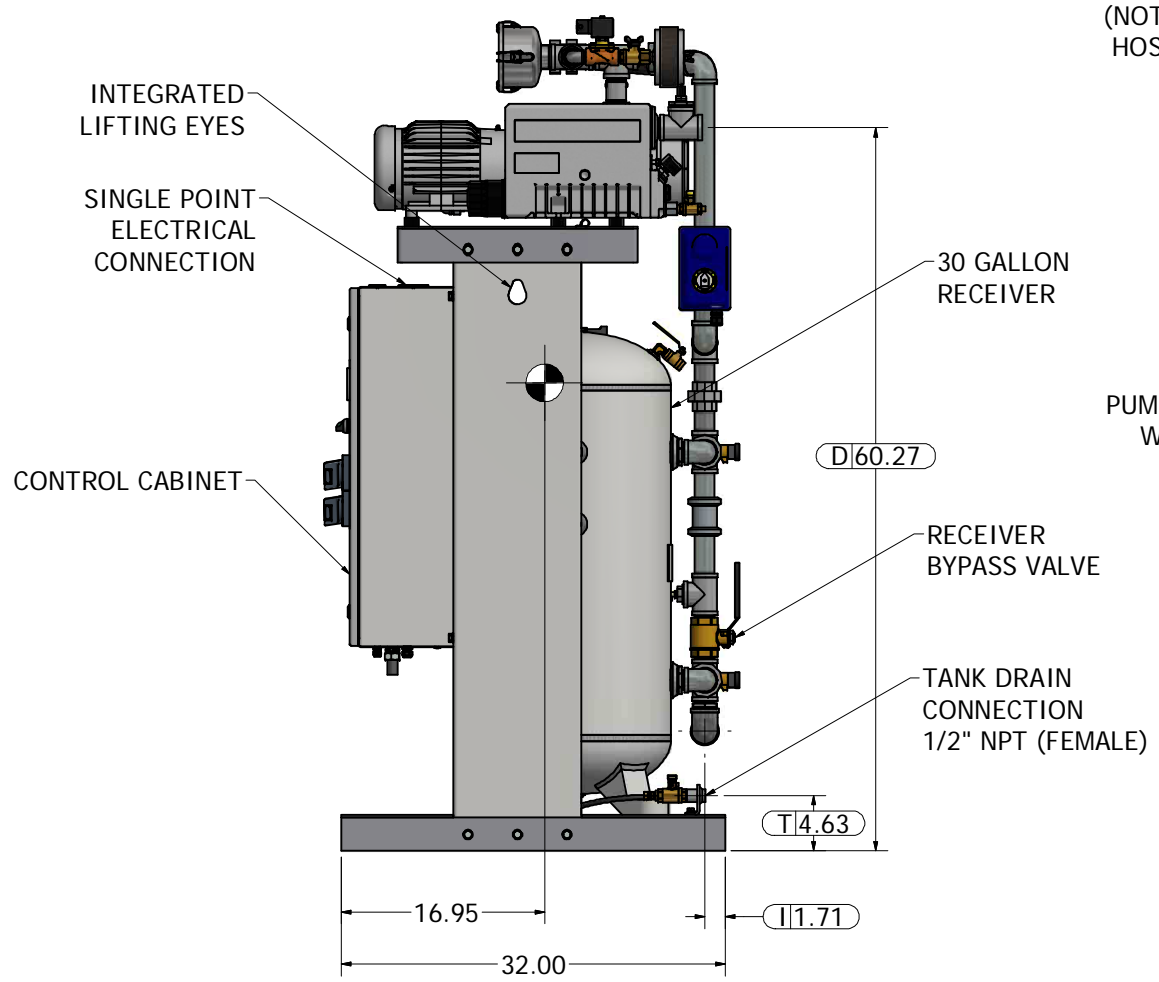
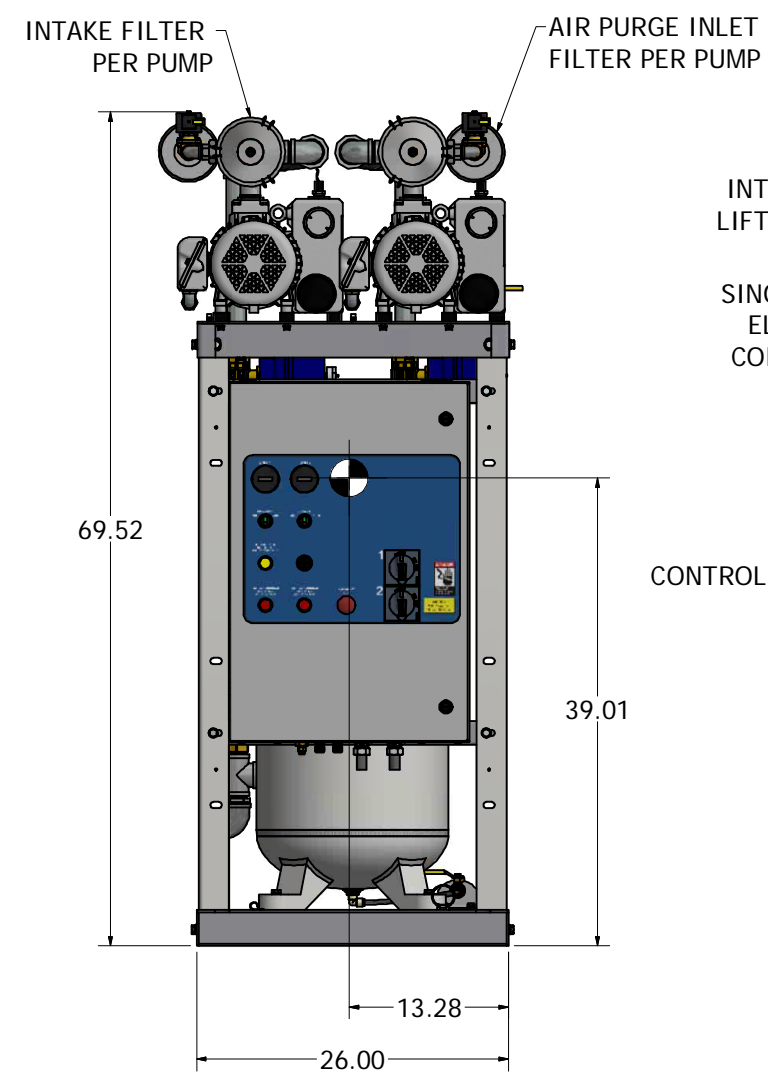
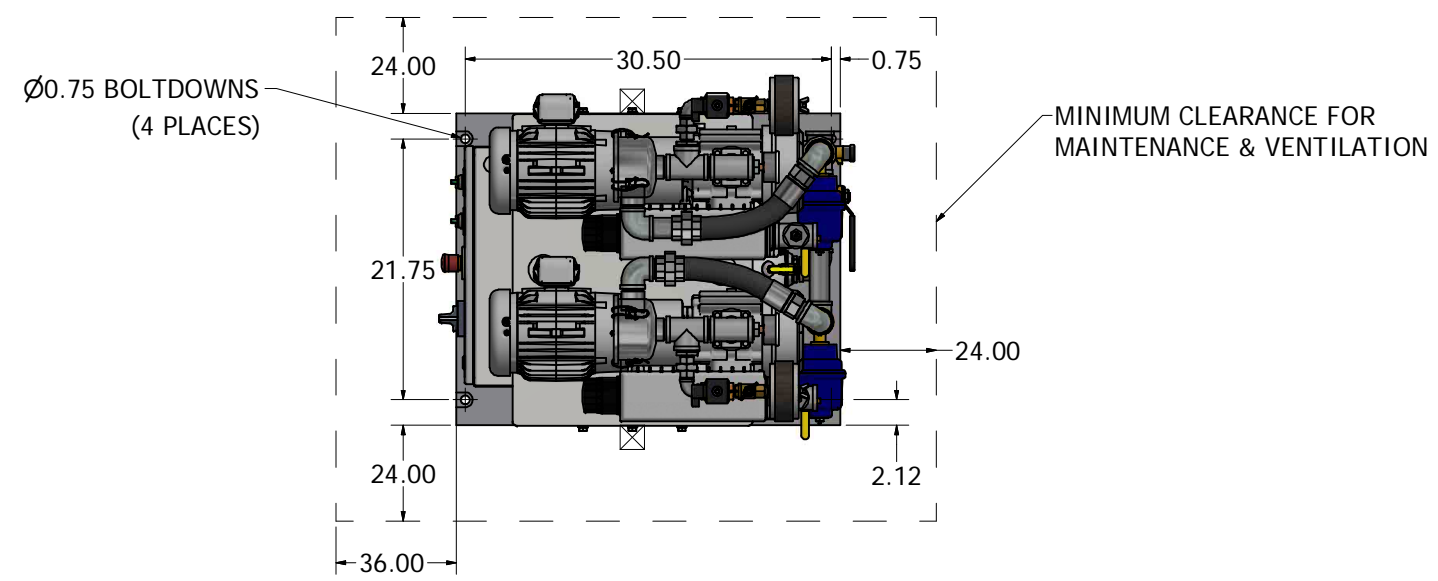

Revised: MDB	Date: 05/17/2019	Drawn: MDB	Date: 11/30/2017
INSPECTION CHECKLIST UNLESS OTHERWISE SPECIFIED:		UNLESS OTHERWISE SPECIFIED ALL DIMENSIONS ARE IN INCHES AND TOLERANCES ARE: XX ±.02 XXX ±.005 ANGLES ±.5	
Description: GENERAL ASSEMBLY DX 2HP LAB LUBE VTM V 30G BASIC		Part Number: 4107 8562 78	Scale: D
EQUIPMENT TO BE USED DURING RECEIVING INSPECTION SHALL BE PER QUALITY SYSTEM PROCEDURES		DN: BM190347	Rev: 01
Sheet 1 of 1		DO NOT SCALE THIS DOCUMENT	