

Notes:

1. THE AMPACITY OF CONDUCTORS SUPPLYING THE CONTROL PANEL TO BE ROUNDED UP TO THE NEXT SIZE LARGER STANDARD WIRE GAUGE.
2. MOP VALUES TO BE ROUNDED DOWN TO THE NEAREST STANDARD RATING OF THE OVERCURRENT PROTECTION DEVICE.
3. SHORT CIRCUIT CURRENT RATING (SCCR): 65 kA

**AUTO OPERATION:**

THE MASTER PCB WILL CONTROL THE ADAPTIVE FUNCTIONALITY OF THE SYSTEM. THE ADAPTIVE CONTROL CAUSES THE VACUUM PUMPS TO START BASED ON THE VACUUM LEVEL. THE SIGNAL TO STOP IS BASED ON THE LENGTH OF TIME THE VACUUM SYSTEM WAS NOT RUNNING. THE MASTER PCB DETERMINES THE MINIMUM RUN TIME OF A PUMP ONCE IT HAS STOPPED. IF THE VACUUM SYSTEM IS STOPPED FOR A LONG PERIOD OF TIME, THE MINIMUM RUN TIME AFTER A RESTART WILL BE SHORT. IF THE VACUUM SYSTEM IS STOPPED FOR A SHORT PERIOD OF TIME, THE MINIMUM RUN TIME WILL BE LONGER. SEE O&M MANUAL FOR SPECIFIC VARIATIONS. IF DURING OPERATION THE FOURTH VACUUM PUMP IS REQUIRED TO TURN ON, THE MASTER CONTROLLER WILL SET A LAG ALARM CONDITION.

**PUMP PCB S1 POSITION:**

**POSITION (A) – AUTO (DEFAULT):**

THE PUMP WILL OPERATE NORMALLY AS DESCRIBED ABOVE IN "AUTO OPERATION".

**POSITION (X) – OFF:**

THE PUMP IS DISABLED FROM RUNNING.

**POSITION (O) – MANUAL:**

THE PUMP WILL RUN CONTINUOUSLY.

**PCB FAULT:**

IF A PUMP PCB ETHERNET FAULT OR A TRANSDUCER FAULT OCCURS, THE PUMP PCB WILL AUTOMATICALLY SWITCH TO EMERGENCY MANUAL MODE. VACUUM PUMPS WILL START WHEN BVS-1 (BACKUP VACUUM SWITCH) CLOSSES AND STOP WHEN THE RUN TIMER EXPIRES.

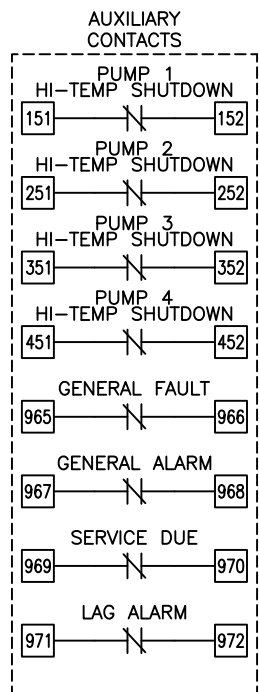

**NOTE:**  
AUXILIARY CONTACTS 151-152, 251-252, 351-352, 451-452, & 965-972 ARE "CLASS 1 CONTROL CIRCUITS. USE CLASS 1 CONDUCTORS."  
AUX CONTACTS ARE RATED 0.7A<sub>dc</sub>/0.7A<sub>rms</sub> @ 24V MAX. UNLESS OTHERWISE NOTED.  
AUX CONTACTS CLOSED DURING NORMAL OPERATION.

**MINIMUM CIRCUIT AMPACITY (MCA)**

SYSTEM HP	208 V	230 V	380 V	460 V
5.4 HP	74.5 AMPS	67.8 AMPS	43.7 AMPS	34.4 AMPS
6.4 & 7.5 HP	106.4 AMPS	96.7 AMPS	62.0 AMPS	48.8 AMPS
8.7 & 10 HP	134.4 AMPS	122.2 AMPS	79.0 AMPS	61.6 AMPS
15 HP	199.9 AMPS	181.7 AMPS	117.3 AMPS	91.3 AMPS

**MAXIMUM OVERCURRENT PROTECTION (MOP)**

SYSTEM HP	208 V	230 V	380 V	460 V
5.4 HP	87.7 AMPS	79.8 AMPS	50.9 AMPS	39.9 AMPS
6.4 & 7.5 HP	127.1 AMPS	115.5 AMPS	73.5 AMPS	57.8 AMPS
8.7 & 10 HP	161.7 AMPS	147.0 AMPS	94.5 AMPS	73.5 AMPS
15 HP	242.6 AMPS	220.5 AMPS	141.8 AMPS	110.3 AMPS

**INDIVIDUAL MOTOR NAMEPLATE FULL LOAD AMPERES**

SYSTEM HP	208 V				380V/50Hz	
	230 V	460 V	S.F.	5.1 AMPS	S.F.	
5.4 HP	12.4 AMPS	5.7 AMPS	1.25	5.1 AMPS	1.15	
6.4 HP	16.0 AMPS	7.9 AMPS	1.25	8.6 AMPS	1.15	
7.5 HP	22.0 AMPS	8.9 AMPS	1.25	9.3 AMPS	1.15	
8.7 HP	22.2 AMPS	10.6 AMPS	1.25	11.3 AMPS	1.15	
10 HP	27.2 AMPS	11.8 AMPS	1.15	10.5 AMPS	1.15	
15 HP	40.5 AMPS	17.5 AMPS	1.15	14.5 AMPS	1.15	

**QUADRAPLEX SYSTEM FULL LOAD AMPERES**

SYSTEM HP	208 V	230 V	380V/50Hz	460 V
5.4 HP	57.6 AMPS	52.9 AMPS	24.4 AMPS	26.8 AMPS
6.4 HP	72.4 AMPS	71.3 AMPS	39.6 AMPS	36.0 AMPS
7.5 HP	99.6 AMPS	80.9 AMPS	42.8 AMPS	40.8 AMPS
8.7 HP	103.2 AMPS	98.5 AMPS	53.2 AMPS	49.6 AMPS
10 HP	111.6 AMPS	96.9 AMPS	58.0 AMPS	48.8 AMPS
15 HP	164.8 AMPS	142.5 AMPS	60.0 AMPS	71.6 AMPS

**INDIVIDUAL OPERATING FULL LOAD AMPERES**

SYSTEM HP	208 V	230 V	380V/50Hz	460 V
5.4 HP	13.7 AMPS	12.6 AMPS	5.6 AMPS	6.3 AMPS
6.4 HP	17.4 AMPS	17.2 AMPS	9.4 AMPS	8.6 AMPS
7.5 HP	24.2 AMPS	19.6 AMPS	10.2 AMPS	9.8 AMPS
8.7 HP	25.1 AMPS	24.0 AMPS	12.8 AMPS	12.0 AMPS
10 HP	27.2 AMPS	23.6 AMPS	14.0 AMPS	11.8 AMPS
15 HP	40.5 AMPS	35.0 AMPS	14.5 AMPS	17.5 AMPS

**OVERLOAD SETTINGS**

SYSTEM HP	208 V	230 V	380V/50Hz	460 V
5.4 HP	15.1 AMPS	13.9 AMPS	6.2 AMPS	6.9 AMPS
6.4 HP	19.1 AMPS	18.9 AMPS	10.3 AMPS	9.5 AMPS
7.5 HP	26.6 AMPS	21.6 AMPS	11.2 AMPS	10.8 AMPS
8.7 HP	27.6 AMPS	26.4 AMPS	14.1 AMPS	13.2 AMPS
10 HP	29.9 AMPS	26.0 AMPS	15.4 AMPS	13.0 AMPS
15 HP	44.6 AMPS	38.5 AMPS	16.0 AMPS	19.3 AMPS

**FUSE SELECTION CHART (MAX FUSE SIZES SHOWN)**

SYSTEM HP	FUSES	208 V	230 V	380 V	460 V
5.4 HP	FL1/FL2/FL3	---	60 AMPS	30 AMPS	35 AMPS
6.4 HP		---	---	45 AMPS	45 AMPS
7.5 HP		---	---	50 AMPS	50 AMPS
8.7 HP		---	---	---	60 AMPS
10 HP		---	---	---	60 AMPS
15 HP	---	---	---	---	
ALL	F1/F2/F4/F5/F7/F8/F10/F11	6.0 AMPS	6.0 AMPS	6.0 AMPS	6.0 AMPS
	F3/F6/F9/F12	---	---	6.0 AMPS	6.0 AMPS
	F21-F24	2.5 AMPS	2.5 AMPS	2.5 AMPS	2.5 AMPS
	F33	1.0 AMP	1.0 AMP	1.0 AMP	1.0 AMP
	F35	0.5 AMP	0.5 AMP	0.5 AMP	0.5 AMP

FL1/FL2/FL3 ARE LITTELFUSE JTD 600V TYPE  
F1-F9 ARE LITTELFUSE KLDK 600V TYPE  
F21/F22/F23/F33/F35 ARE LITTELFUSE 2AG 250V TYPE

**DEFAULT VACUUM SETTINGS ("HgV)**

ALTITUDE	LEAD CUT-OFF		LAG CUT-ON		MAXIMUM LIMITS			MINIMUM LIMITS				
	15HP O2A		15HP O2A		15HP O2A			15HP O2A				
0-1000'	21	19	16	15	24	18	24	17	17	15	16	15
1001-2000'	20	18	16	15	23	18	23	17	17	15	16	15
2001-3000'	19	17	16	15	22	18	22	17	17	15	16	15
3001-4000'	18	17	16	15	21	18	21	17	17	15	16	15
>4000'	CONSULT FACTORY											

**RELIEF VALVE SETTINGS ("HgV)**

ALTITUDE	5.4HP			O2 ASSURED PUMPS			
	6.4-8.7HP	10-15HP		5.4HP	6.4-8.7HP	10HP	15HP
0-1000'	N/A	24	23	N/A	24	23	20
1001-2000'	N/A	23	22	N/A	23	22	19
2001-3000'	N/A	22	21	N/A	22	21	18
3001-4000'	N/A	21	20	N/A	21	20	18
>4000'	CONSULT FACTORY						

**BACKUP VACUUM SWITCH ("HgV)**

BVS-1	CUT-ON	15HP O2A
		14

Revised:	Date:	Drawn:	MDB	Date:	10/30/18
		This drawing and the information contained therein remain the property of BeaconMedics and may not be used for other than the purpose for which it is loaned without the expressed written permission from BeaconMedics Engineering.			
Description:		Part Number:			
DWG WIRING CONTROL QX CLAW 5-15HP 208-460/3/50-60, 65KA		4107 8568 45			
DN:		HOP 180863		Rev: 00	
Sheet 1 of 4		DO NOT SCALE THIS DOCUMENT			

Notes:

1. MAIN DISCONNECT PROVIDED BY OTHER.
2. FIELD WIRING TO BE COPPER RATED FOR 75°C MINIMUM.
3. - - - - - INDICATES FIELD WIRING OUTSIDE OF CABINET.

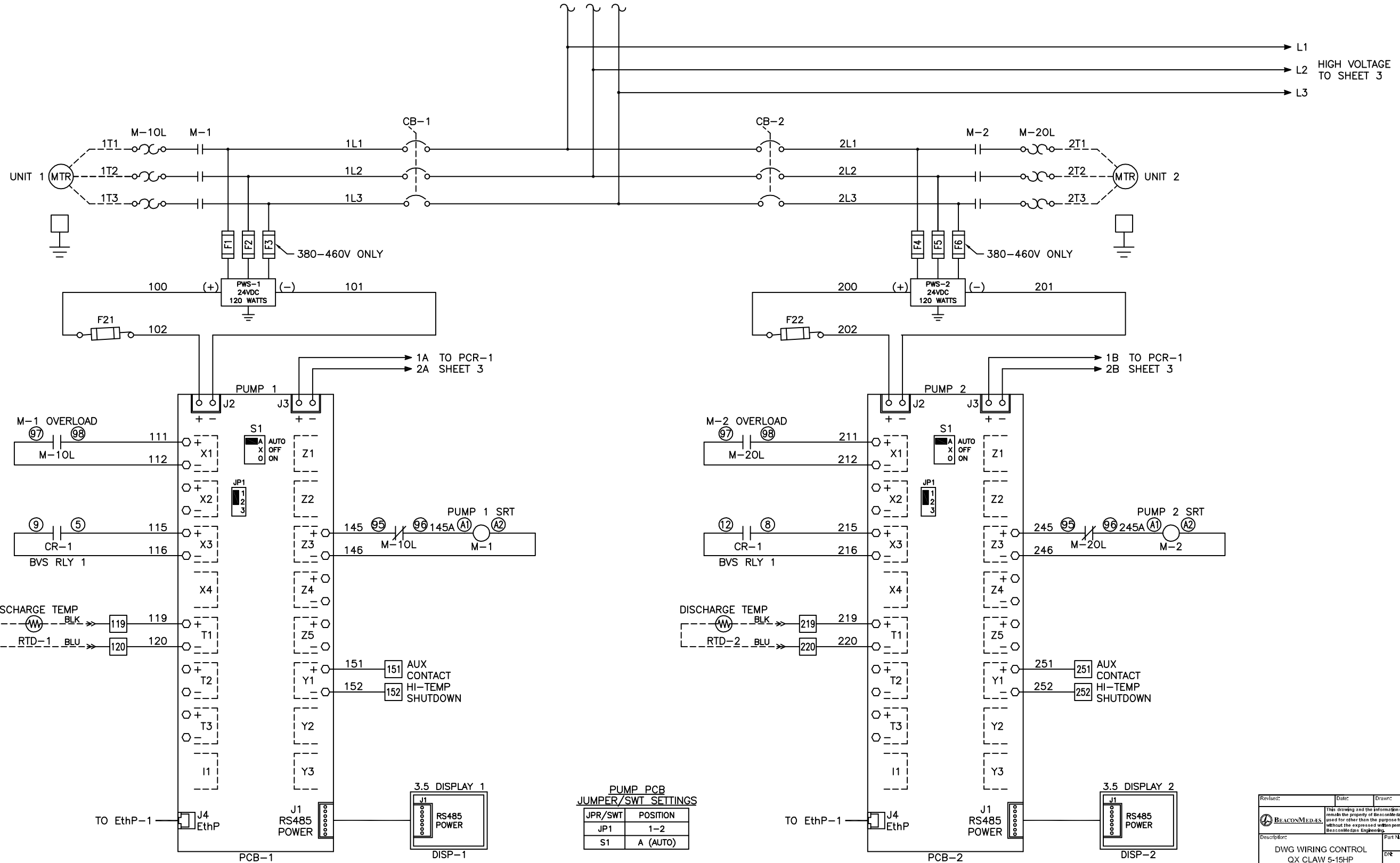
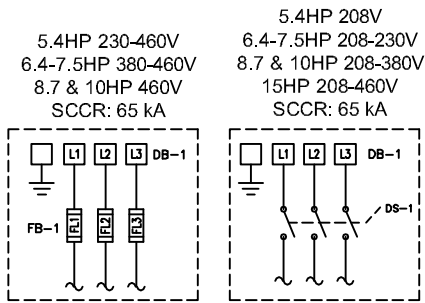

**PUMP PCB JUMPER/SWT SETTINGS**

JPR/SWT	POSITION
JP1	1-2
S1	A (AUTO)

Revised:	Date:	Drawn:	MDB	Date:	10/30/18
		<small>This drawing and the information contained herein remain the property of Beacon Medias and may not be used for other than the purpose for which it is issued without the expressed written permission from Beacon Medias Engineering.</small>			
Description: DWG WIRING CONTROL QX CLAW 5-15HP 208-460/3/50-60, 65KA			Part Number: 4107 8568 45		
Drawn: HOP 180863		Rev: 00			
Sheet 2 of 4		DO NOT SCALE THIS DOCUMENT			

Notes:

1. FIELD WIRING TO BE COPPER RATED FOR 75°C MINIMUM.
2. - - - - - INDICATES FIELD WIRING OUTSIDE OF CABINET.

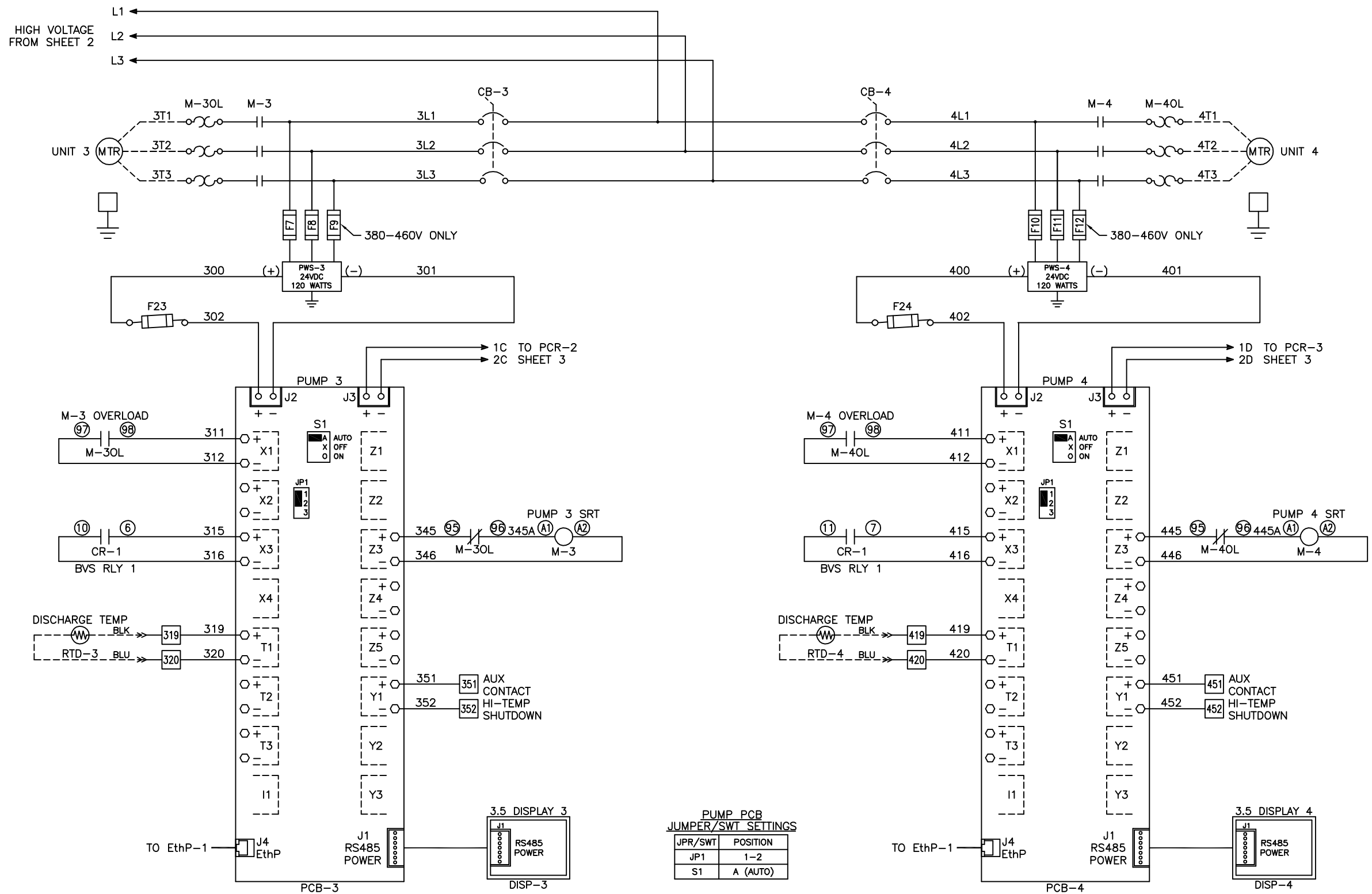

PUMP PCB JUMPER/SWT SETTINGS

JPR/SWT	POSITION
JP1	1-2
S1	A (AUTO)

Revised:	Date:	Drawn:	MDB	Date:	10/30/18
		<small>This drawing and the information contained herein remain the property of Beacon Medical and may not be used for other than the purpose for which it is issued without the expressed written permission from Beacon Medical Engineering.</small>			
Description: DWG WIRING CONTROL QX CLAW 5-15HP 208-460/3/50-60, 65KA		Part Number: 4107 8568 45 DNE HOP 180863 Sheet 3 of 4			
		Scale: NTS		Drawing Code: D Rev: 00 DO NOT SCALE THIS DOCUMENT	

Notes:

- 1. FIELD WIRING TO BE COPPER RATED FOR 75°C MINIMUM.
- 2. ----- INDICATES FIELD WIRING OUTSIDE OF CABINET.

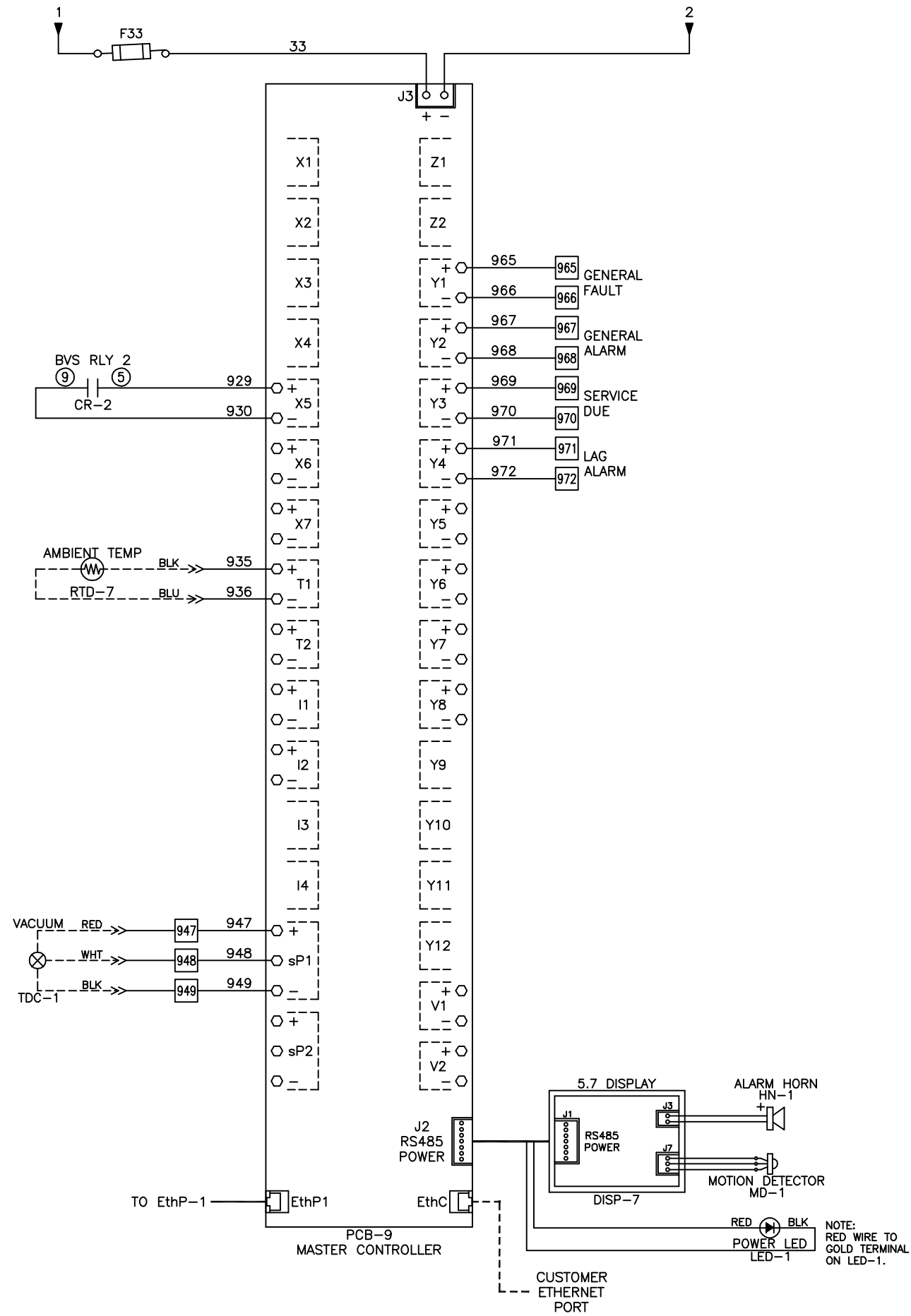
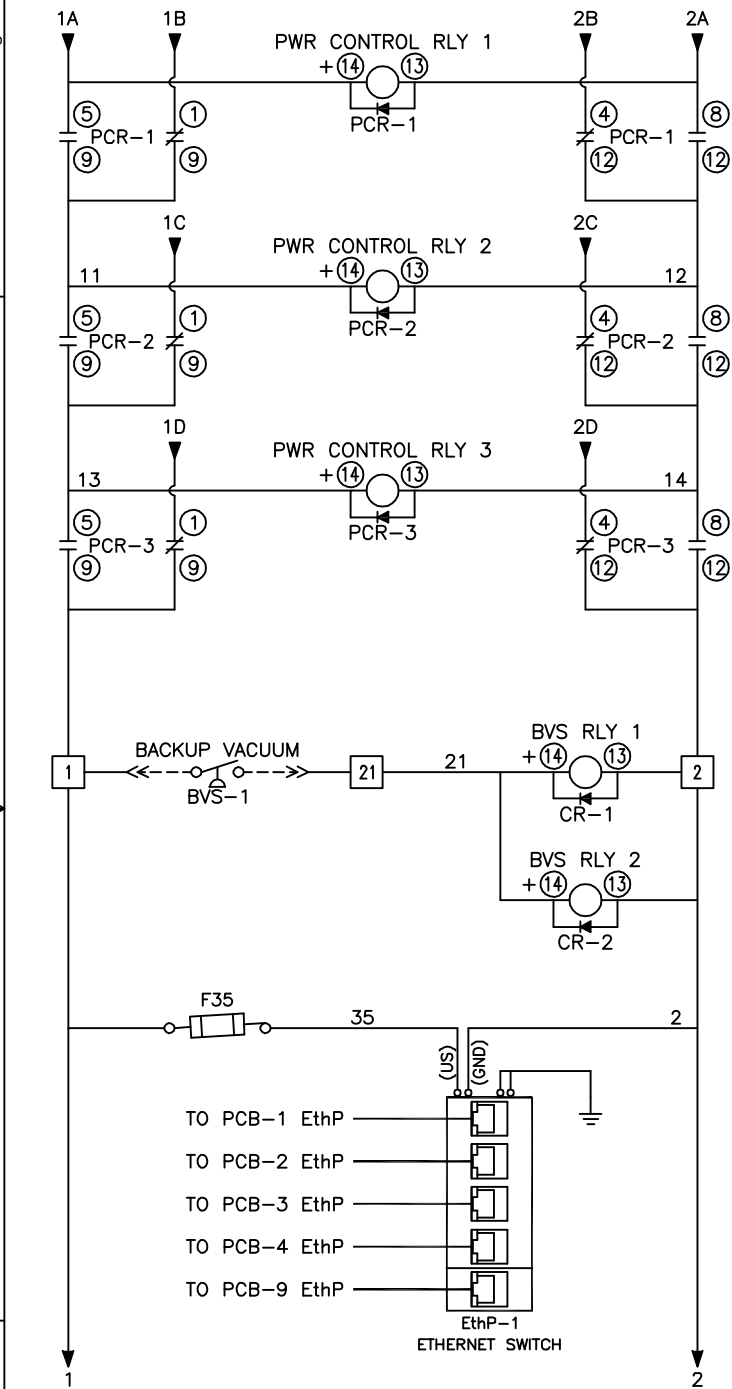

Revised:	Date:	Drawn:	MDB	Date:	10/30/18
		This drawing and the information contained therein remain the property of BeaconMedas and may not be used for other than the purpose for which it is issued without the expressed written permission from BeaconMedas Engineering.			
Description: DWG WIRING CONTROL QX CLAW 5-15HP 208-480/3/50-60, 65KA		Part Number: 4107 8568 45 Rev: 00 HOP 180863 Sheet 4 of 4 DO NOT SCALE THIS DOCUMENT			