

Notes:

1. THE AMPACITY OF CONDUCTORS SUPPLYING THE CONTROL PANEL TO BE ROUNDED UP TO THE NEXT SIZE LARGER STANDARD WIRE GAUGE.
2. MOP VALUES TO BE ROUNDED DOWN TO THE NEAREST STANDARD RATING OF THE OVERCURRENT PROTECTION DEVICE.
3. SHORT CIRCUIT CURRENT RATING (SCCR): 65 kA

AUTO OPERATION:

DURING NORMAL OPERATION THE MASTER PCB WILL SIGNAL THE LEAD VACUUM PUMP TO START WHEN THE VACUUM FALLS BELOW THE SET-POINT. IF ONE PUMP CAN CARRY THE LOAD, THEN THE VACUUM WILL RISE TO THE SET-POINT. THE PUMP PCB WILL THEN TURN OFF THE LEAD VACUUM PUMP WHEN ITS RUN TIMER EXPIRES. WHEN THE SYSTEM VACUUM FALLS AGAIN, THE MASTER PCB WILL SEQUENCE THE LEAD ROLE TO THE NEXT PUMP PCB AND IT WILL START. IF DURING OPERATION THE SYSTEM VACUUM FALLS BELOW 15"Hg, THE LAG PUMP WILL START AND A LAG ALARM WILL OCCUR.

PUMP PCB S1 POSITION:

POSITION (A) – AUTO (DEFAULT):

THE PUMP WILL OPERATE NORMALLY AS DESCRIBED ABOVE IN "AUTO OPERATION".

POSITION (X) – OFF:

THE PUMP IS DISABLED FROM RUNNING.

POSITION (O) – MANUAL:

THE PUMP WILL RUN CONTINUOUSLY.

PCB FAULT:

IF A PUMP PCB ETHERNET FAULT OR A TRANSDUCER FAULT OCCURS, THE PUMP PCB WILL AUTOMATICALLY SWITCH TO EMERGENCY MANUAL MODE. VACUUM PUMPS WILL START WHEN BVS-1 (BACKUP VACUUM SWITCH) CLOSSES AND STOP WHEN BVS-1 OPENS AND THE RUN TIMER EXPIRES.

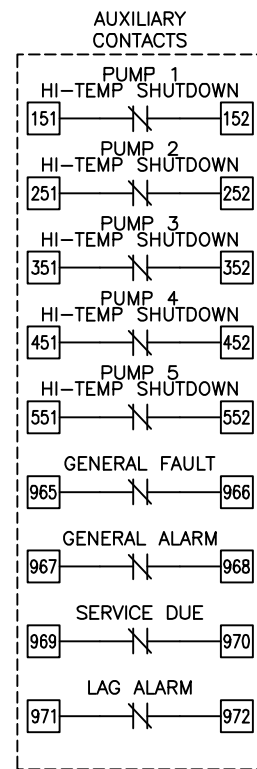

NOTE:
AUXILIARY CONTACTS 151-152, 251-252, 351-352, 451-452, 551-552, & 965-972 ARE "CLASS 1 CONTROL CIRCUITS. USE CLASS 1 CONDUCTORS."

AUX CONTACTS ARE RATED 0.7A_{dc}/0.7A_{rms} @ 24V MAX. UNLESS OTHERWISE NOTED.

AUX CONTACTS CLOSED DURING NORMAL OPERATION.

INDIVIDUAL MOTOR NAMEPLATE FULL LOAD AMPERES

SYSTEM HP	208 V	230 V	460 V	S.F.	380V/50Hz	S.F.
15 HP	40.5 AMPS	35.0 AMPS	17.5 AMPS	1.15	14.5 AMPS	1.15

MINIMUM CIRCUIT AMPACITY (MCA)

SYSTEM HP	208 V	230 V	380 V	460 V
15 HP	246.9 AMPS	224.4 AMPS	144.9 AMPS	112.8 AMPS

MAXIMUM OVERCURRENT PROTECTION (MOP)

SYSTEM HP	208 V	230 V	380 V	460 V
15 HP	288.8 AMPS	262.5 AMPS	168.8 AMPS	131.3 AMPS

INDIVIDUAL OPERATING FULL LOAD AMPERES

SYSTEM HP	208 V	230 V	380V/50Hz	460 V
15 HP	40.5 AMPS	35.0 AMPS	14.5 AMPS	17.5 AMPS

PENTAPLEX SYSTEM FULL LOAD AMPERES

SYSTEM HP	208 V	230 V	380V/50Hz	460 V
15 HP	206.0 AMPS	178.2 AMPS	75.0 AMPS	89.6 AMPS

FUSE SELECTION CHART (MAX FUSE SIZES SHOWN)

FUSES	208 V	230 V	380 V	460 V
F1/F2/F4/F5/ F7/F8/F10/ F11/F13/F14	6.0 AMPS	6.0 AMPS	6.0 AMPS	6.0 AMPS
F3/F6/F9/ F12/F15	---	---	6.0 AMPS	6.0 AMPS
F21-F25	2.5 AMPS	2.5 AMPS	2.5 AMPS	2.5 AMPS
F33	1.0 AMP	1.0 AMP	1.0 AMP	1.0 AMP
F34	0.4 AMP	0.4 AMP	0.4 AMP	0.4 AMP
F35	0.5 AMP	0.5 AMP	0.5 AMP	0.5 AMP

F1-F15 ARE LITTELFUSE KLDR 600V TYPE
F21-F25/F33-F35 ARE LITTELFUSE 2AG 250V TYPE

OVERLOAD SETTINGS

SYSTEM HP	208 V	230 V	380V/50Hz	460 V
15 HP	44.6 AMPS	38.5 AMPS	16.0 AMPS	19.3 AMPS

DEFAULT VACUUM SETPOINT ("HgV)

ALTITUDE	O2 ASSURED	
0-1000'	20	18
1001-2000'	19	17
2001-3000'	18	16
3001-4000'	17	16
>4000'	CONSULT FACTORY	

RELIEF VALVE SETTINGS ("HgV)

ALTITUDE	O2 ASSURED PUMPS	
0-1000'	23	20
1001-2000'	22	19
2001-3000'	21	18
3001-4000'	20	18
>4000'	CONSULT FACTORY	

BACKUP VACUUM SWITCH ("HgV)

BVS-1	CUT-ON	O2A	
		15	14

Revised:	Date:	Drawn:	MDB	Date:	10/30/18
		<small>This drawing and the information contained therein remain the property of BeaconMedias and may not be used for other than the purpose for which it is issued without the expressed written permission from BeaconMedias Engineering.</small>			
Description: DWG WIRING CONTROL PX CLAW VSD 15HP 208-460/3/50-60, 65kA		Part Number: 4107 8568 51		Scale: NTS D	
DWG: HOP 180863		Rev: 00		Sheet 1 of 5 DO NOT SCALE THIS DOCUMENT	

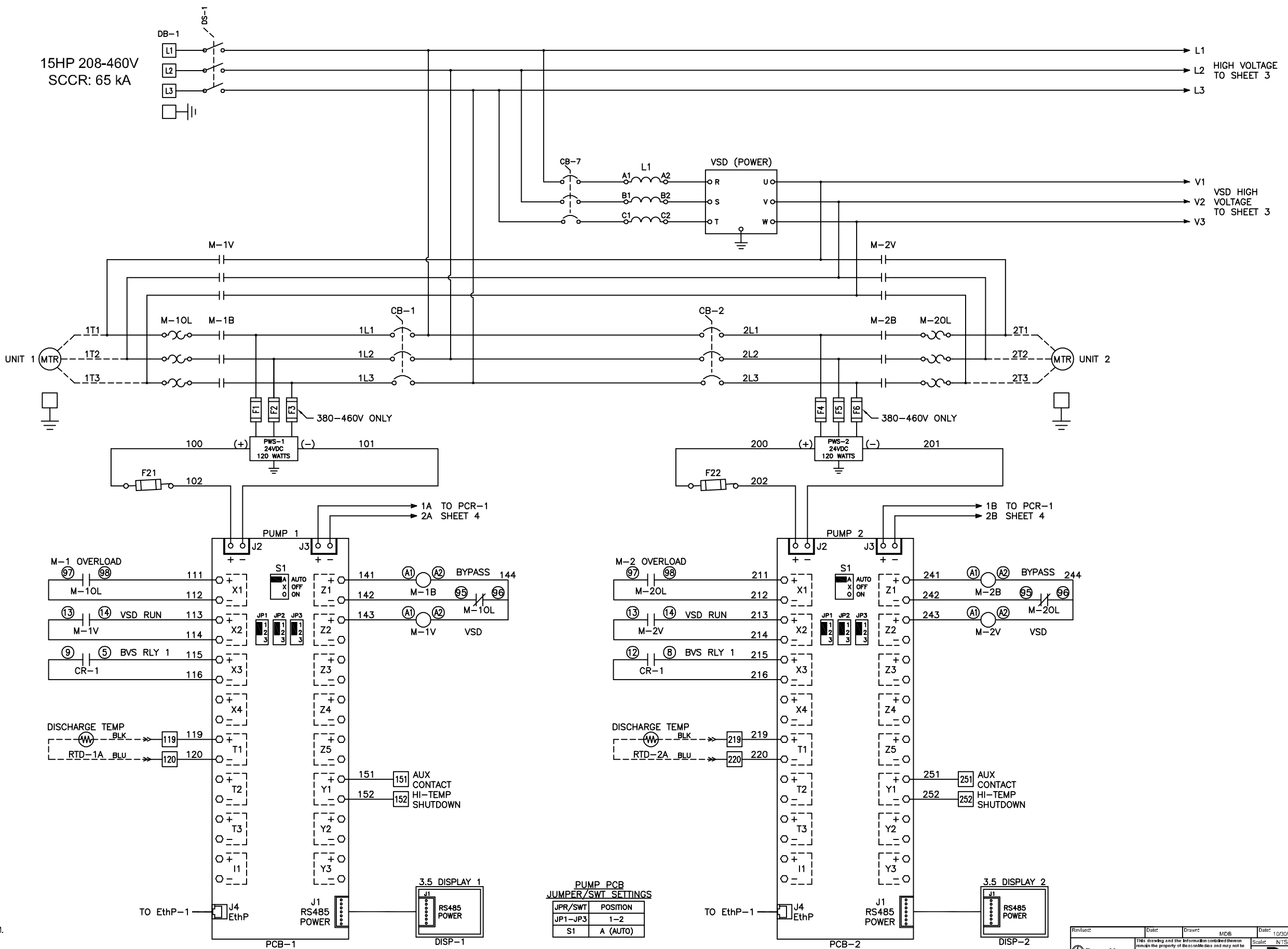

Notes:
 1. MAIN DISCONNECT PROVIDED BY OTHER.
 2. FIELD WIRING TO BE COPPER RATED FOR 75°C MINIMUM.
 3. ----- INDICATES FIELD WIRING OUTSIDE OF CABINET.

PUMP PCB JUMPER/SWT SETTINGS

JPR/SWT	POSITION
JP1-JP3	1-2
S1	A (AUTO)

Revised:	Date:	Drawn:	MDB	Date:	10/30/18
		<small>This drawing and the information contained therein remain the property of Beacon Medias and may not be used for other than the purpose for which it is issued without the expressed written permission from Beacon Medias Engineering.</small>			
Description: DWG WIRING CONTROL PX CLAW VSD 15HP 208-460/3/50-60, 65KA		Part Number: 4107 8568 51		Rev: HOP 180863 00	
Sheet 2 of 5			DO NOT SCALE THIS DOCUMENT		

Notes:

1. FIELD WIRING TO BE COPPER RATED FOR 75°C MINIMUM.
2. - - - - - INDICATES FIELD WIRING OUTSIDE OF CABINET.

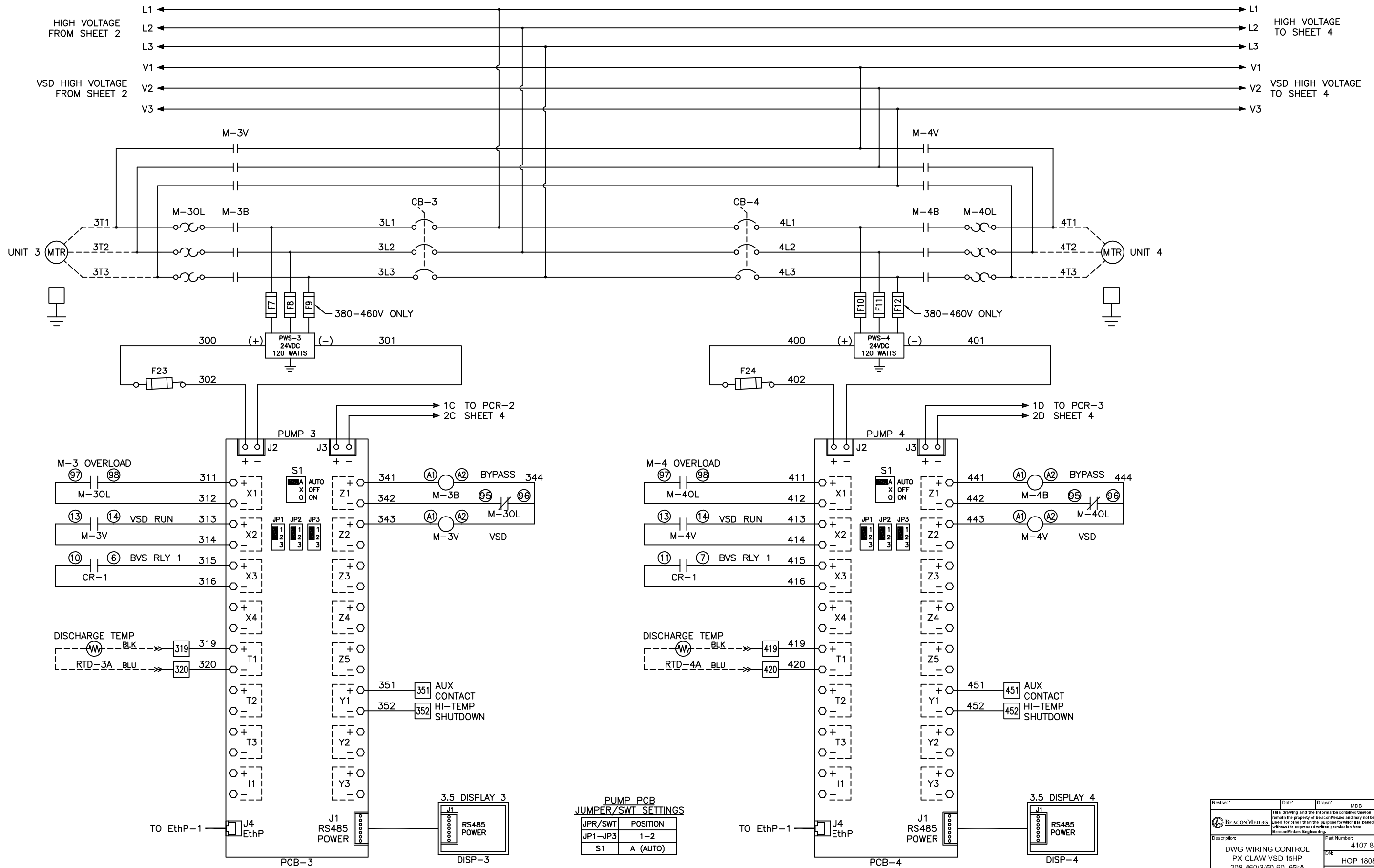

PUMP PCB JUMPER/SWT SETTINGS

JPR/SWT	POSITION
JP1-JP3	1-2
S1	A (AUTO)

Revised:	Date:	Drawn:	MDB	Date:	10/30/16
		This drawing and the information contained therein remain the property of BeaconMedics and may not be used for other than the purpose for which it is issued without the express written permission from BeaconMedics Engineering.			
Description: DWG WIRING CONTROL PX CLAW VSD 15HP 208-460/3/50-60, 65kA		Part Number: 4107 8568 51		Scale: NTS	
DNE HOP 180863		Rev: 00		Sheet 3 of 5 DO NOT SCALE THIS DOCUMENT	

Notes:

1. FIELD WIRING TO BE COPPER RATED FOR 75°C MINIMUM.
2. - - - - - INDICATES FIELD WIRING OUTSIDE OF CABINET.

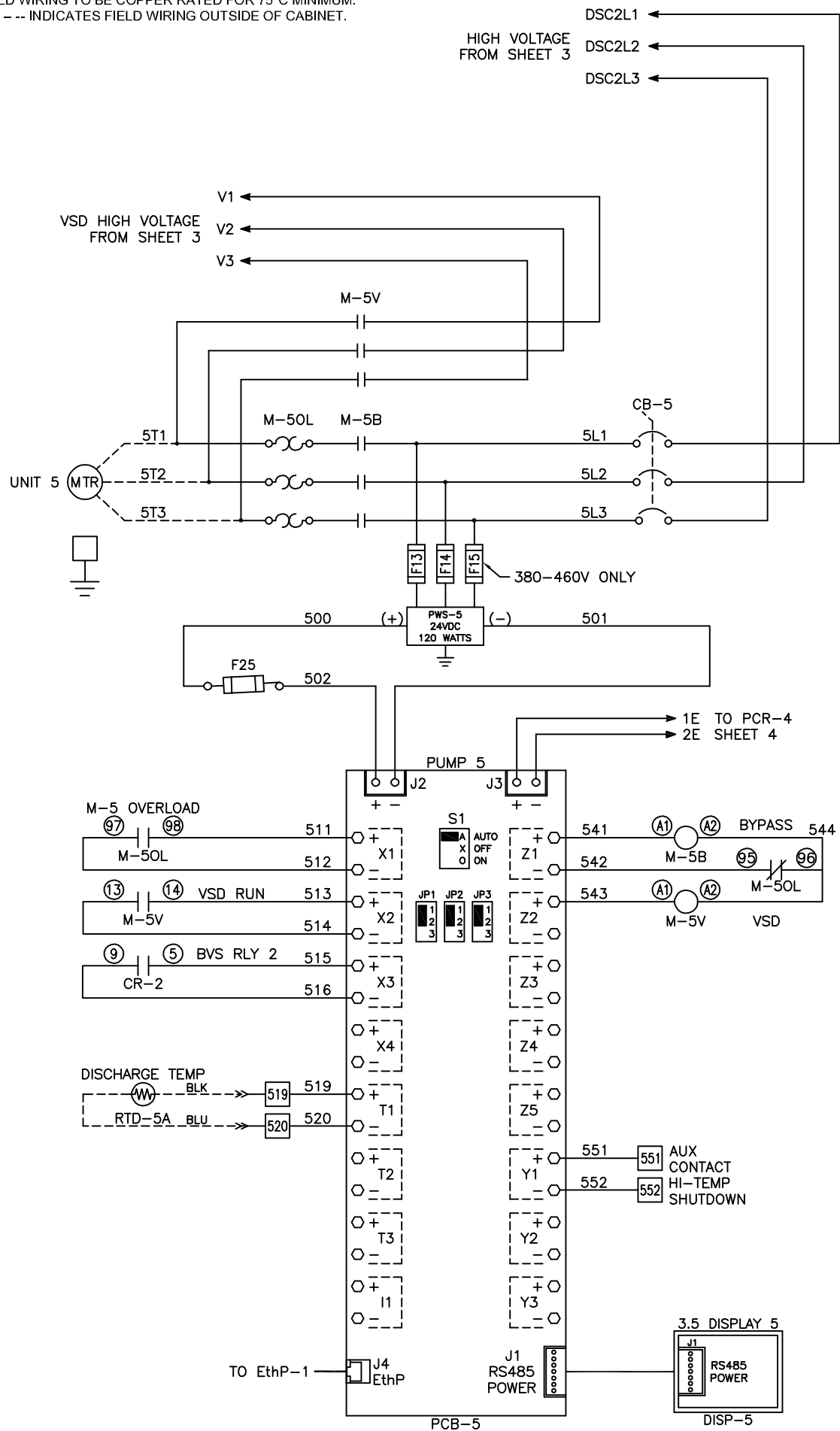

PUMP PCB
JUMPER/SWT SETTINGS

JPR/SWT	POSITION
JP1-JP3	1-2
S1	A (AUTO)

Revised:	Date:	Drawn:	MDB	Date:	10/30/18	
		<small>This drawing and the information contained therein are the property of Beacon Med. & S. and may not be used for other than the purpose for which it is issued without the express written permission from Beacon Med. & S. Engineering.</small>		Scale:	NTS	
Description: DWG WIRING CONTROL PX CLAW VSD 15HP 208-460/3/50-60, 65KA			Part Number: 4107 8568 51		Rev:	00
Drawn: HOP 180863			Sheet 4 of 5		DO NOT SCALE THIS DOCUMENT	

Notes:

1. FIELD WIRING TO BE COPPER RATED FOR 75°C MINIMUM.
2. - - - - - INDICATES FIELD WIRING OUTSIDE OF CABINET.

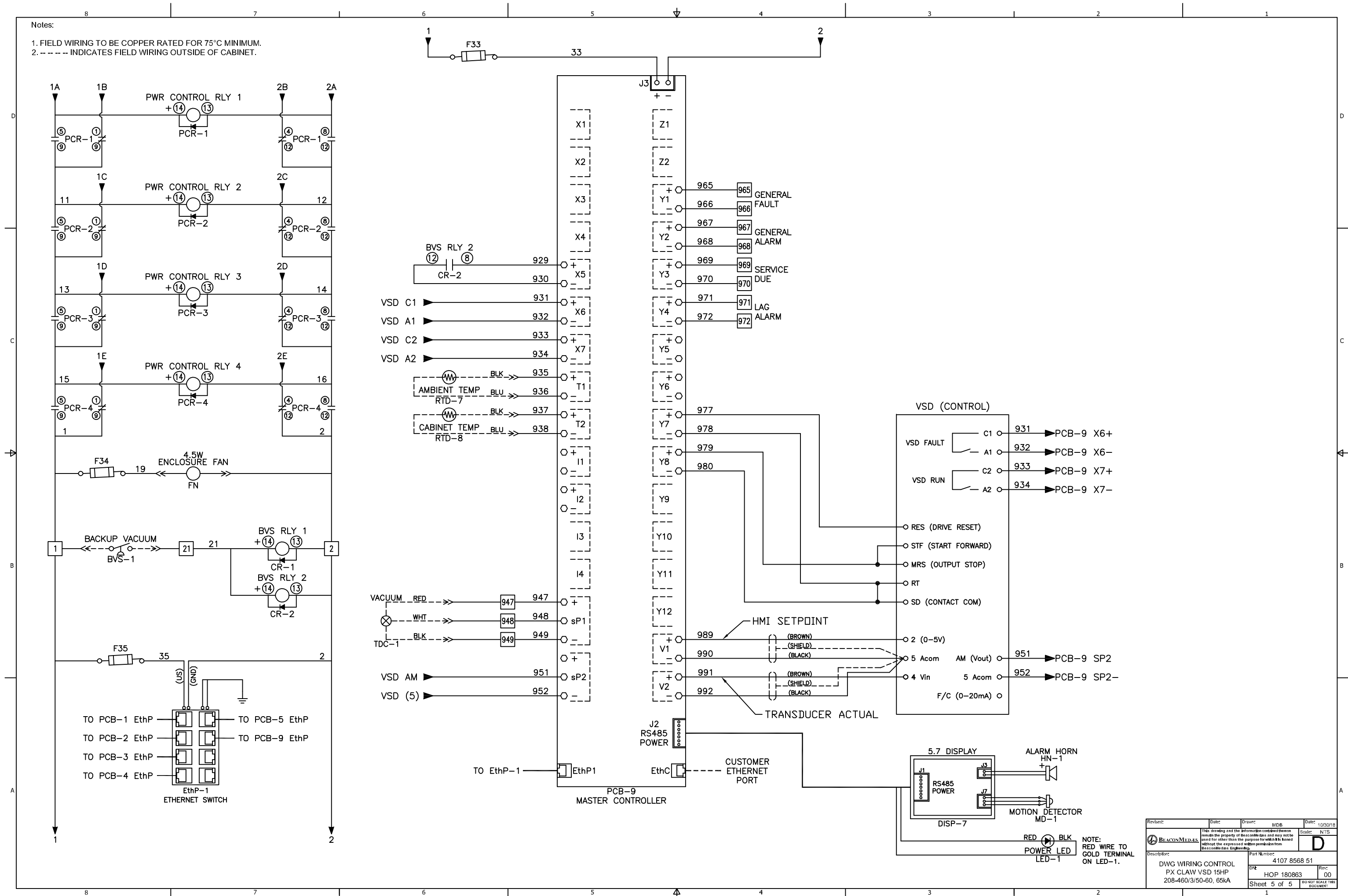

Revised:	Date:	Drawn:	MDB	Date:	10/30/18
				Scale:	NTS
This drawing and the information contained therein remain the property of Blacon Medical and may not be used for other than the purpose for which it is issued without the express and written permission from Blacon Medical Engineering.				D	Part Number: 4107 8568 51
DWG WIRING CONTROL PX CLAW VSD 15HP 208-460/3/50-60, 65KA					
Sheet 5 of 5				DO NOT SCALE THIS DOCUMENT	