

Notes:

1. THE AMPACITY OF CONDUCTORS SUPPLYING THE CONTROL PANEL TO BE ROUNDED UP TO THE NEXT SIZE LARGER STANDARD WIRE GAUGE.
2. MOP VALUES TO BE ROUNDED DOWN TO THE NEAREST STANDARD RATING OF THE OVERCURRENT PROTECTION DEVICE.
3. SHORT CIRCUIT CURRENT RATING (SCCR): 65 kA
4. POWER TO TERMINAL BLOCKS 3 & 4 OPENS ISOLATION VALVE 1
POWER TO TERMINAL BLOCKS 5 & 6 CLOSES ISOLATION VALVE 1
POWER TO TERMINAL BLOCKS 13 & 14 OPENS ISOLATION VALVE 2
POWER TO TERMINAL BLOCKS 15 & 16 CLOSES ISOLATION VALVE 2

AUTO OPERATION:

THE PUMP PCB WILL SIGNAL THE LEAD PUMP TO START AND THE ISOLATION VALVE TO OPEN WHEN THE VACUUM FALLS BELOW THE SET POINT. THE PUMP WILL CONTINUE TO RUN UNTIL THE VACUUM LEVEL SET POINT IS REACHED AND THE PUMP PCB WILL SIGNAL THE ISOLATION VALVE TO CLOSE AND THE PURGE VALVE TO OPEN. THE PUMP WILL THEN PURGE UNTIL THE PURGE TIMER EXPIRES. AFTER THE PURGE TIMER EXPIRES, THE PUMP PCB WILL SIGNAL THE PURGE VALVE TO CLOSE AND THE PUMP TO TURN OFF. IF THE VACUUM LEVEL FALLS BELOW THE SET POINT DURING THE PURGE CYCLE THE PCB WILL SIGNAL THE PURGE VALVE TO CLOSE, THE ISOLATION VALVE TO OPEN AND THE PUMP WILL RUN UNTIL THE VACUUM LEVEL SET POINT IS REACHED AND THEN BEGIN THE PURGE PROCESS AGAIN.

THE LEAD PUMP WILL ALTERNATE WHEN THE PUMP ALTERNATION TIME COMPLETES, FACTORY SET AT 10 HOURS. IF THE LEAD PUMP FAILS THE NEXT AVAILABLE PUMP WILL BECOME LEAD.

PUMP PCB S1 POSITION:

POSITION (A) – AUTO (DEFAULT):

THE PUMP WILL OPERATE NORMALLY AS DESCRIBED ABOVE IN "AUTO OPERATION".

POSITION (X) – OFF:

THE PUMP IS DISABLED FROM RUNNING.

POSITION (O) – MANUAL:

THE PUMP WILL RUN CONTINUOUSLY.

PCB FAULT:

IF A PUMP PCB ETHERNET FAULT OR A TRANSDUCER FAULT OCCURS, THE PUMP PCB WILL AUTOMATICALLY SWITCH TO EMERGENCY MANUAL MODE. VACUUM PUMPS WILL START WHEN BVS-1 (BACKUP VACUUM SWITCH) CLOSES AND STOP WHEN THE RUN TIMER EXPIRES.

AUXILIARY CONTACTS

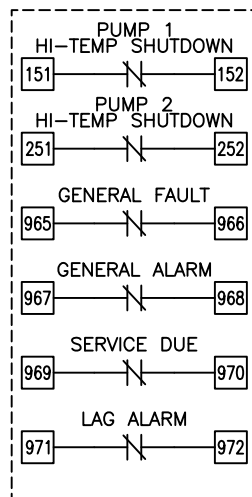

NOTE:
AUXILIARY CONTACTS 151-152, 251-252, & 965-972 ARE "CLASS 1 CONTROL CIRCUITS. USE CLASS 1 CONDUCTORS."

AUX CONTACTS ARE RATED 0.7A_{dc}/0.7A_{rms} @ 24V MAX. UNLESS OTHERWISE NOTED.

AUX CONTACTS CLOSED DURING NORMAL OPERATION.

MINIMUM CIRCUIT AMPACITY (MCA)

SYSTEM HP	208 V	230 V	380 V	460 V
2 HP	18.6 AMPS	16.9 AMPS	10.9 AMPS	8.7 AMPS
3 HP	25.6 AMPS	23.2 AMPS	15.0 AMPS	11.8 AMPS
4 & 5.4 HP	39.3 AMPS	35.8 AMPS	23.1 AMPS	18.1 AMPS
6.4 & 7.5 HP	56.2 AMPS	51.1 AMPS	32.8 AMPS	25.8 AMPS
8.7 & 10 HP	71.1 AMPS	64.6 AMPS	41.8 AMPS	32.5 AMPS
15 HP	105.7 AMPS	96.1 AMPS	62.0 AMPS	48.3 AMPS

MAXIMUM OVERCURRENT PROTECTION (MOP)

SYSTEM HP	208 V	230 V	380 V	460 V
2 HP	24.4 AMPS	22.1 AMPS	14.0 AMPS	11.1 AMPS
3 HP	34.5 AMPS	31.2 AMPS	19.8 AMPS	15.6 AMPS
4 & 5.4 HP	54.3 AMPS	49.4 AMPS	31.5 AMPS	24.7 AMPS
6.4 & 7.5 HP	78.7 AMPS	71.5 AMPS	45.5 AMPS	35.8 AMPS
8.7 & 10 HP	100.1 AMPS	91.0 AMPS	58.5 AMPS	45.5 AMPS
15 HP	150.2 AMPS	136.5 AMPS	87.8 AMPS	68.3 AMPS

INDIVIDUAL MOTOR NAMEPLATE FULL LOAD AMPERES

SYSTEM HP	208 V	230 V	460 V	S.F.	380V/50Hz	S.F.
2 HP	6.2 AMPS	5.6 AMPS	2.8 AMPS	1.25	2.6 AMPS	1.15
3 HP	9.4 AMPS	8.4 AMPS	4.2 AMPS	1.15	3.8 AMPS	1.15
4 HP	10.0 AMPS	9.2 AMPS	4.6 AMPS	1.25	5.0 AMPS	1.15
5.4 HP	12.4 AMPS	11.4 AMPS	5.7 AMPS	1.25	5.1 AMPS	1.15
6.4 HP	16.0 AMPS	15.8 AMPS	7.9 AMPS	1.25	8.6 AMPS	1.15
7.5 HP	22.0 AMPS	17.8 AMPS	8.9 AMPS	1.25	9.3 AMPS	1.15
8.7 HP	22.2 AMPS	21.2 AMPS	10.6 AMPS	1.25	11.3 AMPS	1.15
10 HP	27.2 AMPS	23.6 AMPS	11.8 AMPS	1.15	10.5 AMPS	1.15
15 HP	40.5 AMPS	35.0 AMPS	17.5 AMPS	1.15	14.5 AMPS	1.15

INDIVIDUAL OPERATING FULL LOAD AMPERES

SYSTEM HP	208 V	230 V	380V/50Hz	460 V
2 HP	6.6 AMPS	6.0 AMPS	2.8 AMPS	3.0 AMPS
3 HP	9.0 AMPS	8.0 AMPS	3.6 AMPS	4.0 AMPS
4 HP	9.3 AMPS	8.5 AMPS	4.6 AMPS	4.3 AMPS
5.4 HP	13.7 AMPS	12.6 AMPS	5.6 AMPS	6.3 AMPS
6.4 HP	17.4 AMPS	17.2 AMPS	9.4 AMPS	8.6 AMPS
7.5 HP	24.2 AMPS	19.6 AMPS	10.2 AMPS	9.8 AMPS
8.7 HP	25.1 AMPS	24.0 AMPS	12.8 AMPS	12.0 AMPS
10 HP	27.2 AMPS	23.6 AMPS	14.0 AMPS	11.8 AMPS
15 HP	40.5 AMPS	35.0 AMPS	14.5 AMPS	17.5 AMPS

DUPLEX SYSTEM FULL LOAD AMPERES

SYSTEM HP	208 V	230 V	380V/50Hz	460 V
2 HP	14.6 AMPS	13.3 AMPS	6.6 AMPS	6.8 AMPS
3 HP	20.2 AMPS	18.1 AMPS	8.6 AMPS	9.2 AMPS
4 HP	21.4 AMPS	19.7 AMPS	11.0 AMPS	10.0 AMPS
5.4 HP	28.8 AMPS	26.5 AMPS	12.2 AMPS	13.4 AMPS
6.4 HP	36.2 AMPS	35.7 AMPS	19.8 AMPS	18.0 AMPS
7.5 HP	49.8 AMPS	40.5 AMPS	21.4 AMPS	20.4 AMPS
8.7 HP	51.6 AMPS	49.3 AMPS	26.6 AMPS	24.8 AMPS
10 HP	55.8 AMPS	48.5 AMPS	29.0 AMPS	24.4 AMPS
15 HP	82.4 AMPS	71.3 AMPS	30.0 AMPS	35.8 AMPS

DEFAULT VACUUM SETTINGS ("HgV)

ALTITUDE	LEAD CUT-OFF		LAG CUT-ON		MAXIMUM LIMITS			MINIMUM LIMITS				
	15HP O2A	15HP O2A	15HP O2A	15HP O2A	15HP O2A	15HP O2A	15HP O2A	15HP O2A	15HP O2A	15HP O2A		
0-1000'	21	19	16	15	24	18	24	17	17	15	16	15
1001-2000'	20	18	16	15	23	18	23	17	17	15	16	15
2001-3000'	19	17	16	15	22	18	22	17	17	15	16	15
3001-4000'	18	17	16	15	21	18	21	17	17	15	16	15
>4000'	CONSULT FACTORY											

FUSE SELECTION CHART (MAX FUSE SIZES SHOWN)

SYSTEM HP	FUSES	208 V	230 V	380 V	460 V
2 HP	FL1/FL2/FL3	20 AMPS	17.5 AMPS	12 AMPS	12 AMPS
3 HP		30 AMPS	25 AMPS	12 AMPS	12 AMPS
4 HP		30 AMPS	25 AMPS	15 AMPS	15 AMPS
5.4 HP		---	---	17.5 AMPS	17.5 AMPS
6.4 HP		---	---	25 AMPS	25 AMPS
7.5 HP		---	---	30 AMPS	30 AMPS
8.7 HP		---	---	---	---
10 HP		---	---	---	---
15 HP		---	---	---	---
ALL		F1/F2/F4/F5	6.0 AMPS	6.0 AMPS	6.0 AMPS
	F3/F6	---	---	6.0 AMPS	6.0 AMPS
	F21/F22	4.0 AMPS	4.0 AMPS	4.0 AMPS	4.0 AMPS
	F33	1.0 AMPS	1.0 AMPS	1.0 AMPS	1.0 AMPS
	F35	0.5 AMPS	0.5 AMPS	0.5 AMPS	0.5 AMPS

FL1/FL2/FL3 ARE LITTELFUSE JTD 600V TYPE
F1-F6 ARE LITTELFUSE KLDR 600V TYPE
F21/F22/F33/F35 ARE LITTELFUSE 2AG 250V TYPE

OVERLOAD SETTINGS

SYSTEM HP	208 V	230 V	380V/50Hz	460 V
2 HP	7.3 AMPS	6.6 AMPS	3.1 AMPS	3.3 AMPS
3 HP	10.3 AMPS	9.2 AMPS	4.2 AMPS	4.6 AMPS
4 HP	11.0 AMPS	10.1 AMPS	5.5 AMPS	5.1 AMPS
5.4 HP	15.1 AMPS	13.9 AMPS	6.2 AMPS	6.9 AMPS
6.4 HP	19.1 AMPS	18.9 AMPS	10.3 AMPS	9.5 AMPS
7.5 HP	26.6 AMPS	21.6 AMPS	11.2 AMPS	10.8 AMPS
8.7 HP	27.6 AMPS	26.4 AMPS	14.1 AMPS	13.2 AMPS
10 HP	29.9 AMPS	26.0 AMPS	15.4 AMPS	13.0 AMPS
15 HP	44.6 AMPS	38.5 AMPS	16.0 AMPS	19.3 AMPS

RELIEF VALVE SETTINGS ("HgV)

ALTITUDE	O2 ASSURED PUMPS			
	2-5.4HP	6.4-8.7HP	10-15HP	15HP
0-1000'	N/A	24	23	N/A
1001-2000'	N/A	23	22	N/A
2001-3000'	N/A	22	21	N/A
3001-4000'	N/A	21	20	N/A
>4000'	CONSULT FACTORY			

BACKUP VACUUM SWITCH ("HgV)

BVS-1	CUT-ON	15	14

Revised: MDB	Date: 07/09/18	Drawn: MDB	Date: 10/30/18
		This drawing and the information contained therein remain the property of BeaconMedics and may not be used for other than the purpose for which it is loaned without the expressed written permission from BeaconMedics Engineering.	
Description: DWG WIRING CONTROL DX LAB CLAW 2-15HP 208-460/3/50-60, 65KA		Part Number: 4107 8568 53	
DN: HOP190789		Rev: 01	
Sheet 1 of 3		DO NOT SCALE THIS DOCUMENT	

Notes:

1. MAIN DISCONNECT PROVIDED BY OTHER.
2. FIELD WIRING TO BE COPPER RATED FOR 75°C MINIMUM.
3. - - - - - INDICATES FIELD WIRING OUTSIDE OF CABINET.

2-6.4HP 208-460V
 7.5HP 230-460V
 8.7 & 15HP 380-460V
 SCCR: 65 kA

7.5HP 208V
 8.7-15HP 208-230V
 SCCR: 65 kA

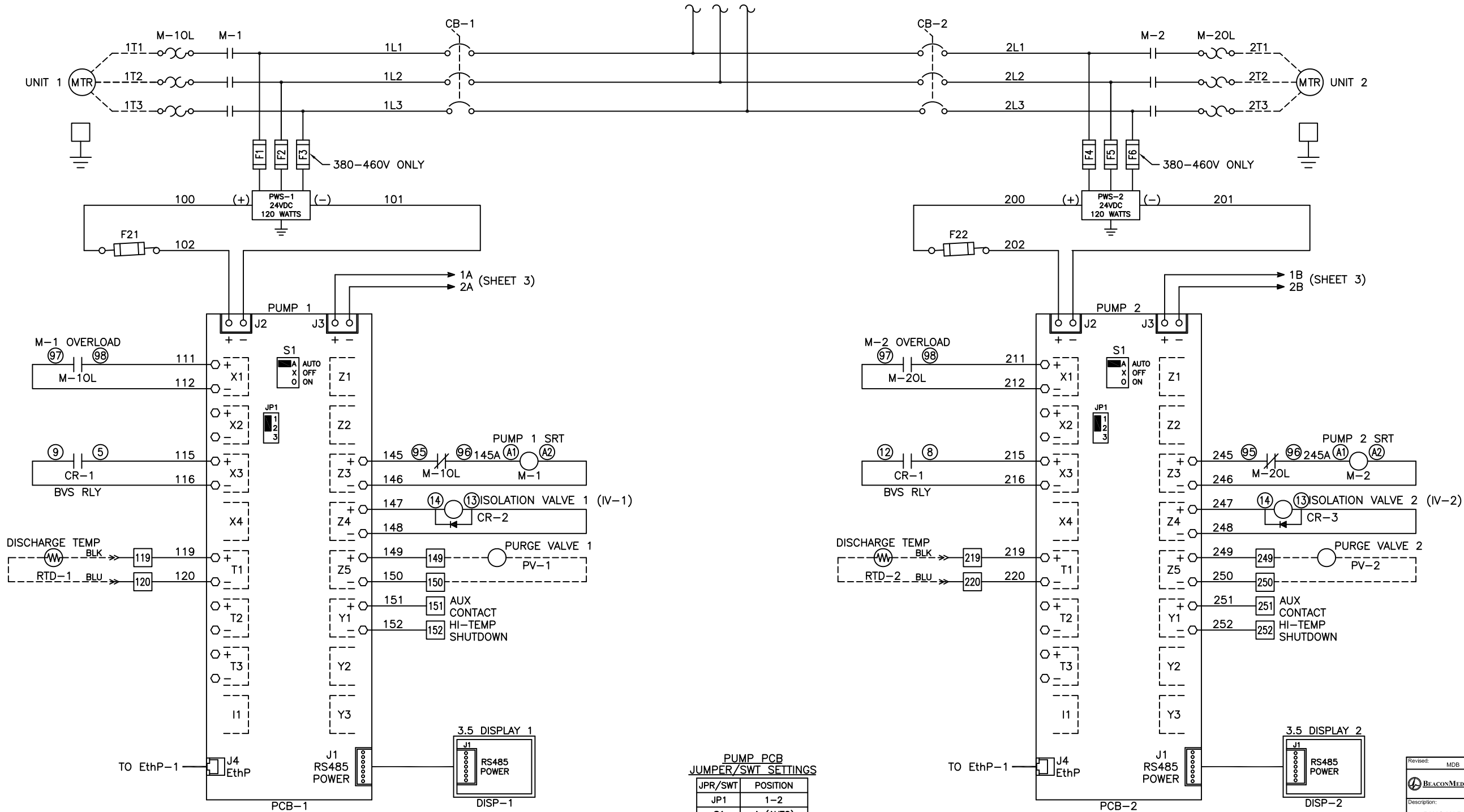
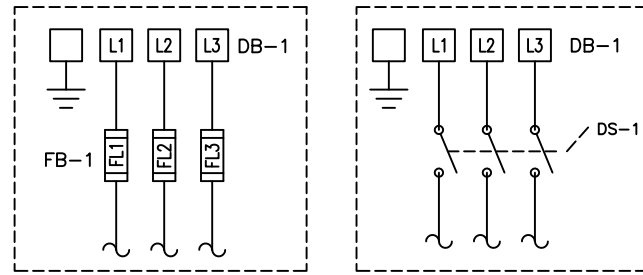

PUMP PCB
 JUMPER/SWT SETTINGS

JPR/SWT	POSITION
JP1	1-2
S1	A (AUTO)

Revised: MDB	Date: 07/09/19	Drawn: MDB	Date: 10/30/18
		This drawing and the information contained therein remain the property of BeaconMedes and may not be used for other than the purpose for which it is loaned without the expressed written permission from BeaconMedes Engineering.	
Description: DWG WIRING CONTROL DX LAB CLAW 2-15HP 208-460/3/50-60, 65kA		Part Number: 4107 8568 53	
DN: HOP190789		Rev: 01	
Sheet 2 of 3		DO NOT SCALE THIS DOCUMENT	

Notes:

1. FIELD WIRING TO BE COPPER RATED FOR 75°C MINIMUM.
2. - - - - - INDICATES FIELD WIRING OUTSIDE OF CABINET.

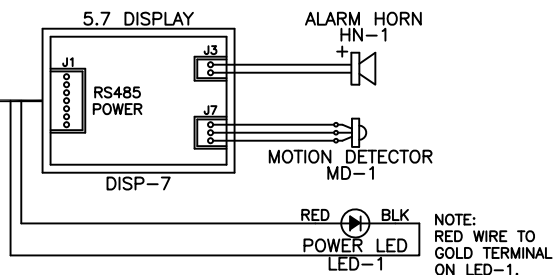
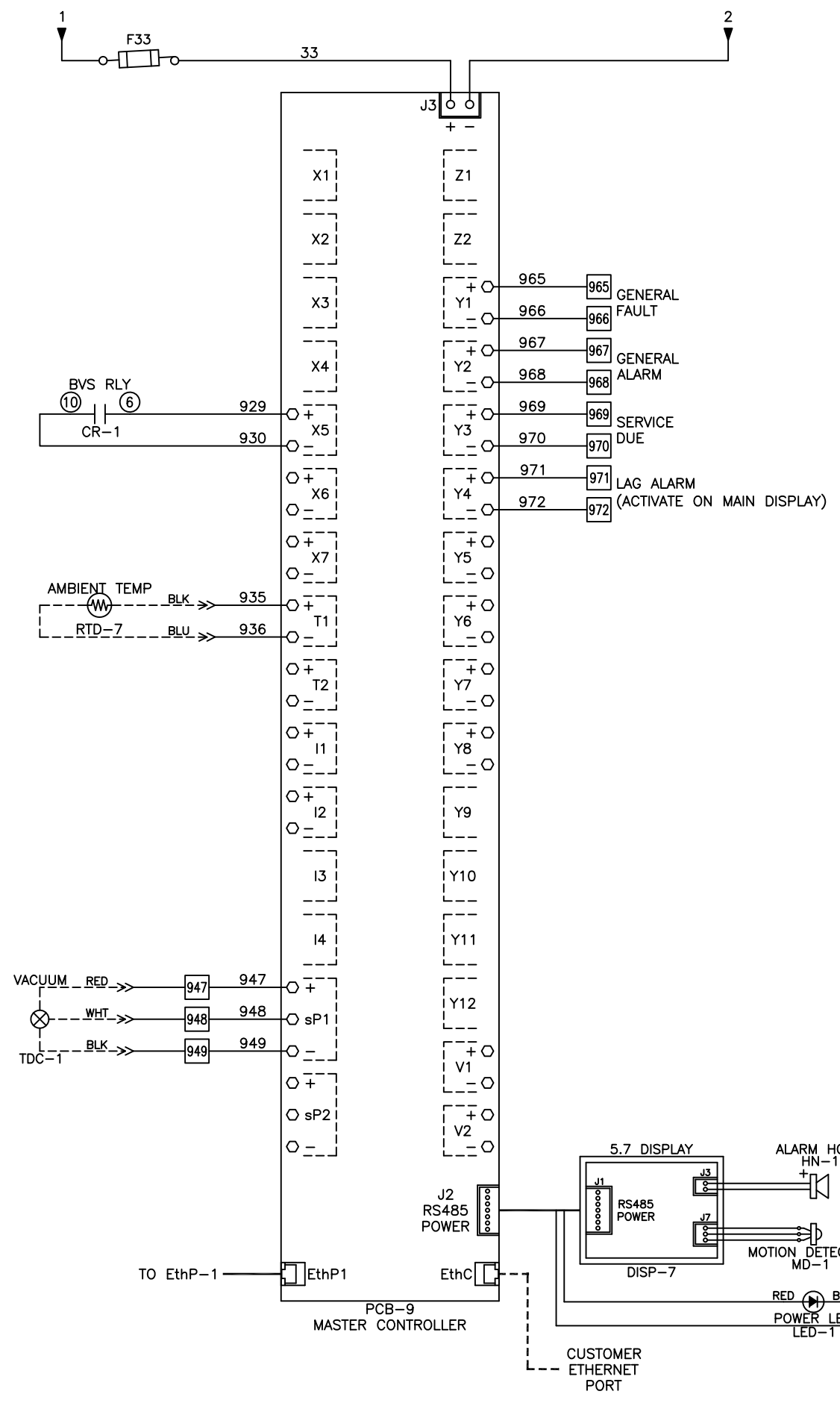
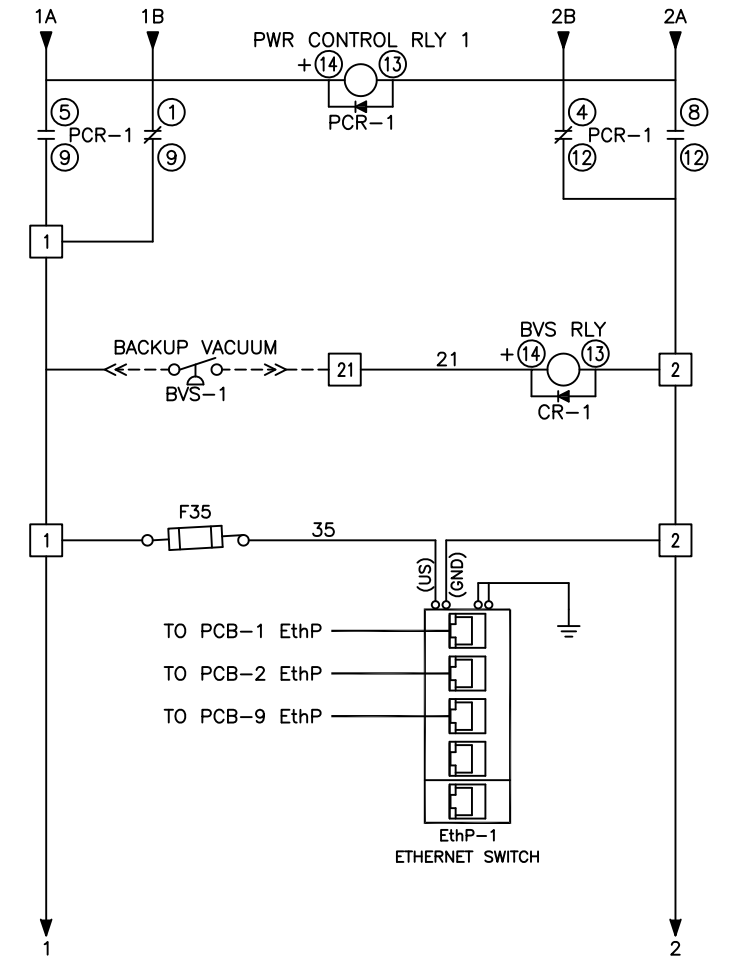
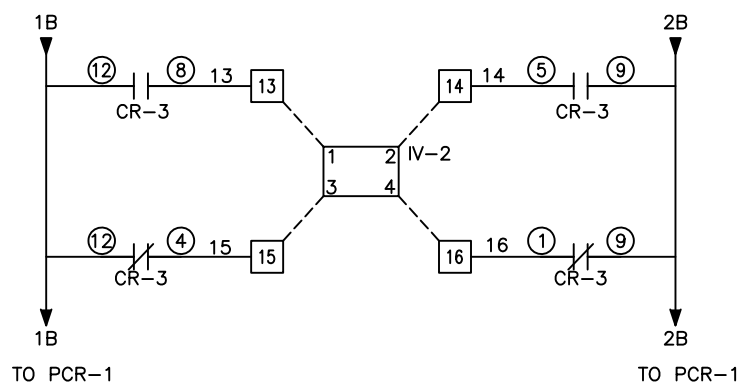
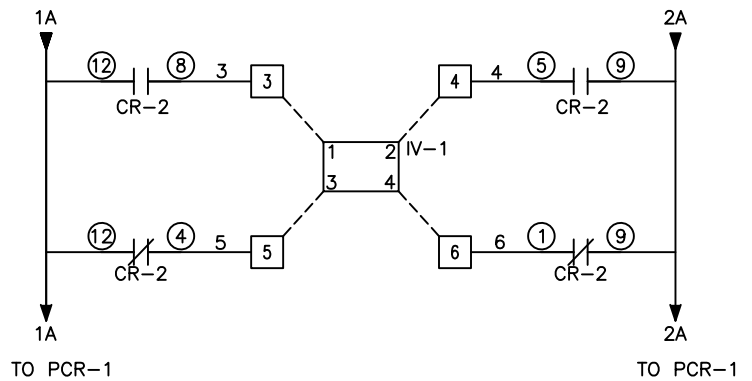

Revised: MDB	Date: 07/09/19	Drawn: MDB	Date: 10/30/18
		This drawing and the information contained therein remain the property of BeaconMedics and may not be used for other than the purpose for which it is loaned without the expressed written permission from BeaconMedics Engineering.	
Description: DWG WIRING CONTROL DX LAB CLAW 2-15HP 208-460/3/50-60, 65kA		Part Number: 4107 8568 53	
DN: HOP190789		Rev: 01	
Sheet 3 of 3		DO NOT SCALE THIS DOCUMENT	