

MODEL: LDD200D-DR WEIGHT: 446 lbs

INLET FLOW: 156 SCFM @ 75 PSIG
200 SCFM @ 100 PSIG
(INLET FLOW IS NFPA CAPACITY)

OPERATING CONDITIONS

- ELECTRICAL: 110VAC/1PH/50-60HZ 1.2A
230VAC/1PH/50-60HZ 0.6A
- MINIMUM WORKING PRESSURE: 60 PSIG
- MAXIMUM WORKING PRESSURE: 135 PSIG
- MAXIMUM INLET TEMPERATURE: 110° F
- ☒ INDICATES LIFTING POINTS
- DRYER TO BE INSTALLED DOWNSTREAM OF RECEIVER
- NOT RECOMMENDED FOR LIQUID RING APPLICATIONS

SYSTEM CONNECTIONS	
ID	DESCRIPTION
I	INLET LOCATION
D	DISCHARGE LOCATION

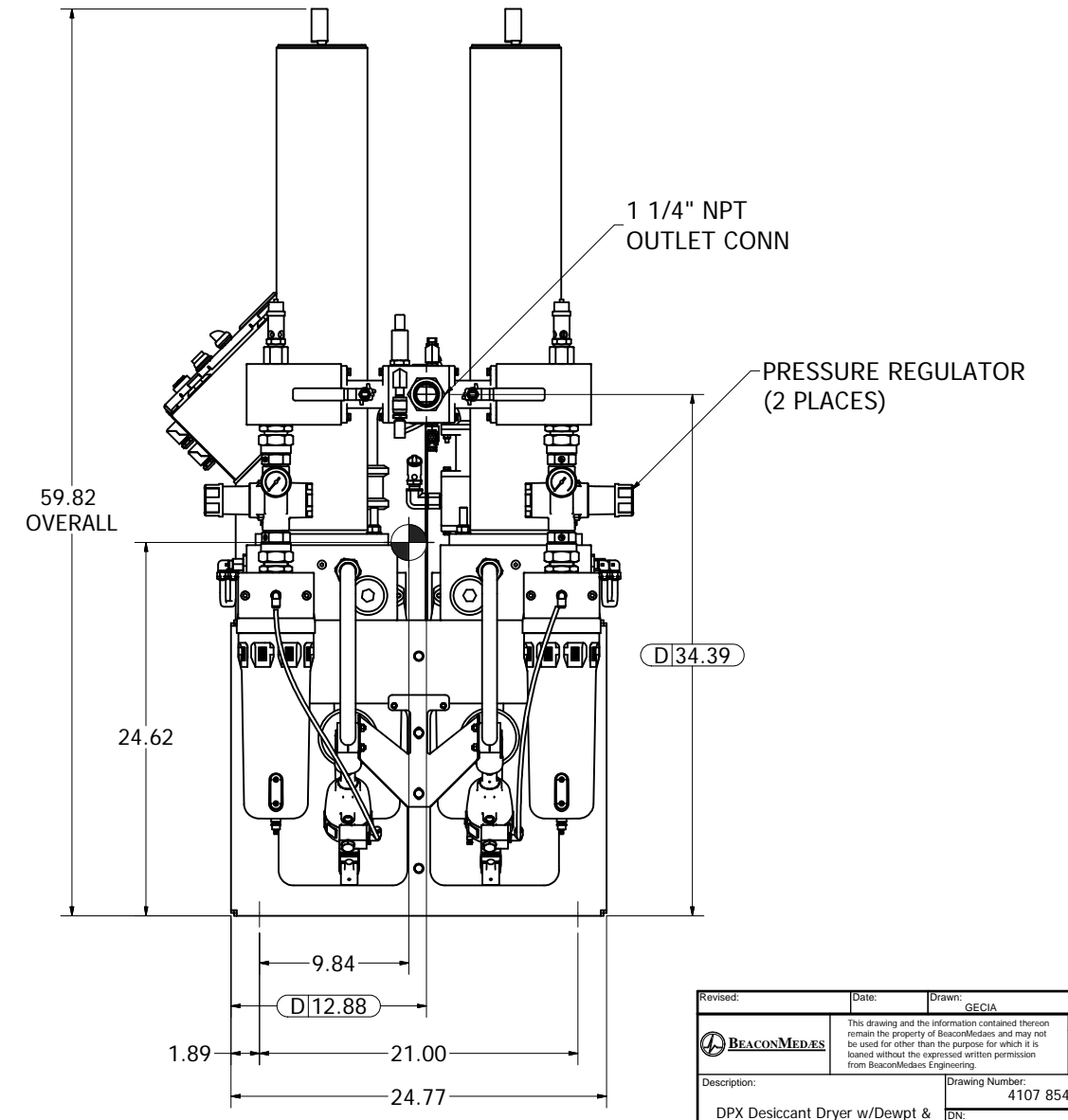
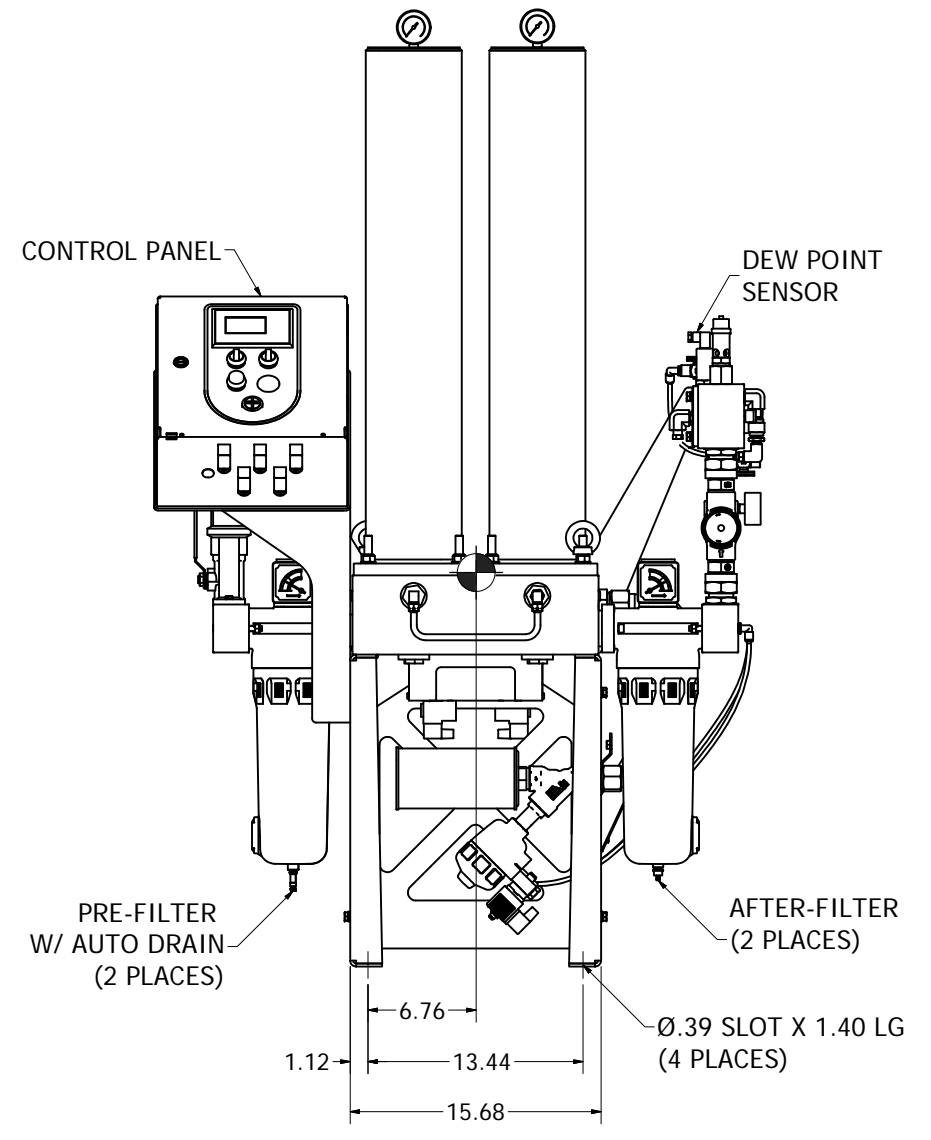
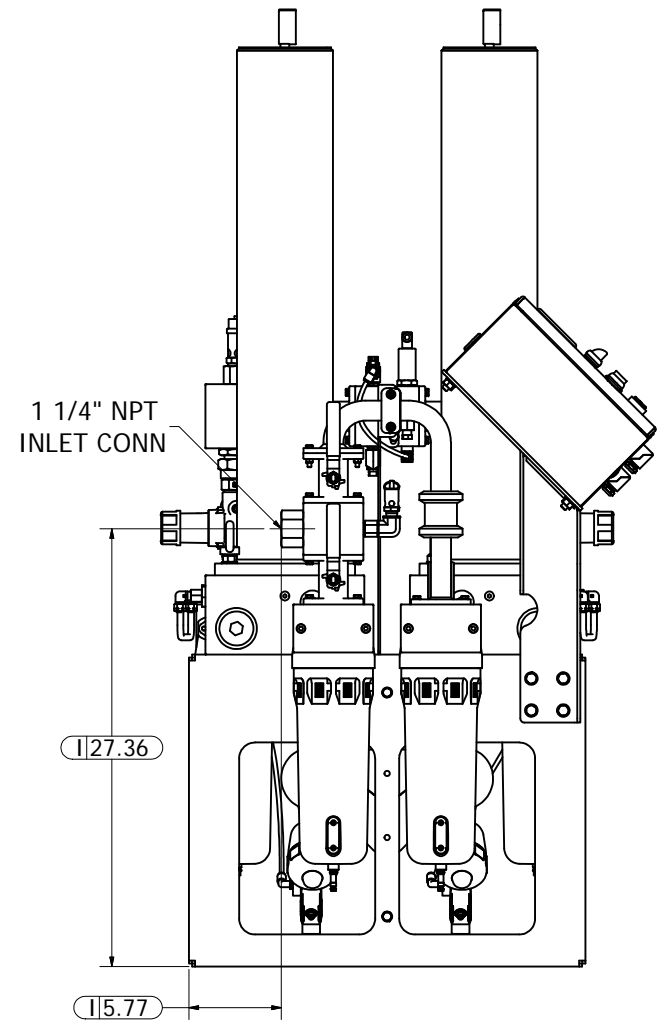
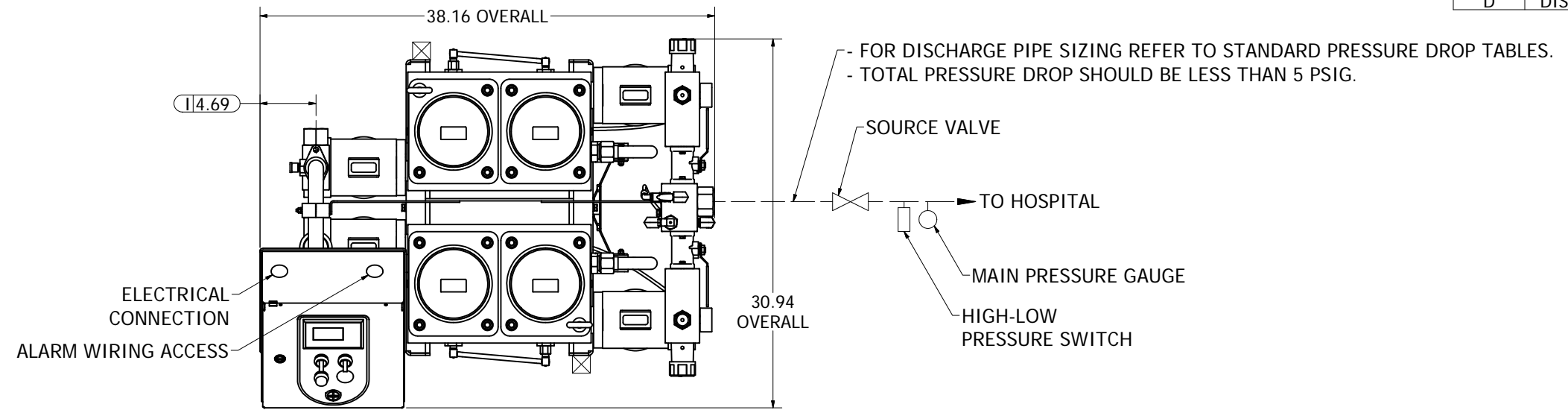

Revised:	Date:	Drawn: GE CIA	Date: 4/18/2013
		This drawing and the information contained therein remain the property of BeaconMedes and may not be used for other than the purpose for which it is loaned without the expressed written permission from BeaconMedes Engineering.	
Description: DPX Desiccant Dryer w/Dewpt & Reg, 200 CFM		Drawing Number: 4107 8540 50	Scale: 1:6 D
Sheet 1 of 1		Rev: 00 HOP120899	DO NOT SCALE THIS DOCUMENT