

## “Oil-Less” Scroll Laboratory Air Single Point Connection (SPC) Base Mount Duplex System (10-15 HP)

### SPECIFICATION

#### Single Point Connection (SPC) System Design

The Oil-Less Scroll Laboratory air package features a common base with single point connections for electrical, discharge air, and condensate drains. Designed and manufactured to ISO 13485 processes, each system is completely tested before shipment and includes:

- Two compressor towers, each with two “oil-less” scroll compressors and one motor
- Duplex desiccant drying system with purge control
- Integral pre-wired control panel
- Corrosion resistant vertical air receiver

#### Compressor Module

The compressors are continuous duty rated scroll type, single stage and air-cooled. The compressors have one fixed and one orbiting scroll sealed with PTFE tip seals.

- Field replaceable tip seals
- Dust and contamination protection from two part face seal
- Orbiting bearing and pin crank bearings are grease filled
- Heat dissipation maximized by an integral cooling fan
- V-belt driven compressor protected by totally enclosed beltguard
- Fully adjustable motor mounting base to achieve belt tensioning

#### Compressor Motor

The motor is NEMA rated, open dripproof and operates at 3600 RPM with 1.15 service factor suitable for 230/460V or 208V electrical service.

#### Compressor Assembly

Each compressor includes one inline inlet air filter. The compressor discharge assembly includes:

- Integral air-cooled aftercooler with a maximum approach temperature of 15°F above ambient and integrated drain trap with automatic solenoid drain valve
- Discharge lines include heat-shielded flex connector, safety relief valve, isolation valve and check valve
- Integral valve per compressor provides load-less starting and rapid air evacuation at shutdown

#### Isolation System

Four-point, heavy duty isolation system for a minimum 95% isolation efficiency fully isolates the compressor / motor tower from the system. Finite Element Analysis conducted to minimize vibration transfer. Seismically restrained isolators are available, providing OHSPPD pre-approved seismically restrained isolation.

#### Air Receiver

Corrosion resistant, ASME Coded, National Board Certified vertical air receiver rated for minimum 150 PSIG design pressure.

The air receiver assembly includes:

- Zero Loss electronic drain valve, liquid level gauge glass, safety relief valve, and manual drain valve
- Piped 3-valve bypass assembly with flange-fitted valves
- Pressure gauge

#### Dryer/Filter/Regulator System

Each desiccant dryer is sized for peak calculated demand and produces a 10° F (-12° C) pressure dew point. Each dryer operates from a demand based purge saving control system featuring repressurization cycles. The dryer assembly includes the following mounted and piped:

- 441™ transfer valve utilizing two sliding ceramic plates with a 5-year warranty
- High efficiency coalescing prefilter rated for 0.01 micron with automatic drain and element change indicator
- Fully duplexed final line particle filters rated for 1 micron with element change indicators
- Duplexed final line regulators and safety relief valves
- Ceramic type dew point sensor with ± 2° F system accuracy

#### TotalAlert Embedded Control System

The duplex mounted and wired TotalAlert Embedded control system is U.L. labeled. The control system provides automatic lead/lag sequencing and automatic alternation of both compressors based on first-on/first-off principle with provision for simultaneous operation if required.

- NEMA 12 control panel enclosure
- Circuit breaker disconnects for each motor with external operators
- Full voltage motor starters with overload protection
- 24V control circuit

The touch screen controls feature one 5.7” master screen and a 3.5” operating screen for each compressor. Screen displays and functions include:

- Service alerts, runtime hourmeters, system status, system pressure level, dew point level
- Visual/audible alarm indications with isolated contacts for all standard remote alarms
- Event log recording alarms and system activity
- Event log recording service warnings and service history
- Trend graphs for outlet pressure, Dew Point, and ambient temperature
- Ethernet connectivity and embedded web page for remote monitoring
- Electronic notifications of alarms and warnings
- Integral connectivity to the TotalAlert medical gas network via Ethernet

## Standard Configuration

Model Shown: 10 HP Duplex

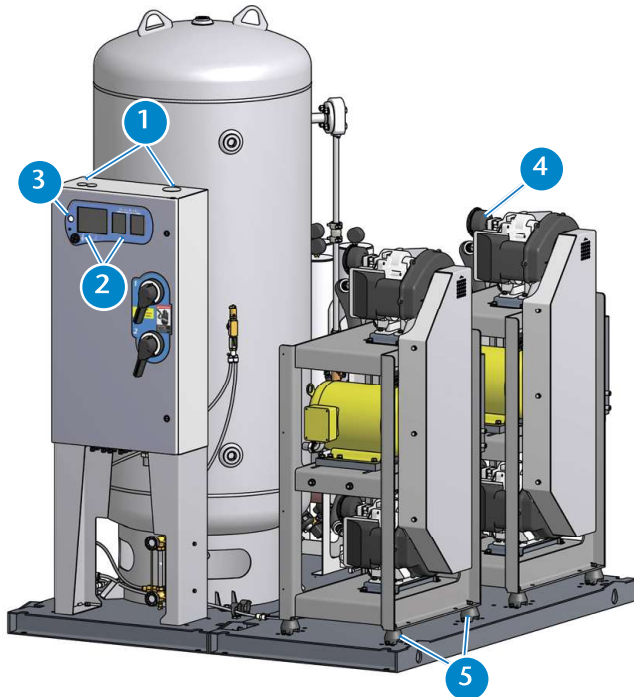

**1** Control panel pre-drilled for power, alarms, and Ethernet connections for easy electrical installation.

**2** TotalAlert Embedded touch screen controls featuring 5.7" master screen and (2) 3.5" operating screens with exceptional clarity and visibility.

**3** Motion sensor to activate touch screen displays, preserving screen life.

**4** Individual air inlet filter per compressor to protect compressors from incoming debris.

**5** 4-point heavy-duty isolation system for 95% isolation efficiency of compressor tower. Further vibration isolation achieved with flex hoses on intake and discharge.

**6** Aftercooler with separate cooling fan to provide maximum approach temperature of 15° F above ambient ensuring efficient dryer operation.

**7** Manifold dryer block design with SAE fittings to reduce potential leak points and to reduce pressure drop losses.

**8** 441® ceramic plate dryer switching valve with 150 million cycle anticipated life to reduce maintenance and downtime costs.

**9** Anodized aluminum blocks and flanged fittings utilized throughout air stream design to reduce leak points.

**10** Dryer towers with repressurization cycle to eliminate desiccant shock and minimize desiccant dusting.

**11** High efficiency inlet and outlet filters to protect the desiccant beds and laboratory air stream.

**12** Zero-Loss electronic discharge drain to save compressed air and remove moisture efficiently.

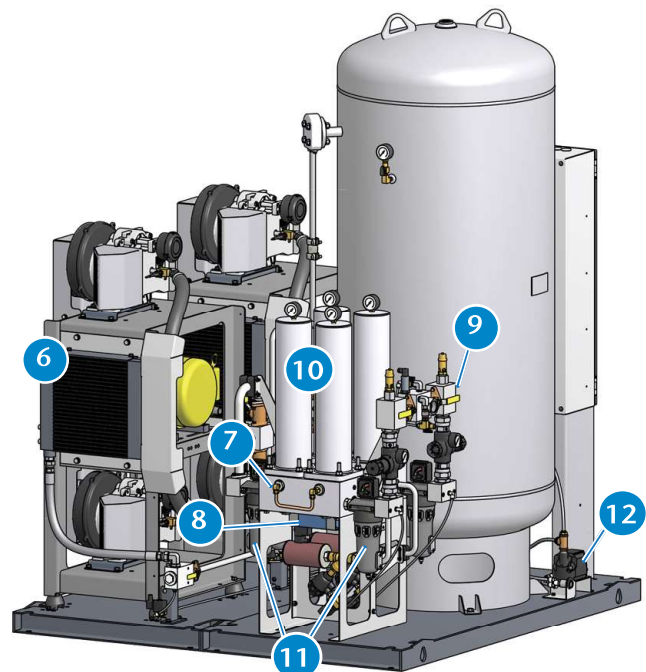

## TotalAlert Embedded Control System

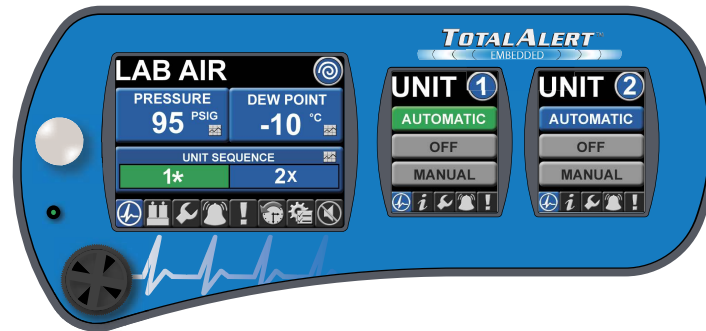

### Touch Screen Control

- Master screen is 5.7" high-resolution LCD with 640x480 pixel display and Unit screens are 3.5" high-resolution LCDs with 240x320 pixel display for exceptional clarity and visibility
- Toolbars on all screens with easy access navigation icons that enable full access with minimal touches
- PIR motion sensor activates screen display (under alarm conditions screen is active continuously)

### Ethernet Connectivity with Embedded Web Page

- Built-in web server allows remote operator to view system controls and display information
- Ethernet communication compatible with TotalAlert and TotalAlert<sup>2</sup> alarm systems
- Web page provided to show links to other devices on the TotalAlert Embedded network, including alarms and other source equipment
- Electronic notification
  - » Accessible through any SMTP gateway
  - » Allows for remote alerts of alarm and warning conditions
  - » Allows for remote alerts of routine maintenance
- All printed circuit boards have an Ethernet port that allows reprogramming with a standard computer for software updates
- Dual Ethernet configuration with separate Ethernet subnets to separate the facility Ethernet from internal TotalAlert Embedded communications

### Control Cabinet Safety

- Volt free relay contacts for all standard alarms
- Low voltage (24V) control circuit
- Full voltage motor starters with overload protection
- Circuit breaker disconnects for each compressor

### Redundancy

- In unlikely event of display boards or displays becoming disabled, unit will function normally and activate alarm
- If master board is disabled, system goes to failsafe operation with backup pressure switch
- Each compressor and dryer unit has independent board for control allowing unit to function independently

### Master Display Screen (5.7")

- Main Screen
  - » Displays the system operating conditions, including System Pressure, and Dew Point
  - » Displays the compressor unit sequence, including status of compressors (running, available, off) and next to start
- Trends & Graphs
  - » Shows measured values of the system operating conditions over a period of time (operating pressure, Dew Point, ambient temperature)
  - » Selectable time periods consist of 60 min, 4 hrs, 24 hrs, and 6 days
- Dryer Information
  - » Displays the operating mode of the dryer(s)
  - » Displays dryer image showing current status
- Service
  - » Displays ambient temperature in the room
  - » Maintenance screen shows suggested and required maintenance items with resettable timers
  - » Historical event log records all service activities
- Alarms and Shutdowns
  - » All system Alarms and Shutdowns displayed with visual indication (Green or Red)
  - » Testing mode enables operator to test all alarm events (password protected)
  - » Event History Log records all system event history
- System Settings
  - » Allows the adjustment of system pressure operating range (password protected)
  - » Displays pertinent system model information

### Unit Screens (3.5") - One per Compressor Unit

- Main Screen shows the operation mode of the unit along with the automatic or manual mode setting
- Unit status screen displays the running hour meter values
- Pump rotation allows the unit to run for a short period to check pump rotation
- All unit Alarms and Shutdowns displayed with visual indication (Green or Red)
- Audible indication for unit Shutdown Alarms
- Testing mode enables operator to test all shutdown events (password protected)

### Standard Configuration

10 Hp Dpx/200 gal shown

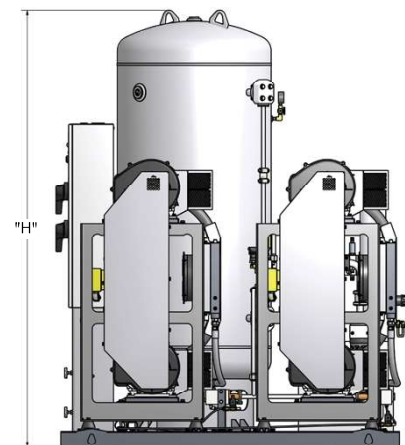
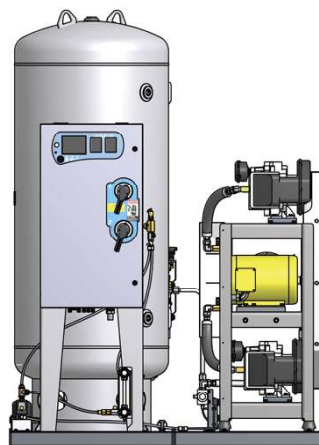
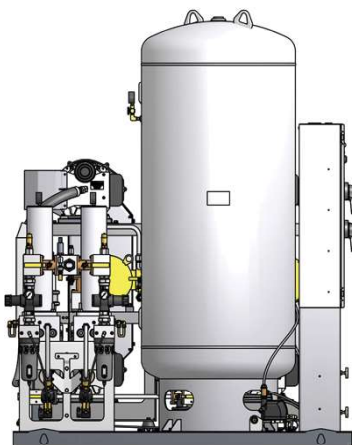
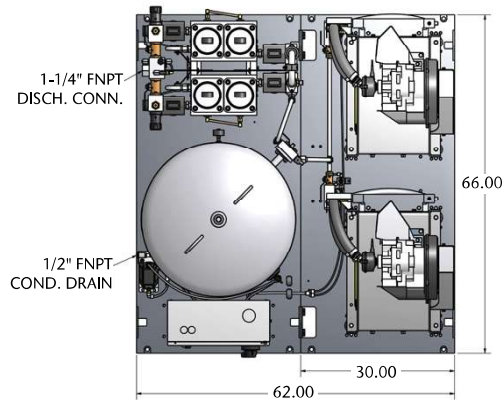

- Notes:**
- Discharge flex connections are built into package.
  - Allow 36 inches in front of control panel for maintenance and ventilation, all other sides require 24 inches of clearance.
  - Additional drawings/diagrams available for download at [www.beaconmedaes.com](http://www.beaconmedaes.com).

### Laboratory Air System Specifications<sup>1</sup>

System Model No.	HP	System Capacity <sup>2</sup> 145 psig	System <sup>3</sup> BTU/HR	Receiver (gallons)	Noise <sup>4</sup> Level	System FLA				System Weight (lbs.)	Dimensions (in.)
						208V	230V	460V	380V 50 Hz		H
LAS10D-200V-D	10	47.3	23,014	200	76	52.2	49.3	24.8	27.8	2,186	85.1"
LAS10D-240V-D	10	47.3	23,014	240	76	52.2	49.3	24.8	27.8	2,288	97.1"
LAS15D-200V-D	15	68.0	68,715	200	77	78.8	71.3	35.8	42.0	2,400	85.1"
LAS15D-240V-D	15	68.0	68,715	240	77	78.8	71.3	35.8	42.0	2,502	97.1"

- Notes:**
1. Normal operating conditions at a maximum ambient of 105° F. Consult factory for higher ambient conditions.
  2. All capacities are shown as system capacities (all compressor modules running) and are shown in Standard Cubic Feet per Minute (SCFM). Unit performance measured according to ISO 1217, Ed. 3, Annex C-1996. Reference conditions: absolute inlet pressure 14.5 psig, intake air temperature 68° F. System capacity does not account for losses due to dryer purge or other system losses.
  3. All system BTU/HR are shown with all compressor modules running.
  4. All noise levels are shown in dB(A) and all compressor modules running.
  5. **System is designed for output pressure of 100 psig (690 kPa). For alternate pressures contact factory.**