

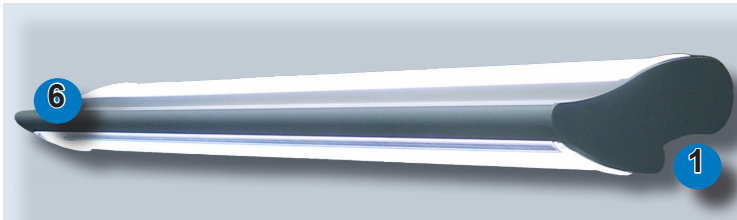

Hospital Luminaires



Key Features

1. Superior aesthetics
2. Pre wired to 20A multi-pole connectors
3. Extruded aluminium body
4. High grade powder coat finish
5. TL5 lamps and high frequency ballasts
6. Single lamp up and downlights
7. Dimmable downlight using SwitchDIM technology
8. Removable full length diffusers
9. Easy to clean IP50 surface with minimal wall interface contact
10. Lighting photometrics providing low glare output

Benefits

- Curvaceous flowing design compliments any decor
- Quick and easy to install
- Durable and robust construction
- Supported by a 25 year Applicators Guarantee
- For long life and maximum efficiency
- Reduced power consumption
- Meets CIBSE LG2:2008 (1-100%) with dimmable or fixed output
- Enhanced light output
- To help minimise cross infection risk and virtually eliminate dust traps
- Proven lighting technology for optimum performance

Life
is in the
details.



A Superior Mounting Solution

The BeaconMedaes luminaire is designed and manufactured in accordance with BS EN60598-1 & -2-25, BS EN 60601-1, BS EN 12464-1 and CIBSE LG2:2008, specifically for installation within a medical environment. The luminaire provides general lighting as well as patient reading, observation and minor examination light.

The compact 880mm length luminaire (39/21w) is mounted directly to the wall by a slim interface bracket in order to achieve minimal wall contact, providing unhindered access from all sides of the unit.

The smooth curves and styling of the luminaire enhance the appearance of any patient area and provide a surface that is easy to clean in order to help minimise the risk of cross infection.

Luminaires are fully pre-wired to 20A multi-pole connectors ready for simple connection to the electrical supply. The unit is supplied as a 2nd fix luminaire unit and a 1st fix interface bracket enabling the wiring and mechanical fixing to be completed at an early stage on site.

Other benefits include:-

- High quality, durable construction with a high grade powder coat finish supported by a 25 year Applicators Guarantee
- Optional LED night light

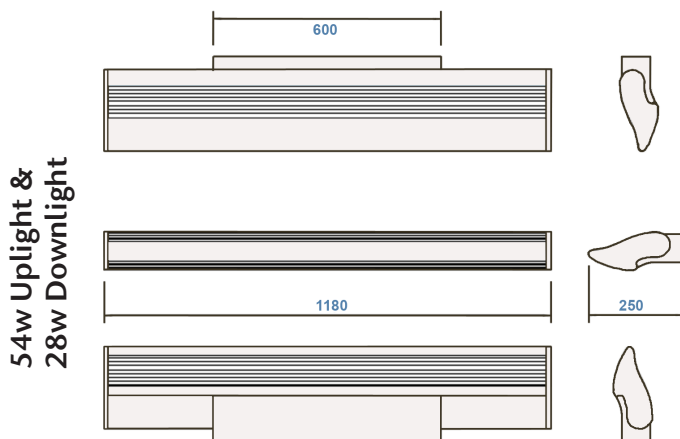

Optimised Lighting Output

The BeaconMedaes hospital luminaire includes proven lighting technology and photometrics. High frequency quick start ballasts and TL5 lamps are incorporated to provide efficient and flicker free operation. This enables energy consumption to be reduced by up to 60% over conventional lighting units.

Replaceable diffusers optimise the length of the luminaire in order to maximise light output.

Uplights and downlights are individually controlled and can be switched by the patient nursecall system by connecting the incoming low voltage relay control cable to the multi-way connector.

The 21w or 28w output downlight makes the luminaire suitable for numerous applications such as reading, observation and minor examination as defined in CIBSE LG2 standards.

Careful consideration was given to glare and viewed luminance levels when designing the diffuser to ensure patient comfort, which meets the LG2 glare recommendations.

The BeaconMedaes hospital luminaire is extensively electrically and EMC tested for use within the medical environment and is certified to EN 60601-1, and meets the essential requirements of the Medical Devices Directive 93/42/EEC.

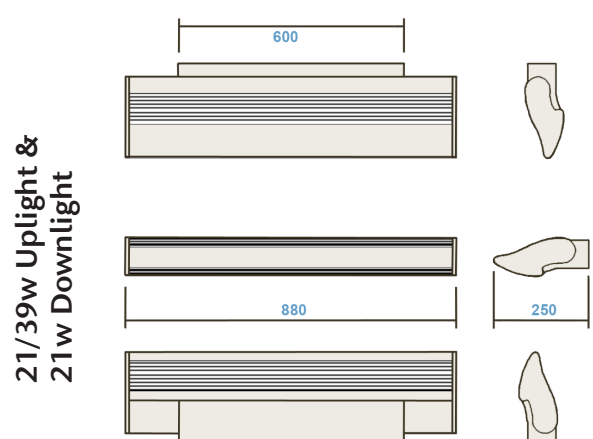

- * Fluorescent tubes are also supplied but no risk is taken for any damage occurred during transit.
- ** Relays for nursecall control are provided by others as a component part of the nursecall system.

BeaconMedaes

Part of the Atlas Copco Group
Telford Crescent, Staveley,
Derbyshire, S43 3PF, England
Tel: +44 (0) 1246 474 242
www.beaconmedaes.com

