

## LifeLine<sup>®</sup> "Oil-Free" Rotary Tooth Medical Air Triplex Modular System (40 - 60 HP)

T

### SPECIFICATION

#### Modular System Design

The medical air system shall be of a modular base mounted design consisting of three compressor modules, a dryer/control module, and an air receiver module. Each module must be fully compliant with the latest edition of NFPA 99.

#### Compressor Module

The compressor modules are fully enclosed with sound attenuated steel panels with full access doors for maintenance and inspection. Each compressor module includes the compressor, drive motor with starter, oil system, and a compressor control system. The compressor intake is equipped with an air intake filter and integral shutoff/unloading valve. Unloading is carried out by closing the intake valve. Loading or unloading of the unit is controlled by a pressure transducer which will actuate the loading solenoid valve. The air discharge for the compressor module has a pulsation damper, check valve and manual isolation valve. Ventilation for the module is supplied by a radial fan with a separate motor. The control system will display the runtime hours, temperature readouts, pressure readouts, service indicators, safety warnings and safety shutdowns for the compressor module.

#### Compressor

The compressor is a two-stage, oil-free compressor block, consisting of separate low and high pressure rotary tooth compressor elements flanged to a common step-up gearbox. The compressor elements are air cooled. The high and low compressor elements are supplied with safety relief valves. The first stage air is cooled by an intercooler with moisture trap and automatic drain valve. The second stage air is cooled by an aftercooler with moisture trap with manual and automatic drain valve. The gearbox oil system includes an oil sump, pump, oil filter, bypass valve, drain connection, sightglass and cooler.

#### Compressor Drive

The compressor shall be direct driven. Torque is transmitted from the motor to the compressor through a flexible shaft coupling.

#### Compressor Motor

The motor shall be a flange-mounted high efficiency motor, 3600 RPM, with 1.15 service factor suitable for 230 or 460 volt, 60 hertz, 3 phase electrical service. The motor is equipped with a Y-Delta starter, mounted and wired, to reduce current spikes when the motor is started.

#### Isolation System

The compressor and motor shall be fully isolated from the main compressor module base by means of a heavy-duty isolation system for a minimum of 95% isolation efficiency.

#### Dryer/Control Module

The dryer/control module shall include a central control system to control multiple compressors and a duplexed desiccant drying system with dew point hygrometer/ CO transmitters. Each dryer includes inlet filters, final line filters and regulator. All of the above shall be factory piped and wired in accordance with NFPA 99 and include valving to allow complete air receiver bypass, and air sampling port.

#### Dryer/Filter/Regulator System

Each desiccant dryer must be individually sized for peak calculated demand and capable of producing a -40°F (-40°C) pressure dew point. Dryer purge flow shall be minimized through an integral demand based purge saving control system. The inlet to each dryer shall include a 1 micron coalescing filter and a .01 micron high efficiency coalescing filter with automatic drains. The duplexed final line filters consist of a 1 micron particulate filter and one active carbon filter, duplexed final line regulators, single oil indicator and duplexed safety relief valves shall be factory mounted and piped. All filters shall have element change indicators. Final line regulators set for system delivery pressure of 55 psig.

#### Central Control System

The mounted and wired central control system shall be NEMA 12, U.L. labeled and rated for 115V single phase electrical service. The control system shall provide automatic lead/lag sequencing, visual and audible reserve unit alarm with isolated contacts for remote alarm. Automatic alternation of all compressors based on a first-on/first-off principle with provisions for simultaneous operation if required, automatic activation of reserve unit if required, visual and audible alarm indication for high discharge air temperature shutdown with isolated contacts for remote alarm shall be included.

#### Dew Point/CO Transmitters

The dryer/control module shall incorporate a dew point and CO transmitter that is mounted, pre-piped, and wired. Dew point and CO conditions will be displayed on the central control system. The dewpoint transmitter probe shall be the ceramic type sensor. The system accuracy shall be a minimum of  $\pm 2^{\circ}$  C for dew point and  $\pm 2$  PPM (at 10 PPM) for carbon monoxide. Dew point alarm shall be factory set at 36° F (2° C) per NFPA 99, and the CO alarm shall be factory set at 10 PPM. Both set points shall be field adjustable. High CO and high dew point conditions shall be indicated with visual and audible alarms.

#### Air Receiver Module

The vertical air receiver shall be ASME Coded, National Board Certified, corrosion resistant, rated for a minimum 150 PSIG design pressure and include a liquid level sight glass, pressure gauge, safety relief valve, manual drain valve and automatic solenoid drain valve.

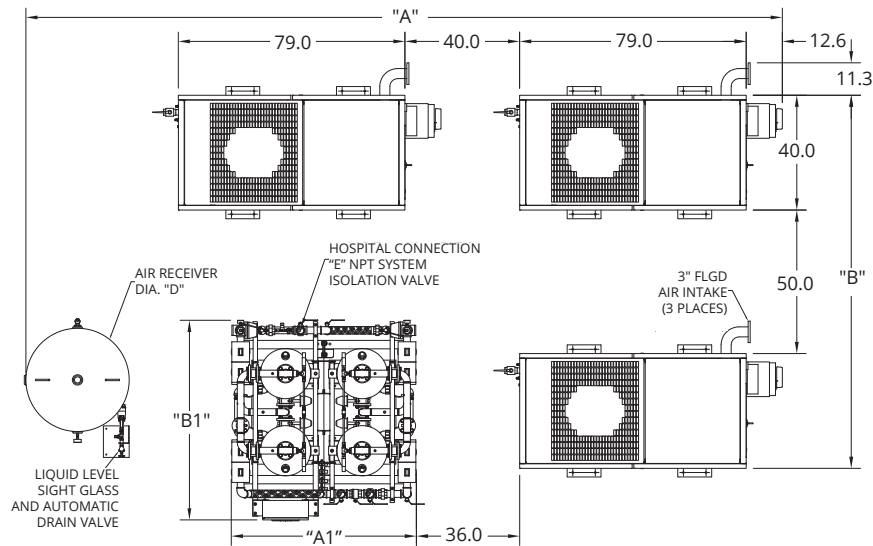
**Notes:**

- This is a modular system, bring high voltage power to each compressor (3 places) and 120V power to the central control panel.
- Flexible intake and discharge connections ship loose.
- No special foundation or inertia pad is required (housekeeping pad is optional). No vibration pads are necessary.
- Additional drawings/diagrams available for download at [www.beaconmedaes.com](http://www.beaconmedaes.com).
- Consult manuals shipped with each system for pertinent installation details.

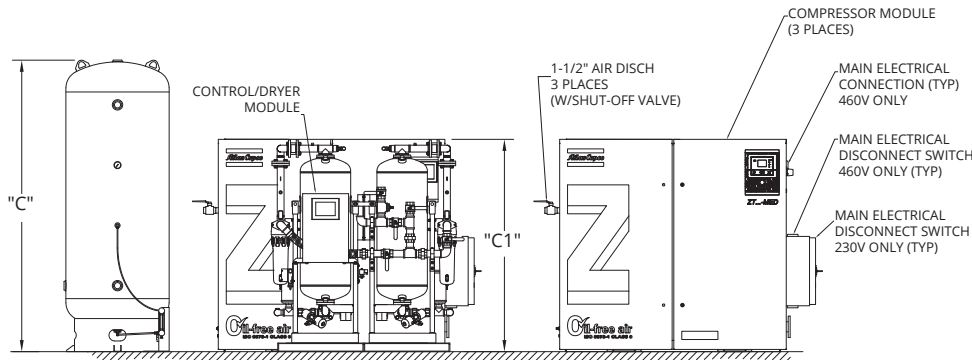

Model Number	Unit (HP)	Receiver (gallons)	Dimensions (in)								SQ Feet Required
			A*	A1	B*	B1	C	C1	D	E	
ZTM-30T-D400-T	40	400	253	58.4	130	57.7	102	73.8	36	1-1/2	232
ZTM-37T-D400-T	50	400	253	58.4	130	57.7	102	73.8	36	1-1/2	232
ZTM-45T-D400-T	60	400	264	64.3	130	65.2	102	76.8	36	2	235

\*Suggested System Dimensions

Medical Air System Specifications <sup>1</sup>													
System Model No.	HP	Pump Model	Capacity FAD <sup>2</sup> (CFM)	System <sup>3</sup> BTU/HR	Receiver (gallons)	Noise <sup>4</sup> Level	System FLA		Compressor FLA (each)		System Weight (lbs.)		
							460	230	460	230	Module <sup>5</sup>	Dryer	Receiver
ZTM-30T-D400-T	40	ZT30	334	183,200	400	66	196.3	388.3	65	129	2648	2362	732
ZTM-37T-D400-T	50	ZT37	408	229,000	400	68	232.3	457.3	77	152	2758	2362	732
ZTM-45T-D400-T	60	ZT45	486	274,800	400	70	283.3	562.3	94	187	2842	3080	732

**Notes:**

1. Normal operating conditions at a maximum ambient of 105° F. Consult factory for higher ambient conditions.
2. All capacities are shown as NFPA system capacities (reserve compressor on standby). Reference conditions: absolute inlet pressure 1 bar (14.5 psi); intake air temperature 20°C (68°F); 7.5 bar (109 psi) max. working pressure. NOTE: System delivery pressure is 55 psig. For higher delivered pressure, contact factory.
3. All system BTU/HR are shown with reserve compressor on standby.
4. All noise levels are shown in dB(A) and reflect reserve compressor on standby.
5. Module weight represents one compressor module.