

**LifeLine® “Oil-Less” Claw Medical Vacuum  
Base Mount Modular  
Pentaplex Expandable to Hexaplex (15 HP) 50 Hz**

**SPECIFICATION**

**Modular System Design**

The LifeLine® Oil-Less Claw Medical vacuum package is fully compliant with NFPA 99. Each pump module has a common intake connection point. Each module can fit through a standard 34.5" doorway. Designed and manufactured with ISO 13485 processes, each system is completely tested before shipment and includes:

- Five "oil-less" claw rotary vacuum pumps with five motors
- Integral pre-wired control panel
- Vertical air receiver sized for appropriate demand
- Piping provisions included for future expansion module

**Vacuum Pump**

Each pump is a direct driven, non-contacting claw type, capable of operating continuous duty at 24" Hg (sea level).

The pumping chamber is oil free. The pump is completely air-cooled with no water requirements. Each pump contains:

- 5 micron inlet air filter
- Vacuum relief valve
- Check valve to prevent backflow through off-cycle units
- Flexible connector and isolation valve
- High discharge temperature sensor
- Oil drain valve and oil sight glass
- Exhaust muffler

**Vacuum Pump Motor**

Motors are continuous duty, NEMA rated, C-face, TEFC, 2875 RPM, suitable for 380V, 50 hertz, 3-phase electrical service.

**Intake Piping**

Each vacuum pump has a factory piped intake with integral flex connector, isolation valve, and check valve. Interconnecting piping consists of powder-coated steel tubing and flanges.

**Vacuum Receiver**

The vacuum receiver is ASME Code stamped, and rated for a minimum 150 PSIG design pressure.

The receiver has a full-size three-valve bypass system to allow for draining of the receiver without interrupting the vacuum service. A manual drain is provided on the receiver.

**TotalAlert Embedded Control System**

The hexaplex mounted and wired TotalAlert Embedded control system is U.L. labeled. The control system provides automatic lead/lag sequencing and automatic alternation of vacuum pumps based on first-on/first-off principle with provision for simultaneous operation if required. Automatic activation of reserve unit, if required, will activate an audible alarm as well as a visual alarm on the display screen.

Additional components include:

- NEMA 12 control panel enclosure
- Circuit breaker disconnects for each motor with external operators
- Full voltage motor starters with overload protection
- 24V control circuit

The touch screen controls feature one 5.7" master screen and a 3.5" operating screen for each vacuum pump. Screen displays and functions include:

- Service alerts, runtime hourmeters for each pump, system status, system vacuum level
- Visual/audible alarm indications with isolated contacts for all standard remote alarms
- Event log recording alarms and system activity
- Event log recording service warnings and service history
- Trend graphs for vacuum level, pump operations, and ambient temperature
- Ethernet connectivity and embedded web page for remote monitoring
- Electronic notifications of alarms and warnings
- Integral connectivity to the TotalAlert medical gas network via Ethernet

**Installation**

The installation of this vacuum technology is limited to the maximum of 4,000 feet elevation level above sea level.

For installation of this equipment above this elevation, please contact the factory.



## Standard Configuration

15 HP Pentaplex  
Expandable to Hexaplex

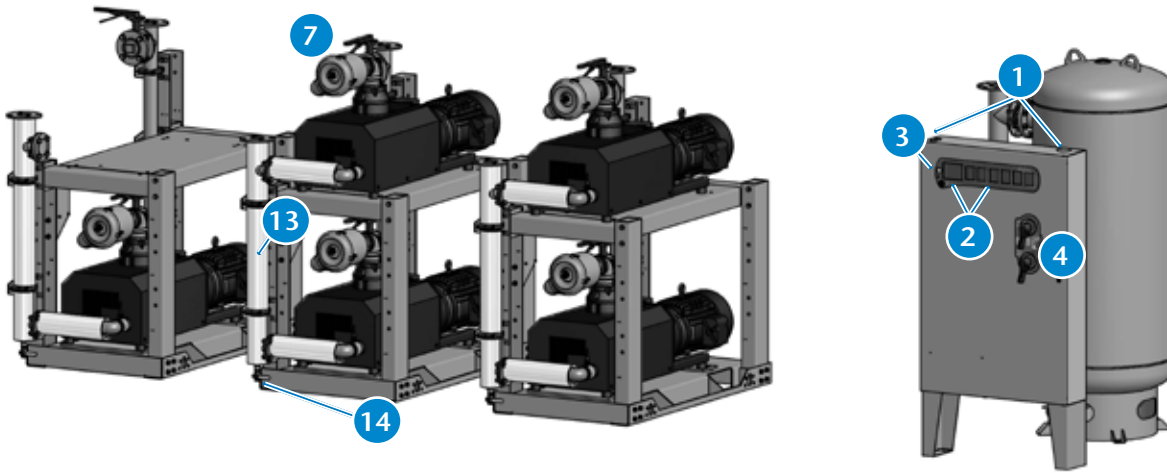

- 1 Control panel pre-drilled for power, alarms, and Ethernet connections for easy electrical installation.
- 2 TotalAlert Embedded touch screen controls featuring 5.7" master screen and (5) 3.5" operating screens with exceptional clarity and visibility.
- 3 Motion sensor to activate touch screen displays, preserving screen life.
- 4 Through the door disconnects for pumps add to safety during service.
- 5 Flex connectors on vacuum inlet to isolate pump vibration from facility pipeline.
- 6 Oil sight glass and filler plug with ease of access for annual oil changes.
- 7 Individual 5 micron air inlet filter per vacuum pump to protect pump from incoming particulates.
- 8 Hospital connection and receiver inlet positioned below receiver exit and piping to the pumps - extra protection against liquids/debris entering pumps.
- 9 Full-size 3-valve receiver bypass with flanged valves reduce potential leak points over NPT fittings.
- 10 Vacuum switch as backup to vacuum transducer. In case of transducer failure, system operates effectively.
- 11 Flanges reduce piping connection time between modules.
- 12 Openings in base frame to allow access underneath pumps for pump maintenance.
- 13 Discharge manifold with connection to the exhaust piping, with flex hoses factory installed.
- 14 Factory installed exhaust drip leg with ball valve and condensate drain.

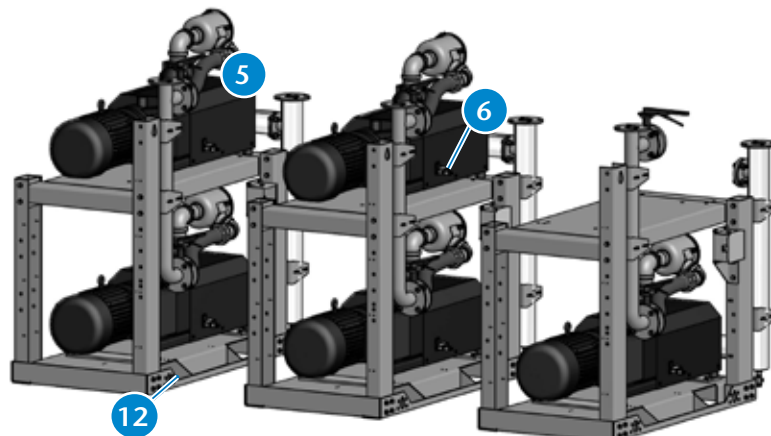
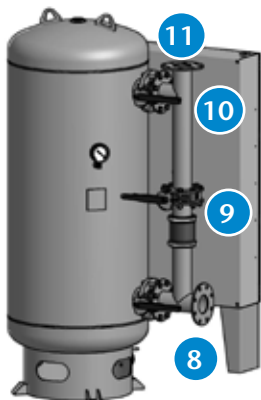

## TotalAlert Embedded Control System



### Touch Screen Control

- Master screen is 5.7" high resolution LCD with 640x480 pixel display and Unit screens are 3.5" high resolution LCD with 240x320 pixel display for exceptional clarity and visibility
- Toolbars on all screens with easy access navigation icons that enable full access with minimal touches
- Passive InfraRed (PIR) motion sensor activates screen display (under alarm conditions screen is active continuously)

### Ethernet Connectivity with Embedded Web Page

- Built-in web server allows remote operator to view system controls and display information
- Ethernet communication compatible with TotalAlert and TotalAlert<sup>2</sup> alarm systems
- Web page provided to show links to other devices on the TotalAlert Embedded network, including alarms and other source equipment
- Electronic notification
  - » Accessible through any SMTP gateway
  - » Allows for remote alerts of alarm and warning conditions
  - » Allows for remote alerts of routine maintenance
- All printed circuit boards have an Ethernet port that allows reprogramming with a standard computer for software updates
- Dual Ethernet configuration with separate Ethernet subnets to separate the facility Ethernet from internal TotalAlert Embedded communications

### Control Cabinet Safety

- Volt free relay contacts for all standard alarms
- Low voltage (24V) control circuit
- Full voltage motor starters with overload protection
- Circuit breaker disconnects for each vacuum pump
- Backup vacuum switch
- In case of power failure at source, all remote alarm contacts open in alarm condition.

### Redundancy

- In unlikely event of display boards or displays becoming disabled, unit will function normally and activate alarm
- If master board is disabled, system goes to failsafe operation with backup pressure switch
- Each vacuum pump has independent board for control allowing unit to function independently

### Master Display Screen (5.7")

- Main Screen
  - » Displays the system operating conditions, including Vacuum level
  - » Displays the vacuum pump sequence, including status of all pumps (running, available, off) and next to start
- Trends & Graphs
  - » Shows measured values of the system operating conditions over a period of time (vacuum level, ambient temperature)
  - » Selectable time periods consist of 60 min, 4 hrs, 24 hrs, and 6 days
- Service
  - » Displays ambient temperature in the room
  - » Maintenance screen shows suggested and required maintenance items with resettable timers
  - » Historical event log records all service activities
- Alarms and Shutdowns
  - » All System Alarms and Shutdowns displayed with visual indication (Green or Red)
  - » Testing mode enables operator to test all alarm events (password protected)
  - » Event History Log records all system event history excluding service/maintenance history
- System Settings
  - » Allows the adjustment of system vacuum operating range (password protected)
  - » Displays pertinent system model information

### Unit Screens (3.5") - One per Vacuum Pump

- Main Screen shows the operation mode of the unit along with the automatic or manual mode setting
- Unit status screen displays the running hour meter values
- Pump rotation allows the unit to run for a short period to check pump rotation
- All Unit Alarms and Shutdowns displayed with visual indication (Green or Red)
- Audible indication for unit Shutdown Alarms
- Testing mode enables operator to test of all shutdown events (password protected)

**Standard Configuration**

15 Hp Pentaplex Expandable to Hexaplex

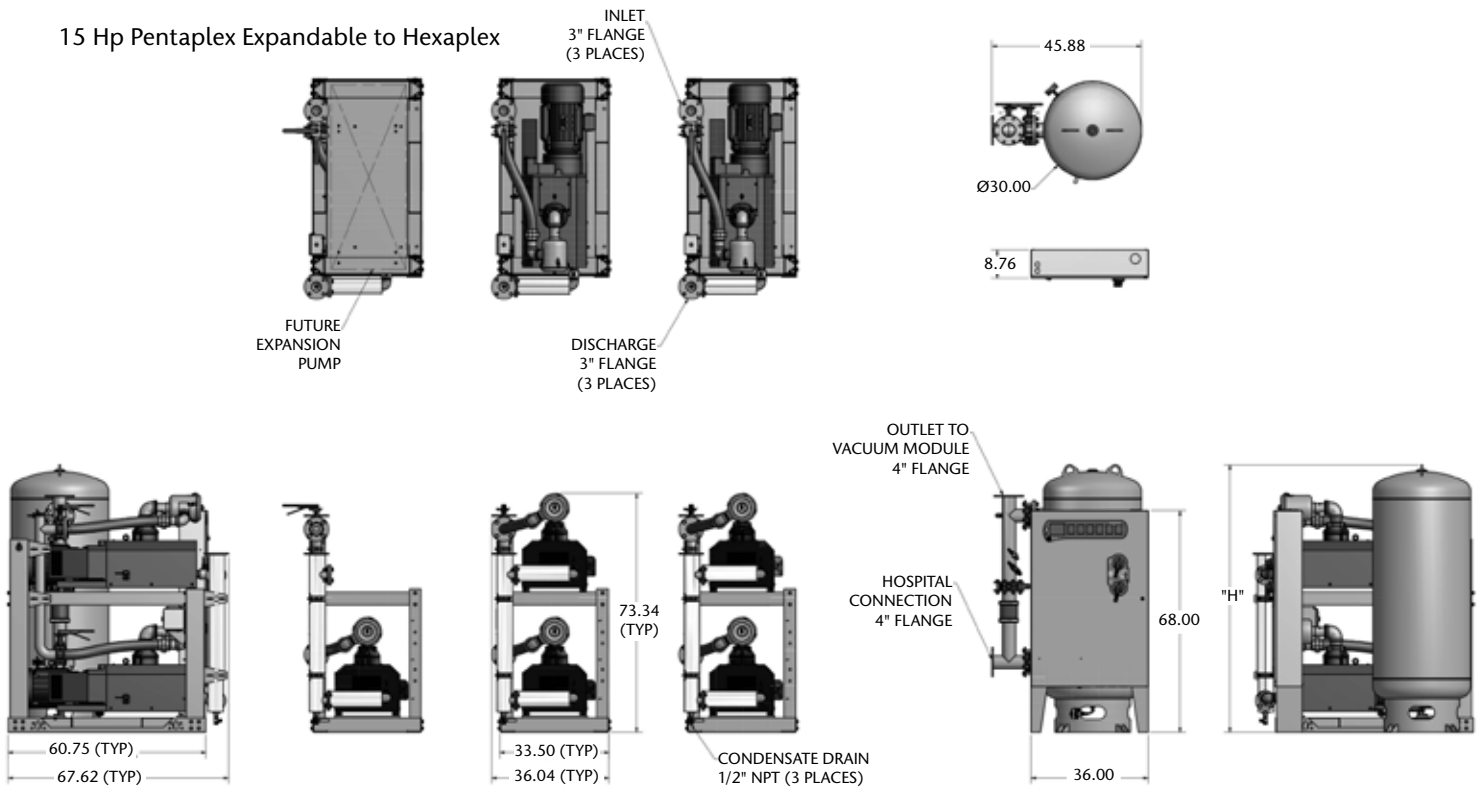

- Notes:**
- Discharge mufflers ship loose.
  - Allow 36 inches in front of control panel for maintenance and ventilation, all other sides require 24 inches of clearance.
  - Additional drawings/diagrams available for download at [www.beaconmedaes.com](http://www.beaconmedaes.com).

Vacuum System Specifications <sup>1</sup>										
System Model No.	HP	Capacity <sup>2</sup> @19" Hg (scfm)		System <sup>3</sup> BTU/HR	Receiver (gallons)	Noise <sup>4</sup> Level	System FLA	System Weight (lbs.)		Dimensions (in.)
		Pump	System				380V	Vacuum Module <sup>5</sup>	Receiver Module	H
VHM15P-200V-H	15	107	428 (535)	122,160 (152,700)	200	94	129.0	7,102	658	82.1
VHM15P-240V-H	15	107	428 (535)	122,160 (152,700)	240	94	129.0	7,102	733	94.1

- Notes:**
1. Normal operating conditions at a maximum ambient of 105° F. Consult factory for higher ambient conditions.
  2. All capacities are shown as NFPA system capacities (reserve vacuum pump on standby). All capacities reflect 50 Hz operation.
  3. All system BTU/HR are shown with reserve vacuum pump on standby.
  4. All noise levels are shown in dB(A) and reflect reserve pump on standby.
  5. Total weight for (3) duplex modules, includes future expansion pump, and a hexaplex control panel.
  6. Medical Vacuum System is not to be used in non-medical laboratory applications.