



OSA3000 Series

Open-Style Semi-Automatic Switchover Manifolds for High Pressure Cylinders (High Purity Applications)

Key Features

Endless Configurations

Our part number matrix allows you to easily configure your manifold the way you need it

Designed for High Pressure Cylinders

Max. Inlet Pressure: 3000 PSIG per bank

Check Valve in Each Hose/Pigtail

Prevents discharge of gas from manifold and hoses/pigtails when changing cylinders Prevents airborne contaminants from entering the gas delivery system during cylinder changeouts

Designed for High Flow Rate Applications

$C_v = 0.45$

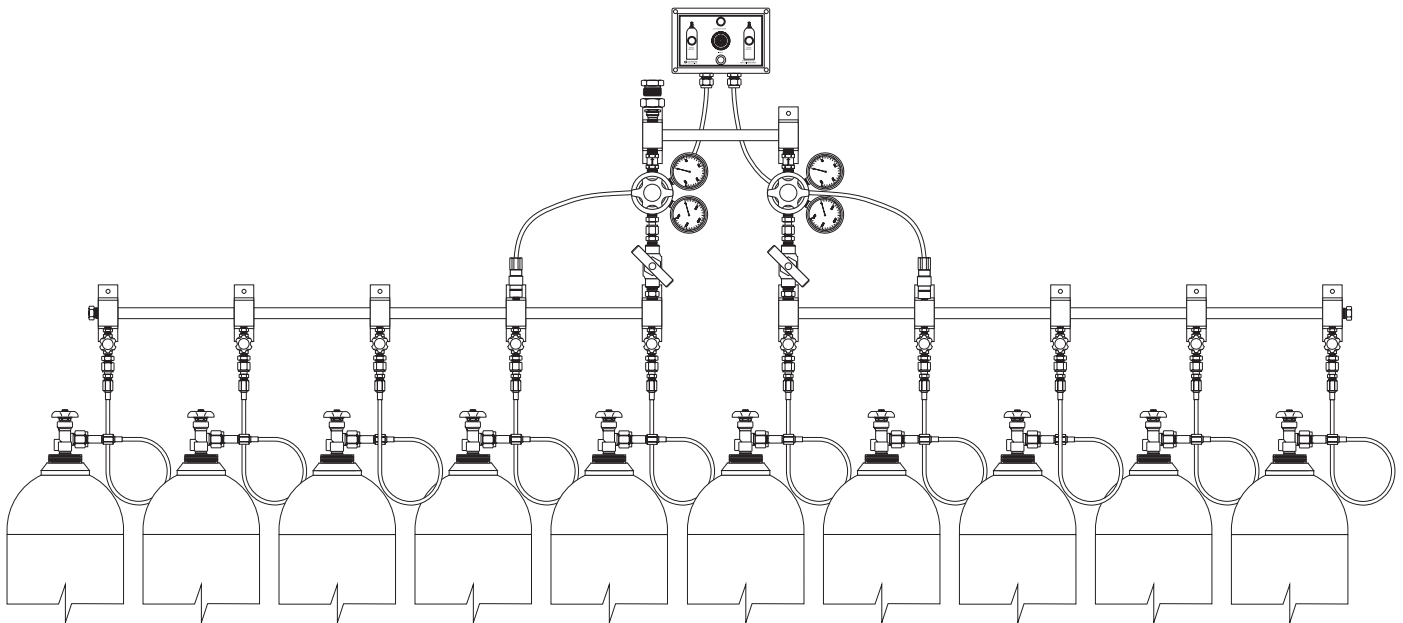

Open-Style Semi-Automatic Switchover Manifolds for High Pressure Cylinders (High Purity Applications)

Description

The system uses two high purity pressure reducing regulators. In order to have a switchover process take place, one regulator must be set at 10-15 psig higher than the other regulator. The gas will flow from the regulator having the highest set pressure. When the inlet pressure of the regulator set at the higher delivery pressure falls below the delivery pressure of the other regulator, the switchover will occur. Should you want to draw from this new cylinder bank, the delivery pressure of that regulator must be adjusted by an operator to 10-15 psig higher than the other regulator.

BeaconMedæus offers a remote alarm box as an option with all simplex manifolds. The alarm box is equipped with lights and an audible alarm to warn the operator when the bank pressure is low. The Nema 4 pressure switches are field adjustable.

The single stage, high purity and high flow pressure reducing regulators come standard with a stainless steel diaphragm. Should you require a different pressure reducing regulator style, please call BeaconMedæus to discuss.

Equipment Overview

FULLY AUTOMATIC SWITCHOVER MANIFOLD CONTROL & ALARM BOX

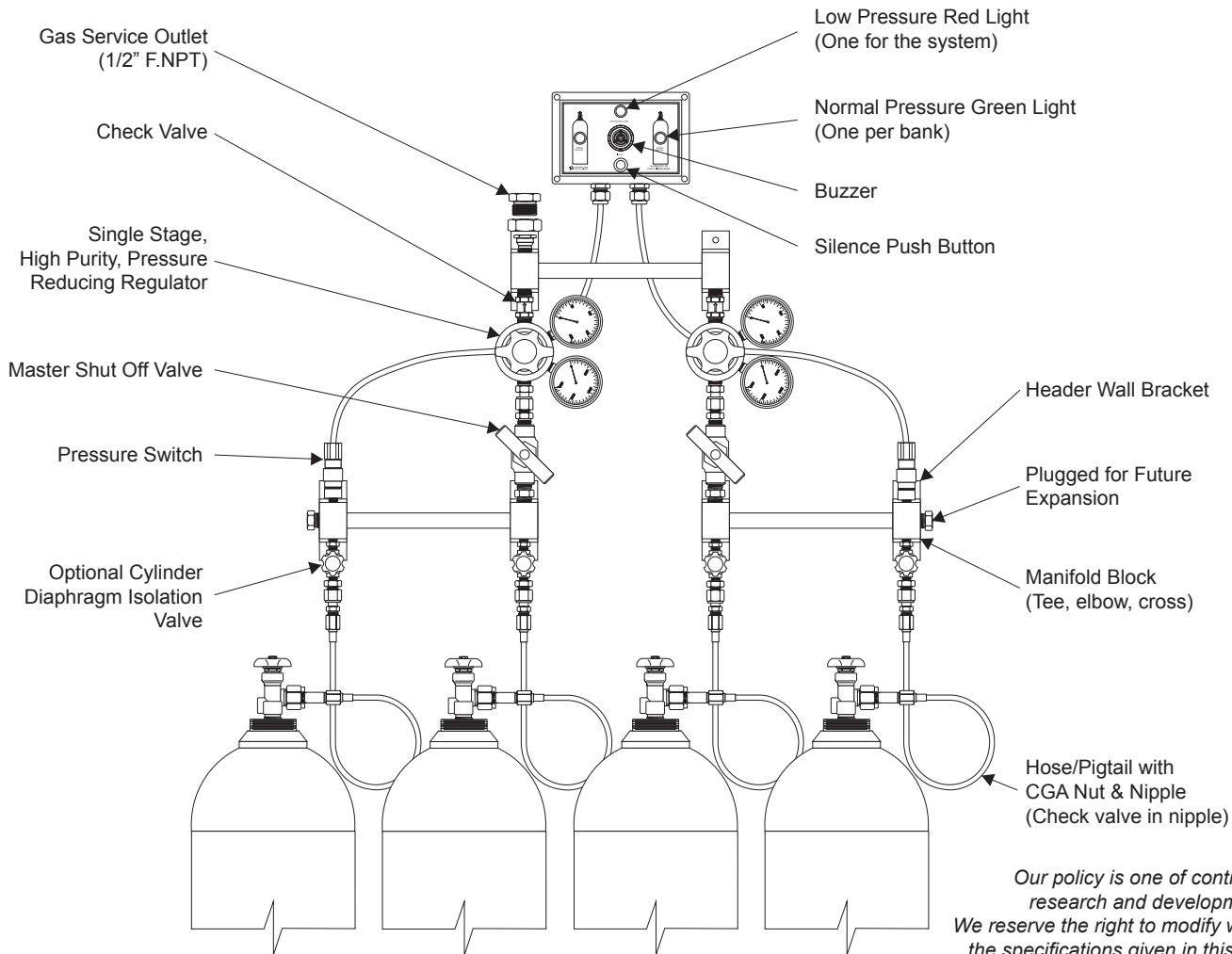

Open-Style Semi-Automatic Switchover Manifolds for High Pressure Cylinders (High Purity Applications)

Materials

Header	Brass ASTM B16 - CDA377
Fittings	Brass ASTM B16
Hoses	Thermoplastic Hoses: Innercore: Nylon - Fittings: Steel - Specs: SAE J517 100R8 - Color: Black Teflon Hose: Innercore: Teflon - Fittings: Brass - Braiding: Stainless Steel Stainless Steel Hoses: Core: Stainless Steel - Braiding: Stainless Steel - Fittings: Stainless Steel
Rigid Pigtails	Fittings: Brass - Tubing: Copper
Header Valve	Body: Brass UNS 37700 - Packing Nut: Stainless Steel 316 - Handle: Aluminum - Lower Packing Washer: Stainless Steel 316 - Packing: PTFE - Stem: Stainless Steel 316
Regulator	Body, Bonnet: Brass - Diaphragm: Stainless steel - Seal and Seat: PTFE - Filter: Sintered Bronze - Seat Return Spring: PH 17-7 Stainless Steel
Header Valve	Body: Brass UNS 37700 - Packing Nut: 316 Stainless Steel - Packing: PTFE - Handle: Aluminum Stem: 316 Stainless Steel - Upper Packing Washer: Brass
Pressure Switches	Piston: Stainless Steel - "O"-Ring: Buna-N - Connection: Brass
Isolation Valves	Body: Brass - Diaphragm: Stainless Steel - Seat: PCTFE
Check Valves	Body, Cap & Poppet: Brass - Spring: 316 Stainless Steel - Seat: Fluorocarbon Rubber

Specifications

Gas	Refer to part number matrix	Hose/Pigtail Length	36 inches
Maximum Inlet Pressure	3000 PSIG	Inlet Connections	Gas Specific CGA fittings
Power Requirement	110 VAC (for alarm box only)	Outlet Connections	1/2" F.NPT
Flow	Cv = 0.45	Audible & Visual Alarm	Optional
Operating Temperature	-40°F to + 100°F	Header	1/2" NPS
Outlet Pressure	10-125 PSIG (Other Delivery Pressures Available - Consult BeaconMedæx for Details)		

How it Works

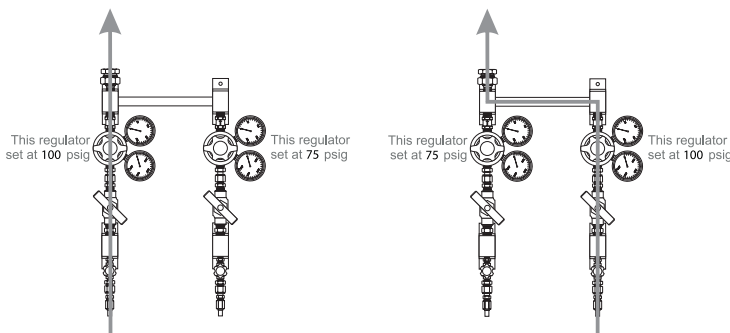

SUPPLY FROM LEFT BANK
The operator has to manually set the left bank regulator **25 psig higher** than the right bank regulator

SUPPLY FROM RIGHT BANK
The operator has to manually set the right bank regulator **25 psig higher** than the right bank regulator

Hose & Pigtail Length

Cylinder	36 inches
Bulk Pack/Cradle/Cluster	98 inches

Flow Data

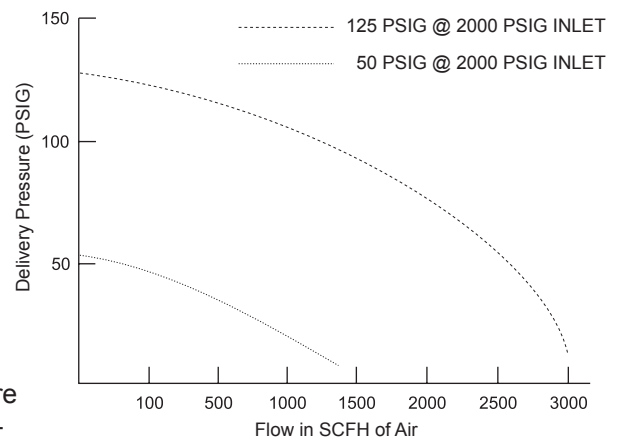

Ultra High Purity Applications (Option UHP)

OSA Series Manifolds are cleaned for oxygen service as a standard feature. For Ultra High Purity Applications, all manifold components are acid cleaned, rinsed with de-ionized water and purged with UHP nitrogen. For UHP applications, BeaconMedæx strongly recommends the use of all stainless steel rigid pigtails.

Open-Style Semi-Automatic Switchover Manifolds for High Pressure Cylinders (High Purity Applications)

Dimensions & Installation

Recommended Screw Types (to be supplied by installer)

	Wood Screws
	Drywall Screws with Self-Drilling Drywall Anchors
	Self Tapping Metal Screws
1/4" Ø are required	

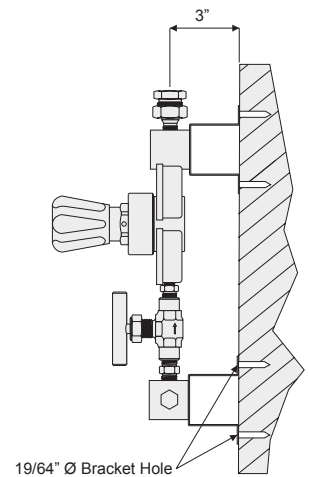
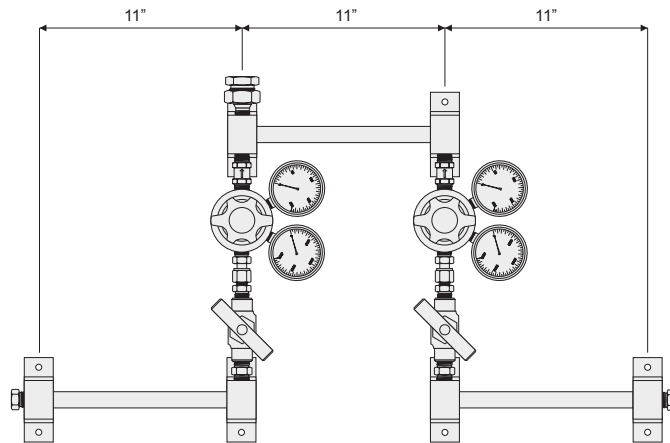

Ordering Information



Gas	Inscribe
Air-compressed	CGA 346
Argon	CGA 580
Argon mix	CGA 580
Carbon Dioxide*	CGA 320
Helium	CGA 580
Hydrogen	CGA 350
Argon/Methane	CGA 350
Nitrogen	CGA 580
Air - Industrial	CGA 590
Nitrous Oxide*	CGA 326
Oxygen	CGA 540
Other Gas: Provide CGA no.	

No. of Cylinders	Inscribe
Must be an even number to have the same quantity of cylinders per side (2 cyl. each side = 4)	

Alarm Box	Inscribe
Manifold with alarm box	AB
Manifold without alarm box	Leave Blank

Options	Inscribe
Vent Valve	VV
Outside Installation	3R
Ultra High Purity Cleaning	UHP
Cylinder Isolation Valve	CIV

Hoses & Pigtails	Inscribe
Teflon core hose	TCH
Thermoplastic hose	NCH
All stainless steel hose	SSH
Rigid copper pigtail	RCP
Rigid stainless steel pigtail	SSP

Installation Hardware	Inscribe
Wall mount bracket	WM
Floor Stand	FS

Header Style	Inscribe
Standard 10" center	10S
Staggered 5" center	5S
Vertical crossover 5" center	5V
Special (Please Provide Details)	SPX

*ELECTRIC TRIM HEATERS

Nitrous oxide and carbon dioxide manifolds come automatically with built-in gas heaters.