

Laboratory Air Oil-Free Scroll Compressor with Enclosure and 71G Tank (3 - 7.5 Hp)

SPECIFICATION

Enclosed Scroll Compressor

The laboratory air oil-free scroll compressor package is tank mounted and enclosed in a steel, sound-insulated canopy. The package is mounted upon a 71 gallon receiver tank. The compressor is designed and supplied as a complete package with all necessary equipment, including but not limited to the following components:

- Inlet filter
- Air compressor element
- Drive motor
- Aftercooler
- Starter and regulation system
- Control panel

All compressor components are mounted within a common six-sided low sound enclosure with solid base frame.

The enclosed scroll package provides air quality that qualifies to be in the category "Class 0" in terms of oil content as defined by standard ISO 8573-1:2001 Part 1.

Compressor Unit

Compressor Module: The compressor package is made up of one compressor module consisting of a compressor element belt driven by an electric motor, and radial fan. The module is equipped with a temperature sensor to monitor the element housing temperature.

Compression Element: The compressor element consists of a fixed scroll housing and an orbiting scroll rotor. The element and housing are pressure die cast aluminum. The crankshaft and pulley are cast iron. The element is V-belt driven using belts with XPZ profile. Bolts for adjusting belt tension are easily accessible via removable panels.

Drive Motor: The compressor module is belt driven by an IE3 NEMA Premium Efficiency, Totally Enclosed Fan Cooled motor for optimum performance and reliability. The motor insulation is Class F. The motor bearings are greased for life and do not require special attention.

Cooling System: The compressor element is cooled by an integrated radial fan. The compressed air is cooled by an aluminum block aftercooler and an axial fan fitted on the motor shaft provides cooling for the aftercooler. A separate fan delivers cooling air for the dryer.

Control Panel: The control panel comprises a pressure gauge, an hour meter, a start button and a temperature gauge indicating the dew point. The compressor is started and stopped automatically by a pressure switch. The electrical components are located in the cubicle behind the front panel door.

Starter: The compressor is factory equipped with a direct on line starter. The starter is mounted and wired within the UL listed compressor control cubicle.

Regulation System: The compressor regulation system keeps the net pressure between manually set limits by starting and stopping the compressor module.

Compressor Protection: The compressor contains a temperature shut-down switch and safety valve to protect the compressor against overheating and over-pressure. A check valve prevents blow-back of compressed air when the compressor is stopped.

Inlet Air Filter

A paper cartridge type filter is provided and factory installed. The filter eliminates dust and particles down to 1 µm.

Compressor Enclosure

The compressor module is enclosed in a steel, sound-insulated canopy with removable panels to provide access for maintenance. The sound insulating material is a flame retardant polyurethane.

Receiver Tank

The compressor is mounted upon an internally coated 71 gallon (270 liter) horizontal receiver. The receiver is provided with a manual drain valve or an electronic condensate drain as an option.

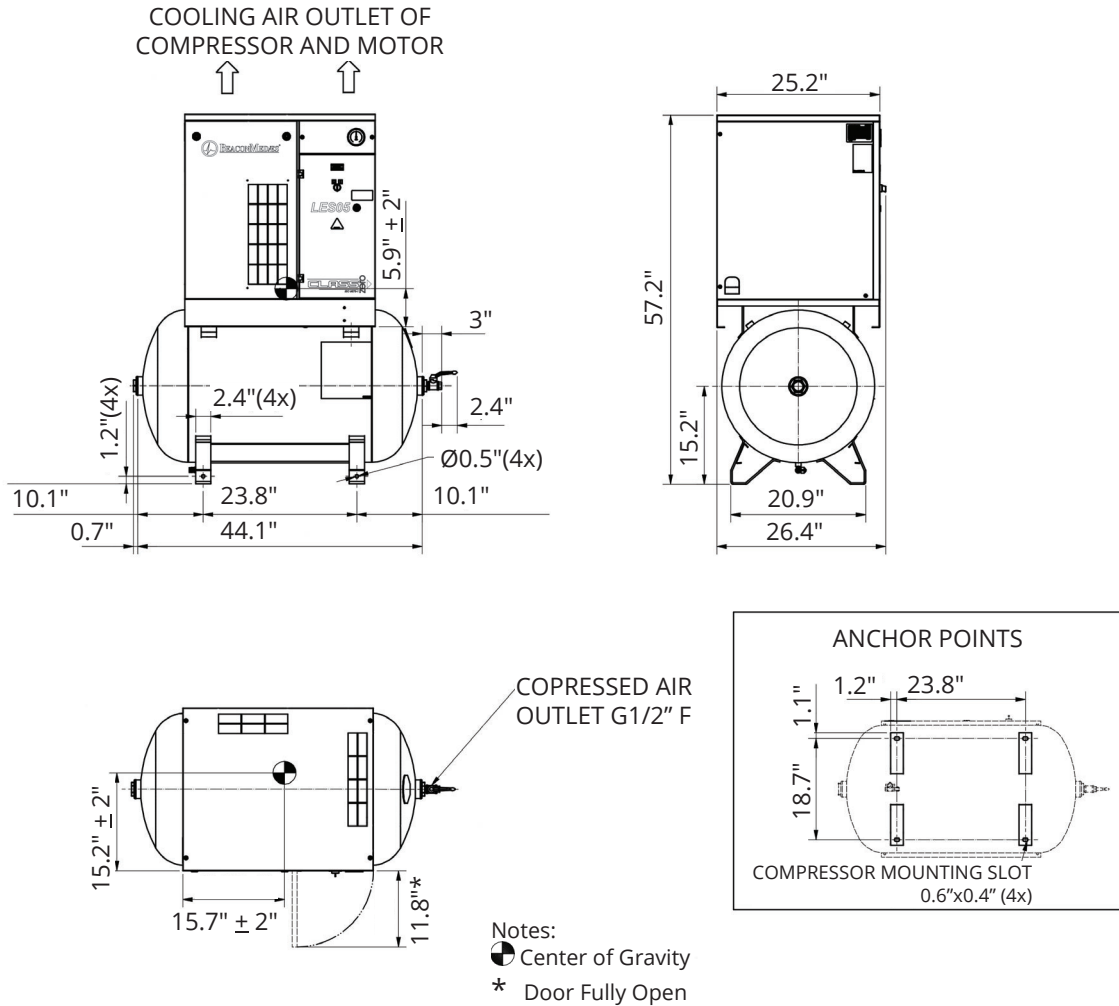

Scroll Compressor Package Specifications

System Model No.	HP	Max. Working Pressure (psig)	Effective Working Pressure (psig)	Capacity FAD ¹ (cfm)	Noise Level ²	Package FLA					Weight (Lbs.)
						208V 60 Hz	230V 60 Hz	460V 60 Hz	400V 50 Hz	230V 50 Hz	
LES03-115T-ND-071	3	116	101.5	8.9	56	10.1	9.1	4.6	5.6	9.7	452
LES03-145T-ND-071	3	145	130.5	7.2	56	10.1	9.1	4.6	5.6	9.7	452
LES05-115T-ND-071	5	116	101.5	14.0	58	17.3	15.9	8.0	9.1	15.7	470
LES05-145T-ND-071	5	145	130.5	12.5	58	17.3	15.9	8.0	9.1	15.7	470
LES08-115T-ND-071	7.5	116	101.5	20.8	59	25.0	24.0	12.0	13.4	23.3	523
LES08-145T-ND-071	7.5	145	130.5	16.1	59	25.0	24.0	12.0	13.4	23.3	523

Notes: 1. Unit performance measured according to ISO 1217, Annex C, latest edition. Reference conditions: Absolute inlet pressure 14.5 psig; intake air temperature 68° F.
 2. Noise level measured at a distance of 1m according to Pneuop/CAGI PN8NTC2 test code.