

Electrical Receptacles and Accessories

SPECIFICATION

Electrical Receptacle Design

Electrical receptacles are provided with a die cast, light gray, epoxy powder coated trim plate and a solid anodized aluminum insert plate to match wall/ ceiling mounted medical gas outlets. All electrical accessories utilize UL/CSA recognized hospital grade receptacles.

Electrical receptacles are Hubbellock 23000HG, 20A, 125V, twistlock or hospital grade straight blade duplex receptacles (NEMA 5-15R) 15A, 125V, gray, or (NEMA 5-20R) 20A, 125V, red or ivory.

Rough-in Assembly

The rough-in assembly for electrical receptacles consists of a galvanized 4" square x 2" deep electrical box attached to a 16-gauge steel mounting plate with yellow chromate on zinc plating and a galvanized 5/8" raised single device cover. The rough in assembly is of a modular design to permit on site ganging of multiple electrical accessories and/or **BeaconMedaes** gas outlets in any order on 5" centerline spacing.

Blank Spacers

Blank spacers are used to increase centerline spacing between services to 10". The rough-in assembly for blank spacers consists of a 16-gauge steel mounting plate with yellow chromate on zinc plating. The rough in has a 3/8" high metal plaster flange and is designed to gang mount with other medical gas or electrical accessories. The blank spacer has a solid anodized aluminum insert plate and die cast, light gray, epoxy powder coated trim plate to match wall/ ceiling mounted medical gas outlets and electrical accessories.

Future Electrical Provision

The future electrical provision allows the customer to install electrical devices such as telephone, data or monitoring receptacles and maintain the same cover plate design as the **BeaconMedaes** medical gas and electrical accessories. The rough-in assembly consists of a galvanized 4" square x 2" deep electrical box attached to a 16-gauge steel mounting plate with yellow chromate on zinc plating and a galvanized 5/8" raised single device cover. The rough in assembly is of a modular design to permit on site ganging of multiple electrical accessories and/or **BeaconMedaes** gas outlets in any order on 5" centerline spacing. The future electrical provision has a solid anodized aluminum insert plate and die cast, light gray, epoxy powder coated trim plate to match wall/ ceiling mounted medical gas outlets and electrical accessories.

Description	Color	Complete Assembly Part Number
Hubbellock 23000HG 20A, 125V (TWISTLOCK)	Gray	<input type="checkbox"/> 120970-00
Hospital Grade Straight Blade Duplex Receptacle, 15A, 125V (NEMA 5-15R)	Gray	<input type="checkbox"/> 120972-00
Hospital Grade Straight Blade Duplex Receptacle 20A, 125V (NEMA 5-20R)	Red Ivory	<input type="checkbox"/> 120973-00 <input type="checkbox"/> 120975-00
Blank Spacer		<input type="checkbox"/> 120979-00
Future Electrical Provision		<input type="checkbox"/> 120969-00

Electrical Receptacles and Accessories

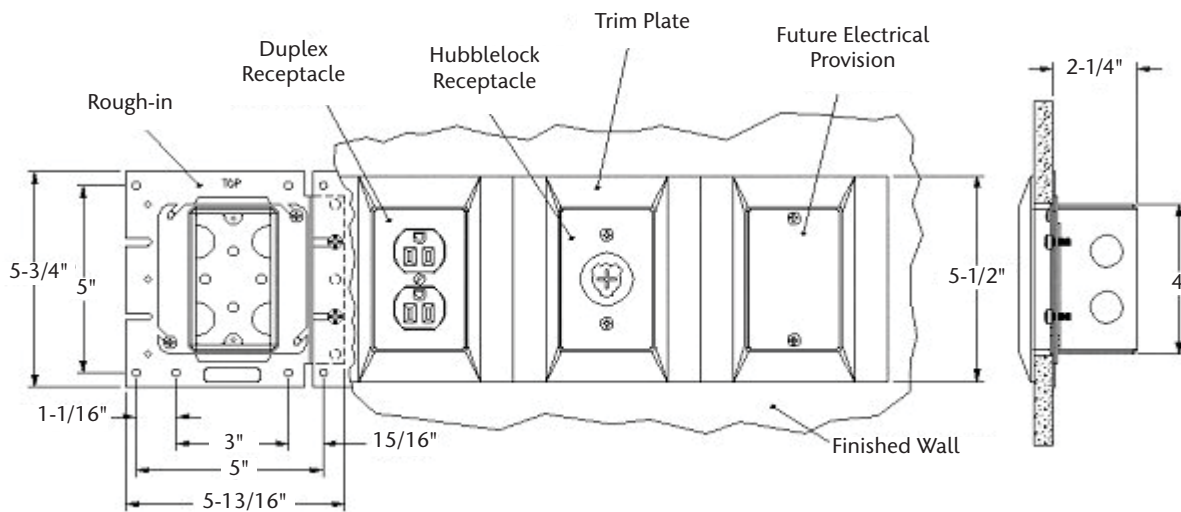
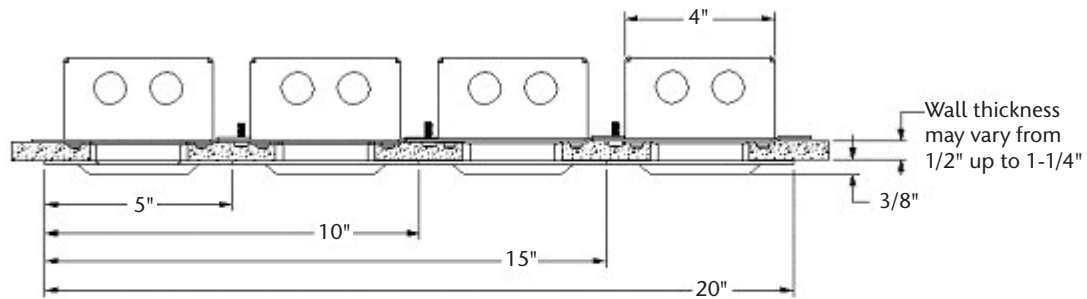

NOTE: A maximum of three devices may be ganged without additional support

