

LifeLine® "Oil-Less" Medical Rotary Vacuum Tankmount Duplex System (1.5 - 2 HP)

SPECIFICATION

Vacuum System Design

The LifeLine® "Oil-Less" Rotary Vane Medical vacuum package is fully compliant with NFPA 99 and features single point connections for the electrical panel and intake. Each pump and the receiver are connected to a common intake manifold. The system is capable of access through a standard 34.5" doorway. Designed and manufactured with ISO 13485 processes, each system is completely tested before shipment and includes:

- Two "oil-less" rotary vane vacuum pumps with two motors
- Integral pre-wired control panel
- Horizontal air receiver with full-size three-valve bypass system sized for appropriate demand

Vacuum Pump

Each pump is a direct driven, oil-less rotary vane vacuum pump that operates completely dry. Each pump is completely air-cooled with no water requirements. Each pump contains:

- Self-lubricating carbon/graphite vanes
- Permanently lubricated and sealed bearings
- Inlet filter for removal of particulates
- Equipped with a vacuum relief valve, check valve to prevent backflow through off-cycle units, flexible connector, and isolation valve
- Mounting on vibration isolators

Vacuum Pump Drive

Each pump is direct driven. Torque is transmitted from the motor to the pump through a shaft coupling.

Vacuum Pump Motor

Motors are continuous duty, IEC rated, C-face, foot-mounted, TEFC, 1800 RPM, suitable for 230/460 or 208V, 60 hertz, 3-phase electrical service.

Intake Piping

Each vacuum pump has a factory piped intake with integral flex connector, isolation valve, and check valve. Interconnecting piping consists of galvanized pipe and fittings.

Vacuum Receiver

The vacuum receiver is ASME Code stamped, and rated for a minimum 150 PSIG design pressure.

The receiver has a full-size three-valve bypass system to allow for draining of the receiver without interrupting the vacuum service. A manual drain is provided on the receiver.

Control System

The duplex mounted and wired control system is U.L. labeled. The control system provides automatic lead/lag sequencing. A programmable logic controller (PLC) controls the automatic alternation of both vacuum pumps with provisions for simultaneous operation if required. Automatic activation of reserve unit, if required, activates an audible alarm as well as a visual alarm on the control panel. The control system includes an automatic run timer.

Additional components include:

- NEMA 12 control panel enclosure
- Circuit breaker disconnects for each motor with external operators
- Full voltage motor starters with overload protection
- 24V control circuit
- Visual/audible reserve unit alarm with isolated contacts for remote alarm
- Hand-Off-Auto lighted selected switches
- Runtime hourmeters
- Vacuum gauge

Installation

The installation of this vacuum technology is limited to a maximum of 4,000 feet elevation above sea level. For installation of this equipment above 4,000 feet elevation, please contact the factory.

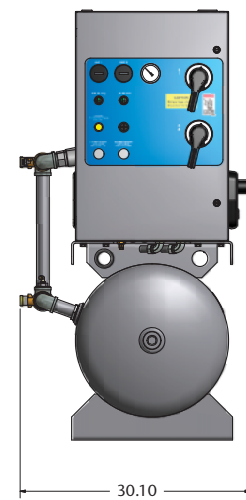
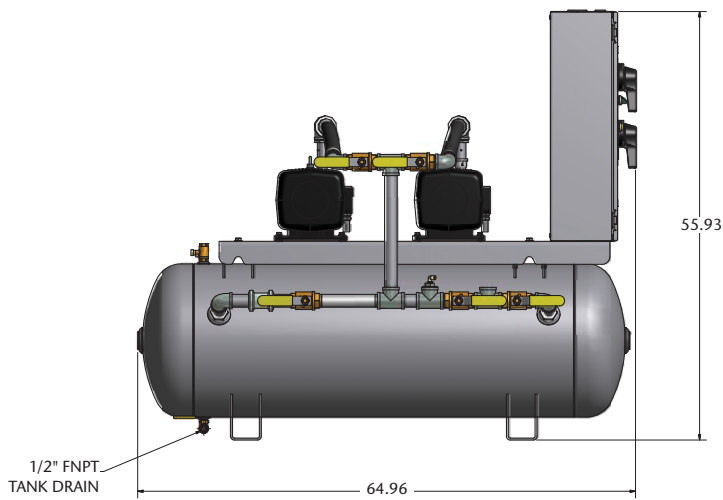
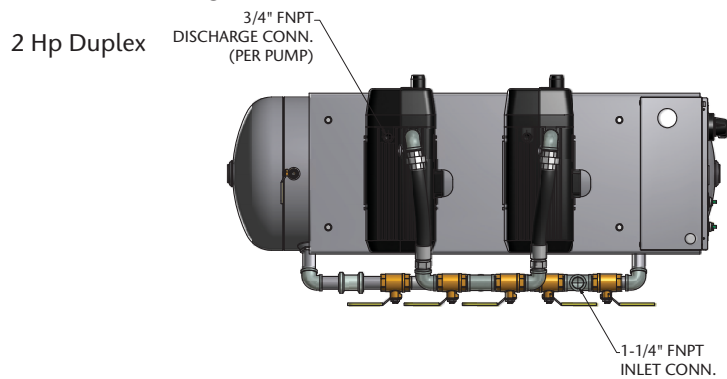
Standard Configuration

- Notes:**
- Allow 36 inches in front of control panel for maintenance and ventilation, all other sides require 24 inches of clearance.
 - Discharge flex hoses (2) ship loose.
 - Additional drawings/diagrams available for download at www.beaconmedaes.com.

Vacuum System Specifications ¹										
System Model No.	HP	Capacity ² @19" Hg (scfm)		System ³ BTU/HR	Receiver (gallons)	Noise ⁴ Level	System FLA			System Weight (lbs.)
		Pump	System				208V	230V	460V	
VDT01D-080H-BD	1.5	5	5	3,054	80	67	11.8	11.3	6.2	613
VDT02D-080H-BD	2	8	8	4,072	80	70	15.6	14.2	7.4	667

- Notes:**
1. Normal operating conditions at a maximum ambient of 105° F. Consult factory for higher ambient conditions.
 2. All capacities are shown as NFPA system capacities (reserve vacuum pump on standby).
 3. All system BTU/HR are shown with reserve vacuum pump on standby.
 4. All noise levels are shown in dB(A) and reflect reserve pump on standby.