

LifeLine[®] “Oil-Less” Reciprocating Medical Air Tank Mount Duplex System (2.4 – 6.4 HP)

SPECIFICATION

Tank Mount Design

The LifeLine[®] Oil-Less Reciprocating Medical air package is fully compliant with NFPA 99 and features single point connections for electrical, intake air, discharge air, and condensate drains. Designed and manufactured with ISO 13485 processes, each system is completely tested before shipment and includes:

- Two “oil-less” reciprocating compressors, each with a direct drive motor
- Duplex desiccant drying system with purge control
- Integral pre-wired control panel
- Corrosion resistant horizontal air receiver

Compressor Module

The compressor design is air-cooled, single stage, two cylinder piston compressor with permanently lubricated, sealed bearings.

- Cylinders are nickel plated aluminum to achieve maximum heat dissipation
- Piston is anodized aluminum with teflon hardcoat and teflon carbon composite piston rings
- Heavy duty, sealed ball bearings are greased for life
- Inlet/outlet disc valves are stainless steel flexible annular discs
- Die cast aluminum crankcase and finned cylinder heads feature high cooling characteristics
- High capacity cooling fan contained in protective fan cowl, providing optimal direct cooling of the cylinders and aftercooler/intercooler
- Combined finned die-cast aluminum outlet cooler and finned copper aftercooler pipe
- Dynamically balanced crankshaft and heavy-weight cast iron cooling fan reduce vibration
- Direct drive, flanged on electric motor for increased efficiency

Compressor Motor

The motor is flange-mounted, IP55, that operates at 1700 RPM suitable for 208-230/460V 60 Hz. For 380V 50 Hz option, motor operates at 1500 RPM.

Compressor Assembly

Each compressor has a separate inlet filter and isolation valve. The isolation valves are piped to one common inlet connection. Each cylinder head is equipped with a high discharge air temperature shutdown switch wired to the compressor control system. The compressor discharge assembly includes:

- Integral air-cooled aftercooler with a maximum approach temperature of 15° F above ambient and integrated drain trap with automatic solenoid drain valve (6.4 Hp only)
- Safety relief valve, a check valve, and an isolation valve
- Discharge of each compressor is piped into one common discharge line manifold by way of a braided, 304 stainless steel flex connector

Isolation System

The compressor and motor are fully isolated from the receiver by means of a three-point, heavy duty, anti vibration pad system for a minimum of 80% isolation efficiency. Seismic restraint option is available.

Air Receiver

Corrosion resistant, ASME Coded, National Board Certified horizontal air receiver rated for minimum 200 PSIG design pressure. The air receiver assembly includes:

- Zero Loss electronic drain valve, liquid level gauge glass, safety relief valve, and manual drain valve
- Piped 3-valve bypass assembly with flange-fitted valves
- Pressure gauge

Dryer/Filter/Regulator System

Each desiccant dryer is sized for peak calculated demand and produces a 10° F (-12° C) pressure dew point. Each dryer operates from a demand based purge saving control system featuring repressurization cycles. The dryer assembly includes the following mounted and piped:

- 441™ transfer valve utilizing two sliding ceramic plates with a 5-year warranty
- High efficiency coalescing prefilter rated for 0.01 micron with automatic drain and element change indicator
- Fully duplexed final line particle filters rated for 1 micron with element change indicators
- Duplexed final line regulators and safety relief valves
- Ceramic type dew point sensor with ± 2° F system accuracy
- CO Sensor with ± 2 PPM (at 10 PPM) system accuracy

TotalAlert Embedded Control System

The duplex mounted and wired TotalAlert Embedded control system is U.L. labeled. The control system provides automatic lead/lag sequencing and automatic alternation of both compressors based on first-on/first-off principle with provision for simultaneous operation if required.

- NEMA 12 control panel enclosure
- Circuit breaker disconnects for each motor with external operators
- Full voltage motor starters with overload protection
- 24V control circuit
- 65kAIC SCCR rating

The touch screen controls feature one 5.7” master screen and a 3.5” operating screen for each compressor. Screen displays and functions include:

- Service alerts, runtime hourmeters, system status, system pressure level, dew point level, CO level
- Visual/audible alarm indications with isolated contacts for all standard remote alarms
- Event log recording alarms and system activity
- Event log recording service warnings and service history
- Trend graphs for outlet pressure, Dew Point, CO, and ambient temperature
- Ethernet connectivity and embedded web page for remote monitoring
- Electronic notifications of alarms and warnings
- Integral connectivity to the TotalAlert medical gas network via Ethernet
- Optional BACnet communication with TCP/IP protocol

Standard Configuration

Model Shown: 6.4 HP Duplex

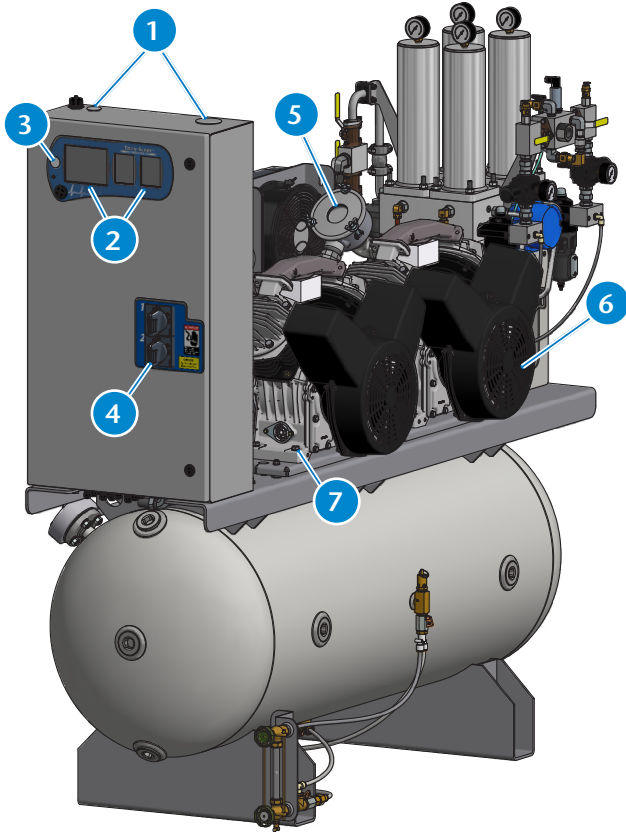

- 1 Control panel pre-drilled for power and alarms for easy electrical connections. Ethernet connection on panel top for easy installation.
- 2 TotalAlert Embedded touch screen controls featuring 5.7" master screen and 3.5" operating screens with exceptional clarity and visibility.
- 3 Motion sensor to activate touch screen displays, preserving screen life.
- 4 Through the door disconnects for compressors add to safety during service.
- 5 Individual air inlet filter per compressor to protect compressors from incoming debris.
- 6 Direct drive, flanged on electric motor eliminates transmission losses and increases efficiency up to 3%.
- 7 3-point heavy-duty isolation system for isolation efficiency of compressor. Further vibration isolation achieved with flex hoses on intake and discharge.

- 8 Zero-Loss electronic discharge drain to save compressed air and remove moisture efficiently.
- 9 Manifold dryer block design with SAE fittings to reduce potential leak points and to reduce pressure drop losses.
- 10 441® ceramic plate dryer switching valve with 150 million cycle anticipated life to reduce maintenance and downtime costs.
- 11 Anodized aluminum blocks and flanged fittings utilized throughout air stream design to reduce leak points.
- 12 Dryer towers with repressurization cycle to eliminate desiccant shock and minimize desiccant dusting.
- 13 High efficiency inlet and outlet filters to protect the desiccant beds and medical air stream.

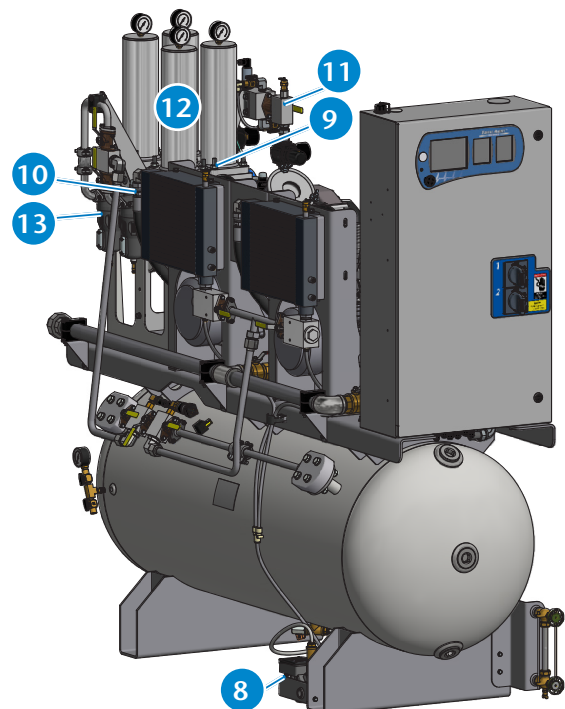

TotalAlert Embedded Control System

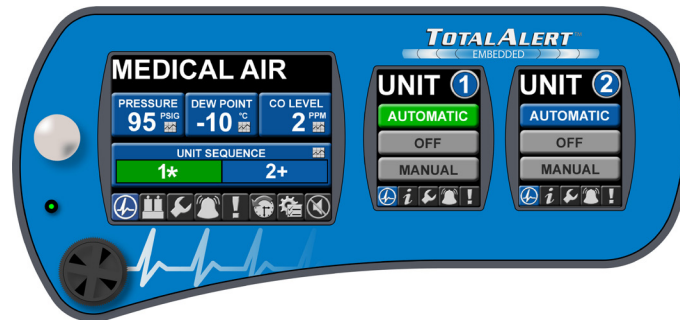

Touch Screen Control

- Master screen is 5.7" high-resolution LCD with 640x480 pixel display and Unit screens are 3.5" high-resolution LCDs with 240x320 pixel display for exceptional clarity and visibility
- Toolbars on all screens with easy access navigation icons that enable full access with minimal touches
- PIR motion sensor activates screen display (under alarm conditions screen is active continuously)

Ethernet Connectivity with Embedded Web Page

- Built-in web server allows remote operator to view system controls and display information
- Ethernet communication compatible with TotalAlert and TotalAlert² alarm systems
- Web page provided to show links to other devices on the TotalAlert Embedded network, including alarms and other source equipment
- Electronic notification
 - » Accessible through any SMTP gateway
 - » Allows for remote alerts of alarm and warning conditions
 - » Allows for remote alerts of routine maintenance
- All printed circuit boards have an Ethernet port that allows reprogramming with a standard computer for software updates
- Dual Ethernet configuration with separate Ethernet subnets to separate the facility Ethernet from internal TotalAlert Embedded communications
- TCP/IP protocol for optional BACnet activation – part number 4107 5590 00

Control Cabinet Safety

- Volt free relay contacts for all standard alarms
- Low voltage (24V) control circuit
- Full voltage motor starters with overload protection
- Circuit breaker disconnects for each compressor
- 65kAIC SCCR rating

Redundancy

- In unlikely event of display boards or displays becoming disabled, unit will function normally and activate alarm
- If master board is disabled, system goes to failsafe operation with backup pressure switch
- Each compressor and dryer unit has an individual board for control allowing unit to function independently

Master Display Screen (5.7")

- Main Screen
 - » Displays the system operating conditions, including System Pressure, Dew Point and CO level
 - » Displays the compressor unit sequence, including status of compressors (running, available, off) and next to start
- Trends & Graphs
 - » Shows measured values of the system operating conditions over a period of time (operating pressure, Dew Point, CO, ambient temperature)
 - » Selectable time periods consist of 60 min, 4 hrs, 24 hrs, and 6 days
- Dryer Information
 - » Displays the operating mode of the dryer(s)
 - » Displays dryer image showing current status
- Service
 - » Displays ambient temperature in the room
 - » Maintenance screen shows suggested and required maintenance items with resettable timers
 - » Historical event log records all service activities
- Alarms and Shutdowns
 - » All system Alarms and Shutdowns displayed with visual indication (Green or Red)
 - » Testing mode enables operator to test all alarm events (password protected)
 - » Event History Log records all system event history
- System Settings
 - » Allows the adjustment of system pressure operating range (password protected)
 - » Displays pertinent system model information

Unit Screens (3.5") - One per Compressor Unit

- Main Screen shows the operation mode of the unit along with the automatic or manual mode setting
- Unit status screen displays the running hour meter values
- Pump rotation allows the unit to run for a short period to check pump rotation
- All unit Alarms and Shutdowns displayed with visual indication (Green or Red)
- Audible indication for unit Shutdown Alarms
- Testing mode enables operator to test all shutdown events (password protected)

Standard Configuration

2.4 Hp – 6.4 Hp Duplex
 (6.4 Hp Shown)

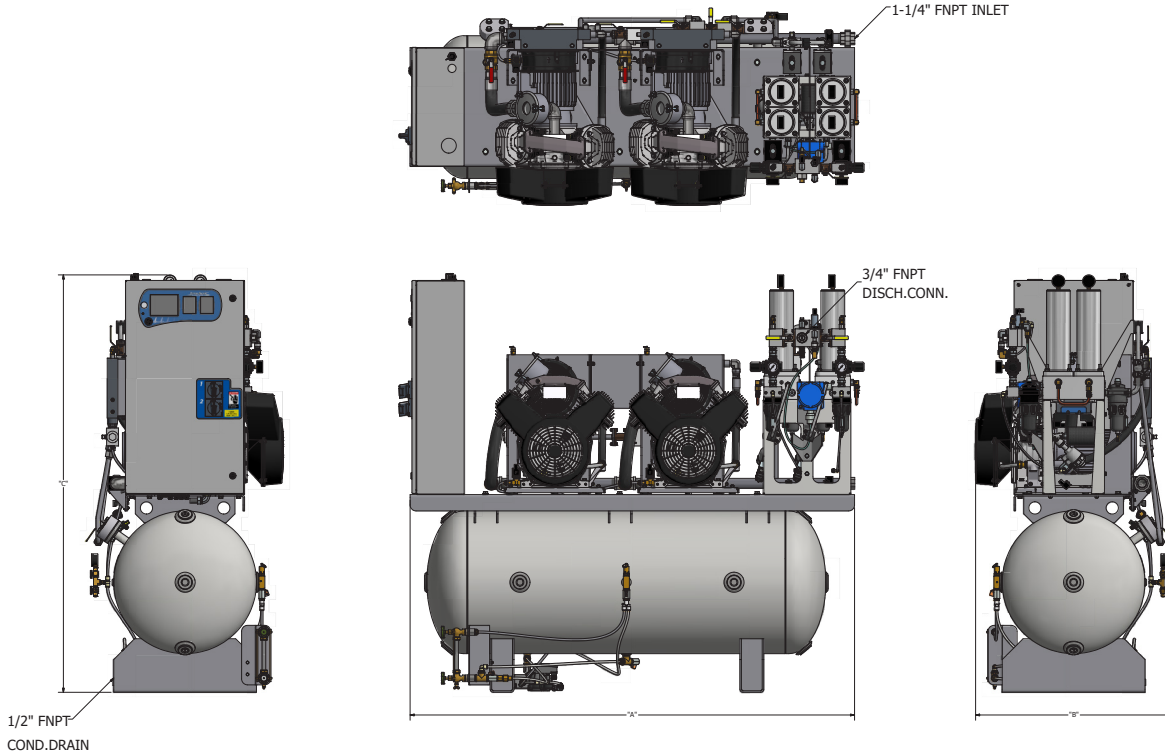

- Notes:**
- Discharge flex connections are built into package.
 - Allow 36 inches in front of control panel for maintenance and ventilation, all other sides require 24 inches of clearance.
 - Additional drawings/diagrams available for download at www.beaconmedaes.com.

Medical Air System Specification ¹															
System Model No.	HP/KW		System Capacity ² (SCFM)		System BTU ³ /Hr	Receiver (gallons)	Noise Level ⁴	System FLA				System Weight (lbs.)	Dimensions (in.)		
	60 HZ	50 HZ	60 HZ	50 HZ				208V	230V	460V	380V 50Hz		A	B	C
PAT02D-080H-D	2.4/1.8	2.0/1.5	7.6	6.6	4,885	80	84	15.8	14.9	7.6	7.6	982	74.75	31.48	66.2
PAT02D-120H-D	2.4/1.8	2.0/1.5	7.6	6.6	4,885	120	84	15.8	14.9	7.6	7.6	1,047	74.75	33.14	70.2
PAT03D-080H-D	3.5/2.6	3.0/2.2	9.7	8.5	7,124	80	85	24.0	21.7	11.0	11.2	1,001	74.75	31.48	66.2
PAT03D-120H-D	3.5/2.6	3.0/2.2	9.7	8.5	7,124	120	85	24.0	21.7	11.0	11.2	1,065	74.75	33.14	70.2
PAT06D-080H-D	6.4/4.8	5.4/4.0	19.3	16.1	13,027	80	85	41.6	37.7	19.0	18.6	1,085	74.75	31.48	66.2
PAT06D-120H-D	6.4/4.8	5.4/4.0	19.3	16.1	13,027	120	85	41.6	37.7	19.0	18.6	1,147	74.75	33.14	70.2

- Notes:**
1. Normal operating conditions at a maximum ambient of 105° F. Consult factory for higher ambient conditions.
 2. All capacities are shown as NFPA system capacities (reserve compressor on standby) and are shown in Standard Cubic Feet per Minute (SCFM), measured according to ISO 1217, Ed.3, Annex C-1996. Free Air Delivery is measured at working pressure of 100 psi.
 3. All system BTU/HR are shown with reserve compressor on standby.
 4. All noise levels are shown in dB(A) and reflect one compressor unit running.
 5. System is designed for output pressure of 50-60 psig (344-413 kPa). For alternate pressures contact factory.