

LifeLine® Lubricated Rotary Vane Medical Vacuum Single Point Connection (SPC) Duplex System (10 HP)

SPECIFICATION

Single Point Connection (SPC) System Design

The LifeLine® Lubricated Rotary Vane Medical vacuum package is fully compliant with NFPA 99 and features a common base with single point connections for the electrical panel, intake, and discharge. Each pump and the receiver are connected to a common intake manifold. Each pump is connected to a common discharge manifold. The common base is separable for transport through standard 34.5" doorway. Designed and manufactured with ISO 13485 processes, each system is completely tested before shipment and includes:

- Two oil-sealed rotary vane vacuum pumps with two motors
- Integral pre-wired control panel
- Vertical air receiver with full-size three-valve bypass system sized for appropriate demand

Vacuum Pump

Each pump is a direct driven, oil-sealed rotary vane vacuum pump, with an end (ultimate) vacuum of 29.3" Hg. Each pump is completely air-cooled with no water requirements. Each pump contains:

- Integral, fully recirculating oil supply to provide lubrication
- An automotive-type, spin-on oil filter for oil filtration
- High-discharge temperature switch
- Oil drain valve assembly with temperature gauge

The oil separation system is integral and consists of the following:

- No less than three stages of internally installed oil and smoke eliminators through which the exhaust gas stream must pass
- Bulk separation, oil mist elimination, and smoke elimination
- Capability to remove 99.9+ percent of all oil and smoke particles from the exhaust gas stream

Each vacuum pump includes the following:

- Built-in, anti-suck-back valve mounted at the pump inlet
- Three non-metallic, non-asbestos vanes, each having a minimum life of 30,000 hours
- 5 micron inlet filter for removal of particulates
- Mounting on vibration isolators
- Flexible connector and isolation valve

Vacuum Pump Drive

The pump shall be direct driven. Torque is transmitted from the motor to the pump through a shaft coupling.

Vacuum Pump Motor

Motors are continuous duty, NEMA rated, C-face, foot-mounted, TEFC, 1800 RPM, suitable for 230/460 or 208V, 60 hertz, 3-phase electrical service.

Intake Piping

Each vacuum pump has a factory piped intake with integral flex connector, isolation valve, and check valve. Interconnecting piping consists of powder-coated steel tubing and flanges.

Vacuum Receiver

The vacuum receiver is ASME Code stamped, and rated for a minimum 150 PSIG design pressure.

The receiver has a full-size three-valve bypass system to allow for draining of the receiver without interrupting the vacuum service. A manual drain is provided on the receiver.

Exhaust Piping

Each vacuum pump is factory piped with an integral flex connector to an exhaust manifold with a drip leg and ball valve for condensate drain. Interconnecting piping consists of powder-coated steel tubing and flanges.

TotalAlert Embedded Control System

The duplex mounted and wired TotalAlert Embedded control system is U.L. labeled. The control system provides automatic lead/lag sequencing and automatic alternation of vacuum pumps based on first-on/first-off principle with provision for simultaneous operation if required. Automatic activation of reserve unit, if required, will activate an audible alarm as well as a visual alarm on the display screen.

Additional components include:

- NEMA 12 control panel enclosure
- Circuit breaker disconnects for each motor with external operators
- Full voltage motor starters with overload protection
- 24V control circuit

The touch screen controls feature one 5.7" master screen and a 3.5" operating screen for each vacuum pump. Screen displays and functions include:

- Service alerts, runtime hourmeters for each pump, system status, system vacuum level
- Visual/audible alarm indications with isolated contacts for all standard remote alarms
- Event log recording alarms and system activity
- Event log recording service warnings and service history
- Trend graphs for vacuum level, pump operations, and ambient temperature
- Ethernet connectivity and embedded web page for remote monitoring
- Electronic notifications of alarms and warnings
- Integral connectivity to the TotalAlert medical gas network via Ethernet



Standard Configuration

10 HP Duplex

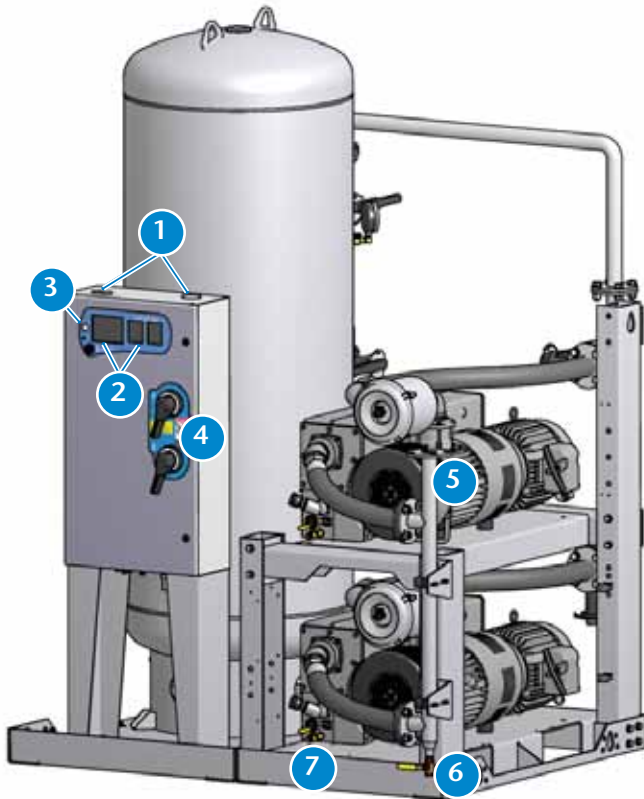

1 Control panel pre-drilled for power, alarms, and Ethernet connections for easy electrical installation.

2 TotalAlert Embedded touch screen controls featuring 5.7" master screen and (2) 3.5" operating screens with exceptional clarity and visibility.

3 Motion sensor to activate touch screen displays, preserving screen life.

4 Through the door disconnects for pumps add to safety during service.

5 Discharge manifold with a single point connection to the exhaust piping, with flex hoses factory installed.

6 Factory installed exhaust drip leg with ball valve and condensate drain.

7 Oil sight glass and filler plug with ease of access for oil changes.

8 Hospital connection and receiver inlet positioned below receiver exit and piping to the pumps - extra protection against liquids/debris entering pumps.

9 Full-size 3-valve receiver bypass with flanged valves reduce potential leak points over NPT fittings.

10 Vacuum switch as backup to vacuum transducer. In case of transducer failure, system operates effectively.

11 Easy to disassemble for transport through doorways and reassemble as Single Point Connection for installation.

12 Openings in base frame to allow access underneath pumps for pump maintenance.

13 Flex connectors on vacuum inlet and discharge to isolate pump vibration from facility pipeline.

14 Individual 5 micron air inlet filter per vacuum pump to protect pump from incoming particulates.

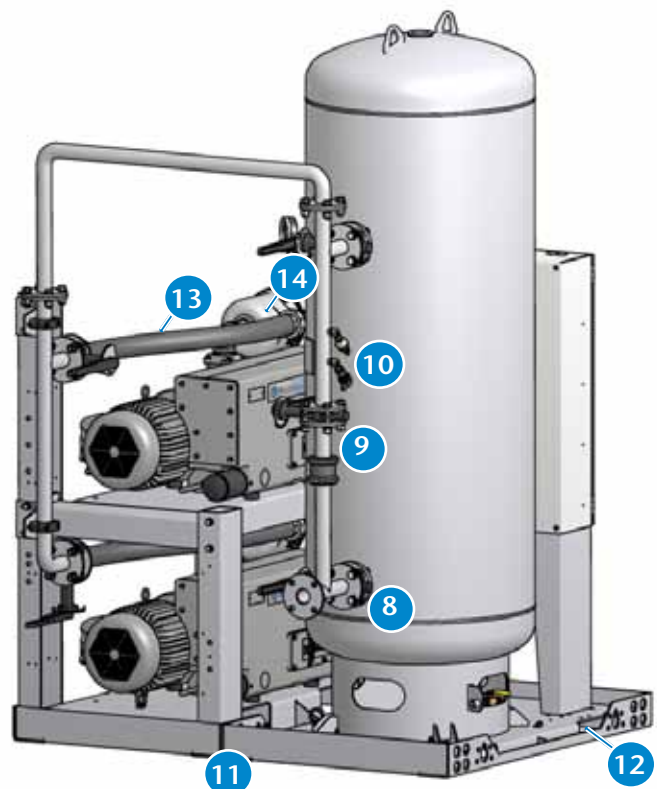

TotalAlert Embedded Control System

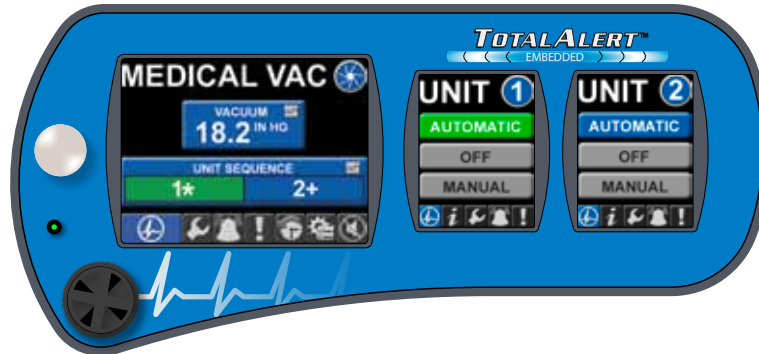

Touch Screen Control

- Master screen is 5.7" high resolution LCD with 640x480 pixel display and Unit screens are 3.5" high resolution LCD with 240x320 pixel display for exceptional clarity and visibility
- Toolbars on all screens with easy access navigation icons that enable full access with minimal touches
- Passive InfraRed (PIR) motion sensor activates screen display (under alarm conditions screen is active continuously)

Ethernet Connectivity with Embedded Web Page

- Built-in web server allows remote operator to view system controls and display information
- Ethernet communication compatible with TotalAlert and TotalAlert² alarm systems
- Web page provided to show links to other devices on the TotalAlert Embedded network, including alarms and other source equipment
- Electronic notification
 - » Accessible through any SMTP gateway
 - » Allows for remote alerts of alarm and warning conditions
 - » Allows for remote alerts of routine maintenance
- All printed circuit boards have an Ethernet port that allows reprogramming with a standard computer for software updates
- Dual Ethernet configuration with separate Ethernet subnets to separate the facility Ethernet from internal TotalAlert Embedded communications

Control Cabinet Safety

- Volt free relay contacts for all standard alarms
- Low voltage (24V) control circuit
- Full voltage motor starters with overload protection
- Circuit breaker disconnects for each vacuum pump
- Backup vacuum switch
- In case of power failure at source, all remote alarm contacts open in alarm condition.

Redundancy

- In unlikely event of display boards or displays becoming disabled, unit will function normally and activate alarm
- If master board is disabled, system goes to failsafe operation with backup pressure switch
- Each vacuum pump has independent board for control allowing unit to function independently

Master Display Screen (5.7")

- Main Screen
 - » Displays the system operating conditions, including Vacuum level
 - » Displays the vacuum pump sequence, including status of all pumps (running, available, off) and next to start
- Trends & Graphs
 - » Shows measured values of the system operating conditions over a period of time (vacuum level, ambient temperature)
 - » Selectable time periods consist of 60 min, 4 hrs, 24 hrs, and 6 days
- Service
 - » Displays ambient temperature in the room
 - » Maintenance screen shows suggested and required maintenance items with resettable timers
 - » Historical event log records all service activities
- Alarms and Shutdowns
 - » All System Alarms and Shutdowns displayed with visual indication (Green or Red)
 - » Testing mode enables operator to test all alarm events (password protected)
 - » Event History Log records all system event history excluding service/maintenance history
- System Settings
 - » Allows the adjustment of system vacuum operating range (password protected)
 - » Displays pertinent system model information

Unit Screens (3.5") - One per Vacuum Pump

- Main Screen shows the operation mode of the unit along with the automatic or manual mode setting
- Unit status screen displays the running hour meter values
- Pump rotation allows the unit to run for a short period to check pump rotation
- All Unit Alarms and Shutdowns displayed with visual indication (Green or Red)
- Audible indication for unit Shutdown Alarms
- Testing mode enables operator to test all shutdown events (password protected)

Standard Configuration

10 Hp Duplex

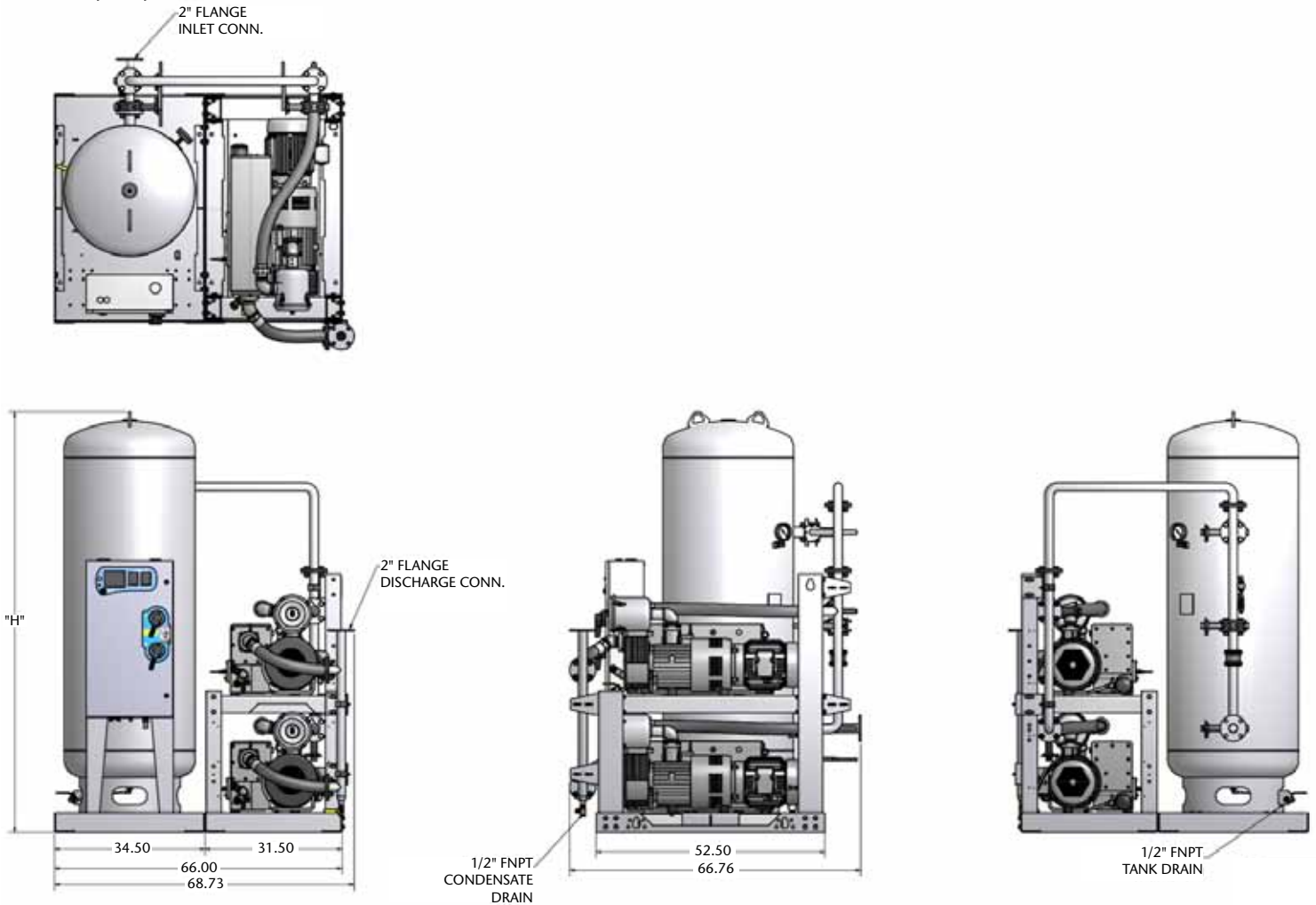

- Notes:**
- Allow 36 inches in front of control panel for maintenance and ventilation, all other sides require 24 inches of clearance.
 - Additional drawings/diagrams available for download at www.beaconmedaes.com.

Vacuum System Specifications¹

System Model No.	HP	Capacity ² @19" Hg (scfm)		System ³ BTU/HR	Receiver (gallons)	Noise ⁴ Level	System FLA			System Weight (lbs.)	Dimensions (in.)
		Pump	System				208V	230V	460V		H
VLS10D-120V-D	10	77	77	20,360	120	81	55.0	53.4	26.2	2,486	81.28
VLS10D-200V-D	10	77	77	20,360	200	81	55.0	53.4	26.2	2,711	84.48
VLS10D-240V-D	10	77	77	20,360	240	81	55.0	53.4	26.2	2,786	96.48

- Notes:**
1. Normal operating conditions at a maximum ambient of 105° F. Consult factory for higher ambient conditions.
 2. All capacities are shown as NFPA system capacities (reserve vacuum pump on standby).
 3. All system BTU/HR are shown with reserve vacuum pump on standby.
 4. All noise levels are shown in dB(A) and reflect reserve pump on standby.
 5. Medical Vacuum System is not to be used in non-medical laboratory applications.